

CURRENT OWNER		TOPO	UTILITIES	STRT / ROAD	LOCATION	CURRENT ASSESSMENT				
WHITE, BRUCE R						Description	Code	Assessed	Assessed	801 FY2024 BARNSTABLE, MA
76 FOXGLOVE ROAD						RESIDNTL	1010	464,900	464,900	
CENTERVILLE MA 02632						RES LAND	1010	152,200	152,200	VISION
SUPPLEMENTAL DATA						Total		617,100	617,100	
Alt Prcl ID Split Zonin RC;RF BID Parcel ResExpt Q #DL 1 LOT 27 #DL 2 GIS ID F_964056_2707331				Plan Ref. 326/29 Land Ct# #SR Life Estate PP STATU Assoc Pid#						

RECORD OF OWNERSHIP		BK-VOL/PAGE	SALE DATE	Q/U	V/I	SALE PRIC	VC	PREVIOUS ASSESSMENTS (HISTORY)								
WHITE, BRUCE R		35448 293	10-27-2022	U	I	1	1F	Year	Code	Assessed	Year	Code	Assessed	Year	Code	Assessed
WHITE, BRUCE R & PATRICIA D		12919 0290	03-31-2000	Q	I	208,500	00	2023	1010	401,500	2022	1010	347,900	2021	1010	286,700
GAGEL, PAULA		7357 0034	11-15-1990	U	I	1	A		1010	138,400		1010	102,500		1010	102,500
GAGEL, PAULA & ANELIA J		4170 0351	07-15-1984	Q	I	85,200	U								1010	1,300
COMMUNITY PROPERTIES INC		3790 0178	07-15-1983	U	V	180,000	N	Total		539,900	Total		450,400	Total		390,500

EXEMPTIONS			OTHER ASSESSMENTS					
Year	Code	Description	Amount	Code	Description	Number	Amount	Comm Int
Total			0.00					

ASSESSING NEIGHBORHOOD			
Nbhd	Nbhd Name	B	Tracing
0105			MARSTM

APPRAISED VALUE SUMMARY	
Appraised Bldg. Value (Card)	399,100
Appraised Xf (B) Value (Bldg)	64,500
Appraised Ob (B) Value (Bldg)	1,300
Appraised Land Value (Bldg)	152,200
Special Land Value	0
Total Appraised Parcel Value	617,100
Valuation Method	C
Total Appraised Parcel Value	617,100

BUILDING PERMIT RECORD						VISIT / CHANGE HISTORY								
Permit Id	Issue Date	Type	Description	Amount	Insp Date	% Comp	Date Comp	Comments	Date	Id	Type	Is	Cd	Purpost/Result
									04-28-2020	LS			FR	Field Review
									07-24-2017	KM	02		03	Cycl Insp Comp
									08-06-2007	PT	02		14	Cyclical Inspection
									07-12-2002	PT	02		01	Meas/Est
									02-15-1985	FR				

LAND LINE VALUATION SECTION																	
B	Use Code	Description	Zone	LA	Land Units	Unit Price	Size Adj	AC Disc	Site Index	Cond.	Nbhd.	Nbhd. Adj	Notes	Location Adjustmen	Adj Unit P	Land Value	
1	1010	Single Fam M-0	SPLI	3	0.350 AC	176,344.00	2.46674	1.0000	5	1.00	0105	1.000		1.0000	434,987.7	152,200	
Total Card Land Units					0.35 AC	Parcel Total Land Area					0.35	Total Land Value					152,200

CONSTRUCTION DETAIL			CONSTRUCTION DETAIL (CONTINUED)		
Element	Cd	Description	Element	Cd	Description
Style	01	Ranch			
Model	01	Residential			
Grade:	C	Average			
Stories	1	1 Story			
Exterior Wall 1					
Exterior Wall 2	25	Vinyl Siding			
Roof Structure	03	Gable/Hip			
Roof Cover	03	Asph/F Gls/Cmp			
Interior Wall 1	05	Drywall			
Interior Wall 2					
Interior Floor 1	14	Carpet			
Interior Floor 2					
Heat Fuel	03	Gas			
Heat Type	05	Hot Water			
AC Type	01	None			
Bedrooms	03	3 Bedrooms			
Full Baths	2				
Half Baths	1				
Extra Fixtures					
Total Rooms	6	6 Rooms			
Bath Style					
Kitchen Style					
Occupancy					
Usrflid 105					
Accessory Apt					
Foundation Alt	01	Poured Conc.			
Rms Prts					
Bath Split	21	2 Full-1 Half			

CONDO DATA			
Parcel Id	C	Owne	0.0
Adjust Type	Code	Description	Factor%
Condo Flr			
Condo Unit			

COST / MARKET VALUATION	
Building Value New	475,175
Year Built	1984
Effective Year Built	1998
Depreciation Code	A
Remodel Rating	
Year Remodeled	
Depreciation %	16
Functional Obsol	0
External Obsol	0
Trend Factor	1
Condition	
Condition %	
Percent Good	84
RCNLD	399,100
Dep % Ovr	
Dep Ovr Comment	
Misc Imp Ovr	
Misc Imp Ovr Comment	
Cost to Cure Ovr	
Cost to Cure Ovr Comment	

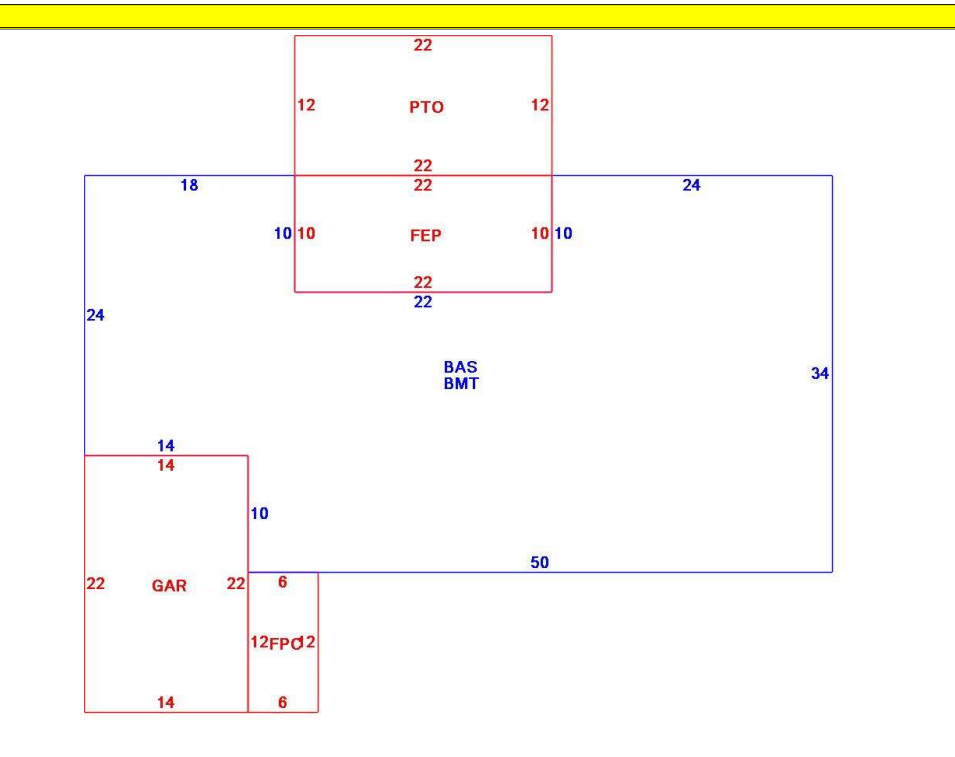

OB - OUTBUILDING & YARD ITEMS(L) / XF - BUILDING EXTRA FEATURES(B)										
Code	Description	L/B	Units	Unit Price	Yr Blt	Cond. Cd	% Gd	Grade	Grade Adj.	Appr. Value
FPL1	Fireplace 1 sto	B	1	5000.00	2000		84		0.00	4,200
PAT1	Patio- Average	L	264	5.89	1999		80		0.00	1,300
FOPC	Open Prch-roo	B	72	55.00	2000		84		0.00	3,100
FEP	Enclosed porc	B	220	70.00	2000		84		0.00	11,200
GAR	Attached Gara	B	308	40.00	2000		84		0.00	11,400
BMT	Basement-Unfi	B	1,816	26.01	2000		84		0.00	34,600

BUILDING SUB-AREA SUMMARY SECTION						
Code	Description	Living Area	Floor Area	Eff Area	Unit Cost	Undeprec Value
BAS	First Floor	1,816	1,816	1,816	261.66	475,175
BMT	Basement Area	0	1,816	0	0.00	0
FEP	Enclosed Porch	0	220	0	0.00	0
FPC	Open Porch Conc. Floor	0	72	0	0.00	0
GAR	Attached Garage	0	308	0	0.00	0
PTO	Patio	0	264	0	0.00	0
Ttl Gross Liv / Lease Area		1,816	4,496	1,816		475,175

