

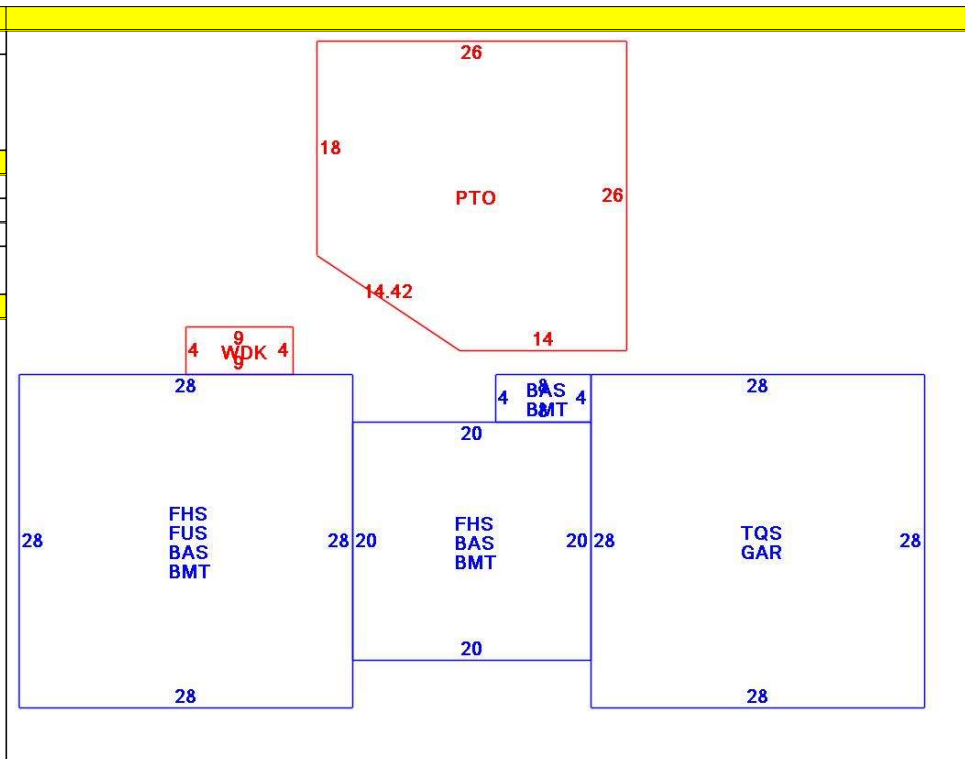

CONSTRUCTION DETAIL			CONSTRUCTION DETAIL (CONTINUED)		
Element	Cd	Description	Element	Cd	Description
Style	03	Colonial			
Model	01	Residential			
Grade:	C	Average			
Stories	2.4				
Exterior Wall 1	14	Wood Shingle			
Exterior Wall 2					
Roof Structure	03	Gable/Hip			
Roof Cover	03	Asph/F Gls/Cmp			
Interior Wall 1	05	Drywall			
Interior Wall 2					
Interior Floor 1	12	Hardwood			
Interior Floor 2	23	Laminate			
Heat Fuel	08	Propane			
Heat Type	04	Hot Air			
AC Type	03	Central			
Bedrooms	04	4 Bedrooms			
Full Baths	3				
Half Baths	0				
Extra Fixtures					
Total Rooms	8				
Bath Style					
Kitchen Style					
Occupancy					
Usrflid 105					
Accessory Apt					
Foundation Alt	01	Poured Conc.			
Rms Prts					
Bath Split	30	3 Full-0 Half			

CONDO DATA				
Parcel Id		C	Owne	0.0
Adjust Type	Code	Description	Factor%	
Condo Flr				
Condo Unit				

COST / MARKET VALUATION		
Building Value New		679,586
Year Built		2005
Effective Year Built		2008
Depreciation Code		A
Remodel Rating		
Year Remodeled		
Depreciation %		9
Functional Obsol		0
External Obsol		0
Trend Factor		1
Condition		
Condition %		
Percent Good		91
RCNLD		618,400
Dep % Ovr		
Dep Ovr Comment		
Misc Imp Ovr		
Misc Imp Ovr Comment		
Cost to Cure Ovr		
Cost to Cure Ovr Comment		



OB - OUTBUILDING & YARD ITEMS(L) / XF - BUILDING EXTRA FEATURES(B)										
Code	Description	L/B	Units	Unit Price	Yr Blt	Cond. Cd	% Gd	Grade	Grade Adj.	Appr. Value
FPL3	Fireplace 2 sto	B	1	7000.00	2010		91		0.00	6,400
GAR	Attached Gara	B	784	40.00	2010		91		0.00	23,300
BMT	Basement-Unfi	B	1,216	26.01	2010		91		0.00	27,500
WDC	Wood Deck w/	L	36	18.00	2020		100		0.00	2,100
PATF	Flagstone Pav	L	628	30.00	2020		100		0.00	17,900
FPIT	Fire Pit	L	1	3010.00	2020		100	C	1.00	3,000

BUILDING SUB-AREA SUMMARY SECTION						
Code	Description	Living Area	Floor Area	Eff Area	Unit Cost	Undeprec Value
BAS	First Floor	1,216	1,216	1,216	219.08	266,401
BMT	Basement Area	0	1,216	0	0.00	0
FHS	Half Story	592	1,184	592	109.54	129,695
FUS	Upper Story	784	784	784	219.08	171,759
GAR	Attached Garage	0	784	0	0.00	0
PTO	Patio	0	628	0	0.00	0
TQS	Three Quarter Story	510	784	510	142.51	111,731
WDK	Wood Deck	0	36	0	0.00	0
Ttl Gross Liv / Lease Area		3,102	6,632	3,102		679,586

