

CONSTRUCTION DETAIL			CONSTRUCTION DETAIL (CONTINUED)		
Element	Cd	Description	Element	Cd	Description
Style	55	Condominium			
Model	05	Res Condo			
Bedrm Func	B+	Custom Plus			
Stories	2	2 Stories			
Occupancy					
Interior Wall 1	05	Drywall			
Interior Wall 2					
Interior Floor 1	14	Carpet			
Interior Floor 2	12	Hardwood			
Heat Fuel	03	Gas			
Heat Type	05	Hot Water			
AC Type	03	Central			
Bedrooms	03	3 Bedrooms			
Full Baths	3	3 Full			
Half Baths	0				
Extra Fixtures					
Total Rooms	7	7 Rooms			
Bath Style	04	Typical for Gr			
Kitchen Style	04	Typical for Gr			
Master Deed L	3688				
Bath Split	30	3 Full-0 Half			
Foundation	01	Poured Conc.			
AC Type Alt					
Sewer Occupan					
CONDO DATA					
Parcel Id	104297	C 0860	Ownr	12.	
	OSTERVILLE COM		B 1	S 1	
Adjust Type	Code	Description	Factor%		
Condo Flr			100		
Condo Unit	MKT0	MKT0	100		
COST / MARKET VALUATION					
Building Value New		1,034,869			
Year Built		1997			
Effective Year Built		2008			
Depreciation Code		A			
Remodel Rating					
Year Remodeled					
Depreciation %		9			
Functional Obsol		0			
External Obsol		0			
Trend Factor		1			
Condition					
Condition %					
Percent Good		91			
Cns Sect Rcnld		941,700			
Dep % Ovr					
Dep Ovr Comment					
Misc Imp Ovr					
Misc Imp Ovr Comment					
Cost to Cure Ovr					
Cost to Cure Ovr Comment					

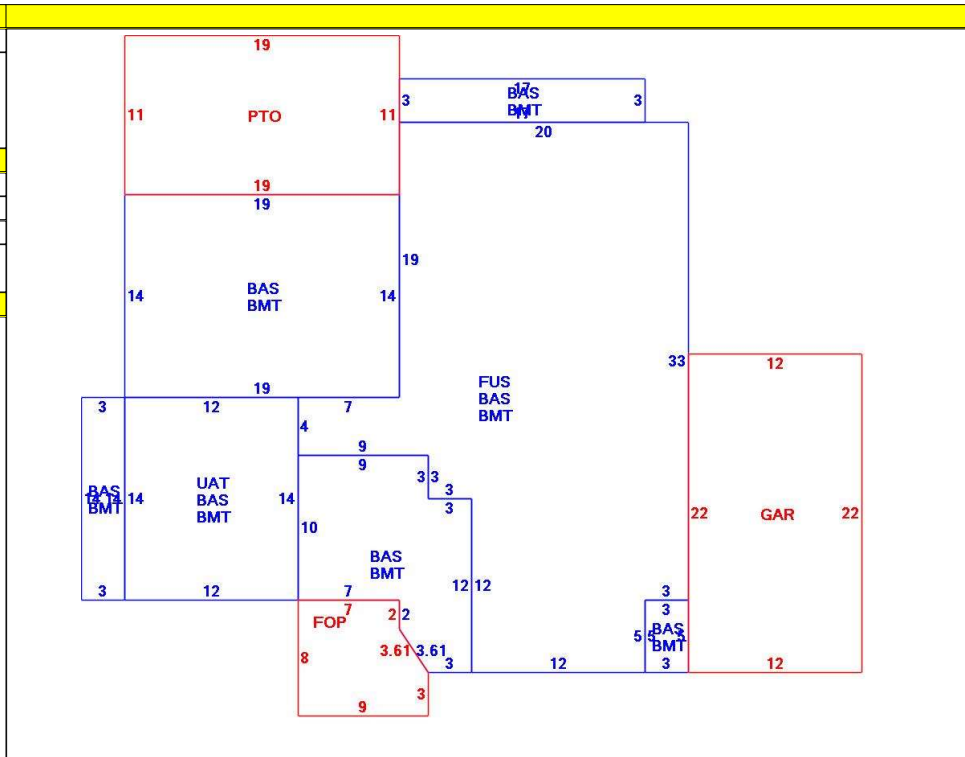

OB - OUTBUILDING & YARD ITEMS(L) / XF - BUILDING EXTRA FEATURES(B)										
Code	Description	L/B	Units	Unit Price	Yr Blt	Cond. Cd	% Gd	Grade	Grade Adj.	Appr. Value
GAR	Attached Gara	B	264	40.00	2010		91		0.00	11,100
BMT	Basement-Unfi	B	1,382	26.01	2010		91		0.00	30,400
FOP	Open Porch-ro	B	65	55.00	2010		91		0.00	3,700
FPL1	Fireplace 1 sto	B	1	5000.00	2010		91		0.00	4,600
PAT2	Patio-Good	L	209	9.94	2005		86		0.00	1,900

BUILDING SUB-AREA SUMMARY SECTION							
Code	Description	Living Area	Floor Area	Eff Area	Unit Cost	Undeprec Value	
BAS	First Floor	1,382	1,382	1,382	491.39	679,102	
BMT	Basement Area	0	1,382	0	0.00	0	
FOP	Open Porch	0	65	0	0.00	0	
FUS	Upper Story	707	707	707	491.39	347,413	
GAR	Attached Garage	0	264	0	0.00	0	
PTO	Patio	0	209	0	0.00	0	
UAT	Attic, Unfinished	0	168	17	49.72	8,354	
Ttl Gross Liv / Lease Area		2,089	4,177	2,106		1,034,869	

