

CURRENT OWNER		TOPO		UTILITIES		STRT / ROAD		LOCATION		CURRENT ASSESSMENT			
BENTLEY, JOHN & CHRISTINA		2	Above Street	2	Public Water	1	Paved	1	Marginal View	Description	Code	Assessed	Assessed
		4		4	Gas					RESIDNTL	1010	474,700	474,700
		6		6	Septic					RES LAND	1010	247,700	247,700
SUPPLEMENTAL DATA													
150 ABBEY GATE		Alt Prcl ID				Plan Ref. 271/56				Total 722,400 722,400			
COTUIT MA 02635		Split Zonin				Land Ct#							
		#DL 1 LOTS 16 & 17				#SR							
		#DL 2				Life Estate							
		GIS ID F_943904_2689858				PP STATU							
		Assoc Pid#											

801
 FY2024
 BARNSTABLE, MA

VISION

RECORD OF OWNERSHIP		BK-VOL/PAGE		SALE DATE		Q/U		V/I		SALE PRIC		VC		PREVIOUS ASSESSMENTS (HISTORY)					
BENTLEY, JOHN & CHRISTINA		34999	302	03-25-2022		Q	I	842,000		00	Year Code Assessed Year Code Assessed V Year Code Assessed								
LONABOCKER, LYNN & THOMAS TRS		21681	0107	01-08-2007		U	I	1		1A	2023	1010	372,600	2022	1010	349,000	2021	1010	297,800
LONABOCKER, LYNN & THOMAS		16646	0017	03-28-2003		Q	I	450,000		00		1010	225,200		1010	155,100		1010	157,600
MOGAVERO, SUSAN		15090	0039	04-26-2002		U	I	1		1								1010	5,600
MOGAVERO, LEO G TR		12573	0189	09-30-1999		Q	I	297,000		00	Total 597,800 Total 504,100 Total 461,000								

EXEMPTIONS			OTHER ASSESSMENTS					
Year	Code	Description	Amount	Code	Description	Number	Amount	Comm Int
Total			0.00					

This signature acknowledges a visit by a Data Collector or Assessor

ASSESSING NEIGHBORHOOD				
Nbhd	Nbhd Name	B	Tracing	Batch
0107				COTUIT

APPRAISED VALUE SUMMARY	
Appraised Bldg. Value (Card)	417,500
Appraised Xf (B) Value (Bldg)	51,600
Appraised Ob (B) Value (Bldg)	5,600
Appraised Land Value (Bldg)	247,700
Special Land Value	0
Total Appraised Parcel Value	722,400
Valuation Method	C
Total Appraised Parcel Value	722,400

NOTES									

LAND LINE VALUATION SECTION

B	Use Code	Description	Zone	LA	Land Units	Unit Price	Size Adj	AC Disc	Site Index	Cond.	Nbhd.	Nbhd. Adj	Notes	Location Adjustmen	Adj Unit P	Land Value
1	1010	Single Fam M-0	RF	2	1.000	AC 176,344.00	1.00000	1.0000	5	1.00	0107	1.400		1.0000	246,881.6	246,900
1	1010	Single Fam M-0	RF	2	0.040	AC 14,250.00	1.00000	1.0000	0	1.00	0107	1.400		1.0000	19,950	800

CONSTRUCTION DETAIL			CONSTRUCTION DETAIL (CONTINUED)		
Element	Cd	Description	Element	Cd	Description
Style	07	Modern/Contemp			
Model	01	Residential			
Grade:	C+	Average Plus			
Stories	1	1 Story			
Exterior Wall 1	14	Wood Shingle			
Exterior Wall 2	06	Vertical Sidin			
RooF Structure	03	Gable/Hip			
RooF Cover	03	Asph/F Gls/Cmp			
Interior Wall 1	05	Drywall			
Interior Wall 2					
Interior Floor 1	12	Hardwood			
Interior Floor 2					
Heat Fuel	03	Gas			
Heat Type	04	Hot Air			
AC Type	03	Central			
Bedrooms	04	4 Bedrooms			
Full Baths	3				
Half Baths	0				
Extra Fixtures					
Total Rooms	7	7 Rooms			
Bath Style					
Kitchen Style					
Occupancy					
UsrflD 105					
Accessory Apt					
Foundation Alt	01	Poured Conc.			
Rms Prts					
Bath Split	30	3 Full-0 Half			

CONDO DATA			
Parcel Id		C	Ownr 0.0
		B	S
Adjust Type	Code	Description	Factor%
Condo Flr			
Condo Unit			

COST / MARKET VALUATION	
Building Value New	502,983
Year Built	1982
Effective Year Built	1997
Depreciation Code	A
Remodel Rating	
Year Remodeled	
Depreciation %	17
Functional Obsol	0
External Obsol	0
Trend Factor	1
Condition	
Condition %	
Percent Good	83
RCNLD	417,500
Dep % Ovr	
Dep Ovr Comment	
Misc Imp Ovr	
Misc Imp Ovr Comment	
Cost to Cure Ovr	
Cost to Cure Ovr Comment	

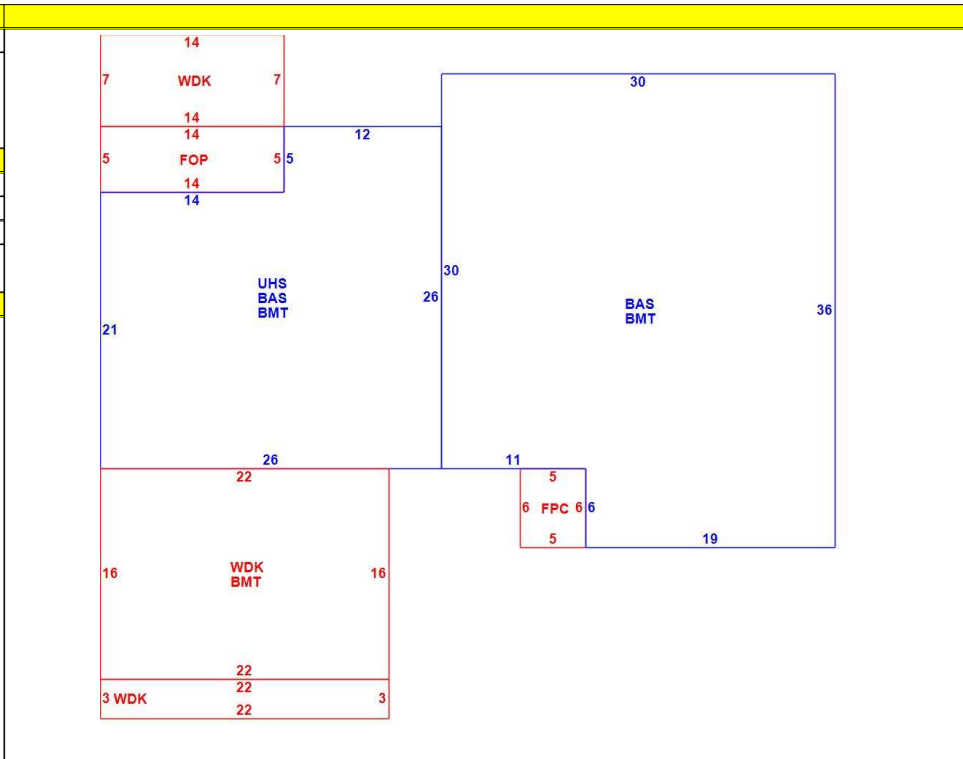

OB - OUTBUILDING & YARD ITEMS(L) / XF - BUILDING EXTRA FEATURES(B)										
Code	Description	L/B	Units	Unit Price	Yr Blt	Cond. Cd	% Gd	Grade	Grade Adj.	Appr. Value
BRR	Bsmt Rec Rm-	B	336	8.05	1999		83		0.00	2,200
FPLG	Gas Fireplace-	B	1	2500.00	1999		83		0.00	2,100
WDC	Wood Decking	L	516	20.00	1998		58		0.00	5,600
FOP	Open Porch-ro	B	70	55.00	1999		83		0.00	3,600
BMT	Basement-Unfi	B	1,972	26.01	1999		83		0.00	36,700
FOPC	Open Prch-roo	B	30	55.00	1999		83		0.00	1,600
BGR2	2 Stall Bmt Ga	B	2	3244.00	1999		83		0.00	5,400

BUILDING SUB-AREA SUMMARY SECTION						
Code	Description	Living Area	Floor Area	Eff Area	Unit Cost	Undeprec Value
BAS	First Floor	1,620	1,620	1,620	279.13	452,183
BMT	Basement Area	0	1,972	0	0.00	0
FOP	Open Porch	0	70	0	0.00	0
FPC	Open Porch Conc. Floor	0	30	0	0.00	0
UHS	Half Story, Unfinished	0	606	182	83.83	50,801
WDK	Wood Deck	0	516	0	0.00	0
Ttl Gross Liv / Lease Area		1,620	4,814	1,802		502,984

