

| CURRENT OWNER  |  | TOPO | UTILITIES | STRT / ROAD | LOCATION   | CURRENT ASSESSMENT |       |           |           |                                 |
|--|--|------|-----------|-------------|--|--------------------|-------|-----------|-----------|---------------------------------|
| JOSEPH, STEVEN G   |  |      |           |             |  | Description        | Code  | Assessed  | Assessed  | 801<br>FY2024<br>BARNSTABLE, MA |
| 10 GUINEVERE CIRCLE  |  |      |           |             |  | RESIDNTL           | 1010  | 1,050,500 | 1,050,500 |                                 |
| SHREWSBURY MA 01545  |  |      |           |             |  | RES LAND           | 1010  | 556,300   | 556,300   |                                 |
| SUPPLEMENTAL DATA  |  |      |           |             |  |                    |       |           |           |                                 |
| Alt Prcl ID<br>Split Zonin<br>BID Parcel<br>ResExpt Q NO APP:<br>#DL 1 LOT D-1<br>#DL 2<br>GIS ID F_953849_2710196 |  |      |           |             | Plan Ref. 567/50<br>Land Ct#<br>#SR<br>Life Estate<br>PP STATU<br>Assoc Pid# |                    | Total |           | 1,606,800 | 1,606,800                       |

**VISION**

| RECORD OF OWNERSHIP              |  | BK-VOL/PAGE | SALE DATE  | Q/U | V/I | SALE PRIC | VC | PREVIOUS ASSESSMENTS (HISTORY) |      |           |       |      |           |       |      |          |
|----------------------------------|--|-------------|------------|-----|-----|-----------|----|--------------------------------|------|-----------|-------|------|-----------|-------|------|----------|
| JOSEPH, STEVEN G                 |  | 32634 0077  | 01-21-2020 | Q   | I   | 1,300,000 | 00 | Year                           | Code | Assessed  | Year  | Code | Assessed  | Year  | Code | Assessed |
| HUNTLEY, CRAIG W & ELLIS, BONNIE |  | 26142 0051  | 03-08-2012 | U   | I   | 345,000   | 1P | 2023                           | 1010 | 936,400   | 2022  | 1010 | 792,800   | 2021  | 1010 | 565,900  |
| PETERS, PAMELA L                 |  | 15090 0308  | 04-26-2002 | U   | V   | 195,000   | 1L |                                | 1010 | 657,000   |       | 1010 | 374,500   |       | 1010 | 399,400  |
| WMC MORTGAGE CORP                |  | 14577 0029  | 12-14-2001 | U   | I   | 480,000   | 1L | Total                          |      | 1,593,400 | Total |      | 1,167,300 | Total |      | 982,500  |

| EXEMPTIONS |      |                          |        | OTHER ASSESSMENTS |             |        |        | This signature acknowledges a visit by a Data Collector or Assessor |  |  |  |  |  |  |  |  |
|------------|------|--------------------------|--------|-------------------|-------------|--------|--------|---|--|--|--|--|--|--|--|--|
| Year       | Code | Description              | Amount | Code              | Description | Number | Amount | Comm Int  |  |  |  |  |  |  |  |  |
| 2022       | N5C  | NO RESIDENTIAL EXEMPTION | 0.00   |                   |             |        |        |   |  |  |  |  |  |  |  |  |
| Total      |      |                          | 0.00   |                   |             |        |        |   |  |  |  |  |  |  |  |  |

| ASSESSING NEIGHBORHOOD |           |   |         | APPRAISED VALUE SUMMARY |  |  |  |                               |  |  |  |           |
|------------------------|-----------|---|---------|-------------------------|--|--|--|-------------------------------|--|--|--|-----------|
| Nbhd                   | Nbhd Name | B | Tracing | Batch                   |  |  |  |                               |  |  |  |           |
| 0111                   |           |   | MARSTM  |                         |  |  |  |                               |  |  |  |           |
| NOTES                  |           |   |         |                         |  |  |  | Appraised Bldg. Value (Card)  |  |  |  | 901,800   |
|                        |           |   |         |                         |  |  |  | Appraised Xf (B) Value (Bldg) |  |  |  | 131,500   |
|                        |           |   |         |                         |  |  |  | Appraised Ob (B) Value (Bldg) |  |  |  | 17,200    |
|                        |           |   |         |                         |  |  |  | Appraised Land Value (Bldg)   |  |  |  | 556,300   |
|                        |           |   |         |                         |  |  |  | Special Land Value            |  |  |  | 0         |
|                        |           |   |         |                         |  |  |  | Total Appraised Parcel Value  |  |  |  | 1,606,800 |
|                        |           |   |         |                         |  |  |  | Valuation Method              |  |  |  | C         |
|                        |           |   |         |                         |  |  |  | Total Appraised Parcel Value  |  |  |  | 1,606,800 |

| BUILDING PERMIT RECORD |            |      |                  |         |            |        |            |                                |  | VISIT / CHANGE HISTORY |    |      |    |    |                       |
|------------------------|------------|------|------------------|---------|------------|--------|------------|--------------------------------|--|------------------------|----|------|----|----|-----------------------|
| Permit Id              | Issue Date | Type | Description      | Amount  | Insp Date  | % Comp | Date Comp  | Comments                       |  | Date                   | Id | Type | Is | Cd | Purpost/Result        |
| BLDR-21-16             | 02-03-2021 | 880  | Alt-Int work-Res | 17,000  |            | 0      |            | Finishing 14'x20' room in base |  | 07-08-2020             | CK | 03   |    | 16 | In Office Review      |
| 201506160              | 10-30-2015 | PV   | Solar PV Syste   | 23,400  | 03-18-2016 | 100    | 06-30-2016 | ROOF TOP PV SOLAR INSTA        |  | 05-12-2020             | LS |      |    | FR | Field Review          |
| 201501162              | 03-23-2015 | DK   | Dock             | 7,700   | 07-20-2015 | 100    | 06-30-2015 | TO INSTALL 168 SQ. FT. PRE     |  | 03-23-2016             | SR | 02   |    | 02 | Bldg Permit Completed |
| 201204516              | 08-23-2012 | DW   | Dwelling         | 350,000 | 05-14-2013 | 100    | 06-30-2013 | NW DW-3BDRM 3.5BTHCW A         |  | 07-27-2015             | SR | 02   |    | 02 | Bldg Permit Completed |
|                        |            |      |                  |         |            |        |            |                                |  | 05-23-2013             | RB | 03   |    | 02 | Bldg Permit Completed |
|                        |            |      |                  |         |            |        |            |                                |  | 03-12-2012             | DR | 03   |    | 16 | In Office Review      |
|                        |            |      |                  |         |            |        |            |                                |  | 05-10-2006             | GB |      |    | 15 | Abatement Review      |

| LAND LINE VALUATION SECTION |          |                |      |    |            |            |                        |         |            |       |       |           |                  |                    |            |            |
|-----------------------------|----------|----------------|------|----|------------|------------|------------------------|---------|------------|-------|-------|-----------|------------------|--------------------|------------|------------|
| B                           | Use Code | Description    | Zone | LA | Land Units | Unit Price | Size Adj               | AC Disc | Site Index | Cond. | Nbhd. | Nbhd. Adj | Notes            | Location Adjustmen | Adj Unit P | Land Value |
| 1                           | 1010     | Single Fam M-0 | RF   | 3  | 1.000 AC   | 176,344.00 | 1.00000                | 1.0000  | 5          | 1.00  | 0111  | 3.050     | MYSTIC LAKE      | 1.0000             | 537,849.2  | 537,800    |
| 1                           | 1010     | Single Fam M-0 | RF   | 3  | 0.410 AC   | 14,250.00  | 1.00000                | 1.0000  | 0          | 1.00  | 0111  | 3.050     |                  | 1.0000             | 43,462.5   | 17,800     |
| 1                           | 1010     | Single Fam M-0 | RF   | 3  | 0.300 AC   | 2,375.00   | 1.00000                | 1.0000  | 0          | 1.00  | WTLD  | 1.000     | WETLAND          | 1.0000             | 2,375      | 700        |
| Total Card Land Units       |          |                |      |    | 1.71       | AC         | Parcel Total Land Area |         |            |       |       | 1.71      | Total Land Value |                    |            | 556,300    |

| CONSTRUCTION DETAIL |     |                | CONSTRUCTION DETAIL (CONTINUED) |    |             |
|---------------------|-----|----------------|---------------------------------|----|-------------|
| Element             | Cd  | Description    | Element                         | Cd | Description |
| Style               | 04  | Cape Cod       |                                 |    |             |
| Model               | 01  | Residential    |                                 |    |             |
| Grade:              | B+  | Custom Plus    |                                 |    |             |
| Stories             | 1.5 | 1 1/2 Stories  |                                 |    |             |
| Exterior Wall 1     | 30  | Cement Siding  |                                 |    |             |
| Exterior Wall 2     | 21  | Stone/Masonry  |                                 |    |             |
| RooF Structure      | 03  | Gable/Hip      |                                 |    |             |
| RooF Cover          | 03  | Asph/F Gls/Cmp |                                 |    |             |
| Interior Wall 1     | 05  | Drywall        |                                 |    |             |
| Interior Wall 2     |     |                |                                 |    |             |
| Interior Floor 1    | 12  | Hardwood       |                                 |    |             |
| Interior Floor 2    | 23  | Laminate       |                                 |    |             |
| Heat Fuel           | 03  | Gas            |                                 |    |             |
| Heat Type           | 04  | Hot Air        |                                 |    |             |
| AC Type             | 03  | Central        |                                 |    |             |
| Bedrooms            | 03  | 3 Bedrooms     |                                 |    |             |
| Full Baths          | 3   |                |                                 |    |             |
| Half Baths          | 1   |                |                                 |    |             |
| Extra Fixtures      |     |                |                                 |    |             |
| Total Rooms         | 8   |                |                                 |    |             |
| Bath Style          |     |                |                                 |    |             |
| Kitchen Style       |     |                |                                 |    |             |
| Occupancy           |     |                |                                 |    |             |
| Usrflid 105         |     |                |                                 |    |             |
| Accessory Apt       |     |                |                                 |    |             |
| Foundation Alt      | 01  | Poured Conc.   |                                 |    |             |
| Rms Prts            |     |                |                                 |    |             |
| Bath Split          | 31  | 3 Full-1 Half  |                                 |    |             |

| CONDO DATA  |      |             |         |     |
|-------------|------|-------------|---------|-----|
| Parcel Id   |      | C           | Owne    | 0.0 |
| Adjust Type | Code | Description | Factor% |     |
| Condo Flr   |      |             |         |     |
| Condo Unit  |      |             |         |     |

| COST / MARKET VALUATION  |         |         |
|--------------------------|---------|---------|
| Building Value New       |         | 901,792 |
| Year Built               | 2012    |         |
| Effective Year Built     | 2019    |         |
| Depreciation Code        | VG      |         |
| Remodel Rating           |         |         |
| Year Remodeled           |         |         |
| Depreciation %           | 0       |         |
| Functional Obsol         | 0       |         |
| External Obsol           | 0       |         |
| Trend Factor             | 1       |         |
| Condition                |         |         |
| Condition %              |         |         |
| Percent Good             | 100     |         |
| RCNLD                    | 901,800 |         |
| Dep % Ovr                |         |         |
| Dep Ovr Comment          |         |         |
| Misc Imp Ovr             |         |         |
| Misc Imp Ovr Comment     |         |         |
| Cost to Cure Ovr         |         |         |
| Cost to Cure Ovr Comment |         |         |

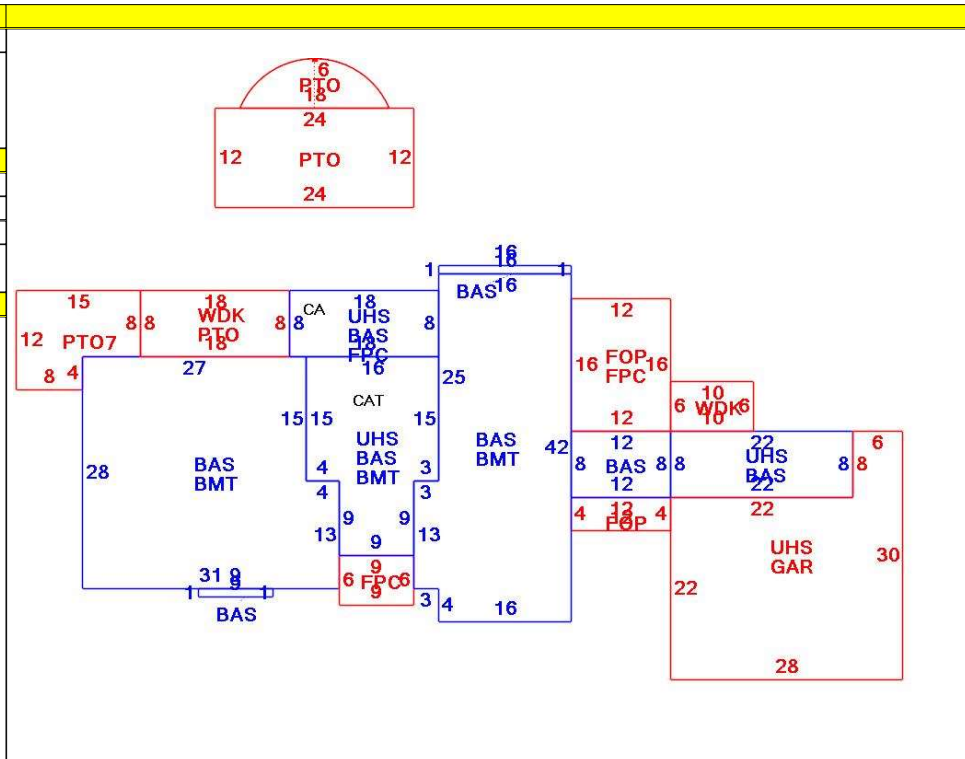

**OB - OUTBUILDING & YARD ITEMS(L) / XF - BUILDING EXTRA FEATURES(B)**

| Code | Description    | L/B | Units | Unit Price | Yr Blt | Cond. Cd | % Gd | Grade | Grade Adj. | Appr. Value |
|------|----------------|-----|-------|------------|--------|----------|------|-------|------------|-------------|
| FPLG | Gas Fireplace- | B   | 1     | 2500.00    | 2014   |          | 100  |       | 0.00       | 2,500       |
| BFA1 | Bsmt Fin-Goo   | B   | 1,236 | 32.56      | 2014   |          | 100  |       | 0.00       | 40,200      |
| BMT  | Basement-Unfi  | B   | 1,840 | 26.01      | 2014   |          | 100  |       | 0.00       | 41,700      |
| FOPC | Open Prch-roo  | B   | 198   | 55.00      | 2014   |          | 100  |       | 0.00       | 7,700       |
| FOP  | Open Porch-ro  | B   | 432   | 55.00      | 2014   |          | 100  |       | 0.00       | 16,800      |
| GAR  | Attached Gara  | B   | 664   | 40.00      | 2014   |          | 100  |       | 0.00       | 22,600      |
| WDC  | Wood Decking   | L   | 204   | 20.00      | 2012   |          | 86   |       | 0.00       | 4,100       |
| DKPL | Pond Dock-Lig  | L   | 1     | 4200.00    | 2015   |          | 100  |       | 0.00       | 4,200       |
| PAT2 | Patio-Good     | L   | 662   | 9.94       | 2015   |          | 96   |       | 0.00       | 6,000       |
| FPIT | Fire Pit       | L   | 1     | 3010.00    | 2015   |          | 96   | C     | 1.00       | 2,900       |

**BUILDING SUB-AREA SUMMARY SECTION**

| Code                       | Description            | Living Area | Floor Area | Eff Area | Unit Cost | Undeprec Value |
|----------------------------|------------------------|-------------|------------|----------|-----------|----------------|
| BAS                        | First Floor            | 2,281       | 2,281      | 2,281    | 337.37    | 769,543        |
| BMT                        | Basement Area          | 0           | 1,840      | 0        | 0.00      | 0              |
| FOP                        | Open Porch             | 0           | 240        | 0        | 0.00      | 0              |
| FPC                        | Open Porch Conc. Floor | 0           | 390        | 0        | 0.00      | 0              |
| GAR                        | Attached Garage        | 0           | 664        | 0        | 0.00      | 0              |
| PTO                        | Patio                  | 0           | 662        | 0        | 0.00      | 0              |
| UHS                        | Half Story, Unfinished | 0           | 1,305      | 392      | 101.34    | 132,249        |
| WDK                        | Wood Deck              | 0           | 204        | 0        | 0.00      | 0              |
| Ttl Gross Liv / Lease Area |                        | 2,281       | 7,586      | 2,673    |           | 901,792        |



| CURRENT OWNER  |  | TOPO | UTILITIES | STRT / ROAD  | LOCATION | CURRENT ASSESSMENT        |      |           |           |                                 |
|--|--|------|-----------|--|----------|---------------------------|------|-----------|-----------|---------------------------------|
| JOSEPH, STEVEN G   |  |      |           |  |          | Description               | Code | Assessed  | Assessed  | 801<br>FY2024<br>BARNSTABLE, MA |
| 10 GUINEVERE CIRCLE  |  |      |           |  |          | RESIDNTL                  | 1010 | 1,050,500 | 1,050,500 |                                 |
| SHREWSBURY MA 01545  |  |      |           |  |          | RES LAND                  | 1010 | 556,300   | 556,300   |                                 |
| SUPPLEMENTAL DATA  |  |      |           |  |          |                           |      |           |           |                                 |
| Alt Prcl ID<br>Split Zonin<br>BID Parcel<br>ResExpt Q NO APP:<br>#DL 1 LOT D-1<br>#DL 2<br>GIS ID F_953849_2710196 |  |      |           | Plan Ref. 567/50<br>Land Ct#<br>#SR<br>Life Estate<br>PP STATU<br>Assoc Pid# |          | Total 1,606,800 1,606,800 |      |           |           |                                 |

**VISION**

| RECORD OF OWNERSHIP |  | BK-VOL/PAGE | SALE DATE | Q/U | V/I | SALE PRIC | VC | PREVIOUS ASSESSMENTS (HISTORY) |      |           |       |      |           |       |      |          |
|---------------------|--|-------------|-----------|-----|-----|-----------|----|--------------------------------|------|-----------|-------|------|-----------|-------|------|----------|
|                     |  |             |           |     |     |           |    | Year                           | Code | Assessed  | Year  | Code | Assessed  | Year  | Code | Assessed |
|                     |  |             |           |     |     |           |    | 2023                           | 1010 | 936,400   | 2022  | 1010 | 792,800   | 2021  | 1010 | 565,900  |
|                     |  |             |           |     |     |           |    |                                | 1010 | 657,000   |       | 1010 | 374,500   |       | 1010 | 399,400  |
|                     |  |             |           |     |     |           |    |                                |      |           |       |      |           |       | 1010 | 17,200   |
|                     |  |             |           |     |     |           |    | Total                          |      | 1,593,400 | Total |      | 1,167,300 | Total |      | 982,500  |

| EXEMPTIONS             |           |             | OTHER ASSESSMENTS |      |             |        |        | APPRAISED VALUE SUMMARY                |   |  |  |  |  |  |  |  |
|------------------------|-----------|-------------|-------------------|------|-------------|--------|--------|--|---|--|--|--|--|--|--|--|
| Year                   | Code      | Description | Amount            | Code | Description | Number | Amount | Comm Int                               | This signature acknowledges a visit by a Data Collector or Assessor |  |  |  |  |  |  |  |
|                        |           |             |                   |      |             |        |        |  | Appraised Bldg. Value (Card) 901,800                                |  |  |  |  |  |  |  |
| Total                  |           |             |                   |      |             |        |        |  | Appraised Xf (B) Value (Bldg) 131,500                               |  |  |  |  |  |  |  |
| ASSESSING NEIGHBORHOOD |           |             |                   |      |             |        |        | Appraised Ob (B) Value (Bldg) 17,200   |   |  |  |  |  |  |  |  |
| Nbhd                   | Nbhd Name |             | B                 |      | Tracing     |        | Batch  |  | Appraised Land Value (Bldg) 556,300                                 |  |  |  |  |  |  |  |
| 0111                   |           |             |                   |      |             |        | MARSTM |  | Special Land Value 0  |  |  |  |  |  |  |  |
| NOTES                  |           |             |                   |      |             |        |        | Total Appraised Parcel Value 1,606,800 |   |  |  |  |  |  |  |  |
|                        |           |             |                   |      |             |        |        | Valuation Method C                     |   |  |  |  |  |  |  |  |
|                        |           |             |                   |      |             |        |        | Total Appraised Parcel Value 1,606,800 |   |  |  |  |  |  |  |  |

| BUILDING PERMIT RECORD |            |      |             |        |           |        |           |          |  | VISIT / CHANGE HISTORY |    |      |    |    |                |
|------------------------|------------|------|-------------|--------|-----------|--------|-----------|----------|--|------------------------|----|------|----|----|----------------|
| Permit Id              | Issue Date | Type | Description | Amount | Insp Date | % Comp | Date Comp | Comments |  | Date                   | Id | Type | Is | Cd | Purpost/Result |
|                        |            |      |             |        |           |        |           |          |  |                        |    |      |    |    |                |

| LAND LINE VALUATION SECTION |          |             |      |    |                        |            |          |         |            |                  |       |           |       |  |                    |            |            |
|-----------------------------|----------|-------------|------|----|------------------------|------------|----------|---------|------------|------------------|-------|-----------|-------|--|--------------------|------------|------------|
| B                           | Use Code | Description | Zone | LA | Land Units             | Unit Price | Size Adj | AC Disc | Site Index | Cond.            | Nbhd. | Nbhd. Adj | Notes |  | Location Adjustmen | Adj Unit P | Land Value |
|                             |          |             |      |    |                        |            |          |         |            |                  |       |           |       |  |                    |            |            |
| Total Card Land Units       |          |             |      |    | Parcel Total Land Area |            |          |         |            | Total Land Value |       |           |       |  |                    |            |            |

