

CURRENT OWNER		TOPO	UTILITIES	STRT / ROAD	LOCATION	CURRENT ASSESSMENT			
HELMAN, STEPHEN & SUSAN GLAS 8 CURRYCOMB CIRCLE WEST BARNSTA MA 02668		1 Level	6 Septic	1 Paved		Description	Code	Assessed	Assessed
			4 Gas			RESIDNTL	1010	529,100	529,100
			2 Public Water			RES LAND	1010	177,300	177,300
SUPPLEMENTAL DATA						Total			
Alt Prcl ID		Split Zonin		Plan Ref. 421/1					
BID Parcel		ResExpt Q YES:		Land Ct#					
#DL 1 LOTS 17 & 33		#DL 2		Life Estate					
GIS ID F_964067_2712855		Assoc Pid#							

801
 FY2024
 BARNSTABLE, MA

VISION

RECORD OF OWNERSHIP		BK-VOL/PAGE	SALE DATE	Q/U	V/I	SALE PRIC	VC	PREVIOUS ASSESSMENTS (HISTORY)							
HELMAN, STEPHEN & SUSAN GLASS		33718 310	01-25-2021	U	I	1	1F	Year	Code	Assessed	Year	Code	Assessed		
HELMAN, STEPHEN & SUSAN G		8446 0288	02-15-1993	Q	I	165,000	U	2023	1010	470,400	2022	1010	401,200		
THORNTON, DAVID S & LESLIE		5952 0194	09-15-1987	Q	I	190,000	U		1010	175,200	2021	1010	124,600		
									1010			1010	17,300		
Total										645,600		Total	525,800	Total	472,200

EXEMPTIONS				OTHER ASSESSMENTS			
Year	Code	Description	Amount	Code	Description	Number	Amount
2023	5C	RESIDENTIAL EXEMPTION	0.00				
Total			0.00				

This signature acknowledges a visit by a Data Collector or Assessor

ASSESSING NEIGHBORHOOD			
Nbhd	Nbhd Name	B	Tracing
0106			WBARNs

APPRAISED VALUE SUMMARY	
Appraised Bldg. Value (Card)	463,800
Appraised Xf (B) Value (Bldg)	48,000
Appraised Ob (B) Value (Bldg)	17,300
Appraised Land Value (Bldg)	177,300
Special Land Value	0
Total Appraised Parcel Value	706,400
Valuation Method	C
Total Appraised Parcel Value	706,400

NOTES							

BUILDING PERMIT RECORD								VISIT / CHANGE HISTORY							
Permit Id	Issue Date	Type	Description	Amount	Insp Date	% Comp	Date Comp	Comments	Date	Id	Type	Is	Cd	Purpost/Result	
BLDR-23-50	04-06-2023	880	Alt-Int work-Res	15,025		100		Demo drywall tub and replace	07-15-2022	EG	03		16	In Office Review	
EXPR-21-1	08-19-2021	835	Sid/Wind/Roof/	2,000		100		insulation and air sealing work	04-27-2020	LS			FR	Field Review	
201305002	07-26-2013	GN	Generator	0	11-25-2014	100	06-30-2015	GENERATOR	05-14-2018	MS	03		16	In Office Review	
B29208	04-01-1986	DW	Dwelling	0	01-15-1987	100	12-31-1987	WB 11/2 S	01-12-2018	SR	02		03	Cycl Insp Comp	
									11-25-2014	RB	03		16	In Office Review	
									08-11-2014	JR	03		16	In Office Review	
									01-07-2008	PT	02		14	Cyclical Inspection	

LAND LINE VALUATION SECTION																
B	Use Code	Description	Zone	LA	Land Units	Unit Price	Size Adj	AC Disc	Site Index	Cond.	Nbhd.	Nbhd. Adj	Notes	Location Adjustmen	Adj Unit P	Land Value
1	1010	Single Fam M-0	RF	5	0.410 AC	176,344.00	2.13291	1.0000	5	1.00	0106	1.150			1.0000	432,554.2
Total Card Land Units					0.41	AC	Parcel Total Land Area					0.41	Total Land Value			177,300

CONSTRUCTION DETAIL			CONSTRUCTION DETAIL (CONTINUED)		
Element	Cd	Description	Element	Cd	Description
Style	04	Cape Cod			
Model	01	Residential			
Grade:	C+	Average Plus			
Stories	1.75	1 3/4 Stories			
Exterior Wall 1	14	Wood Shingle			
Exterior Wall 2	25	Vinyl Siding			
Roof Structure	03	Gable/Hip			
Roof Cover	03	Asph/F Gls/Cmp			
Interior Wall 1	05	Drywall			
Interior Wall 2					
Interior Floor 1	12	Hardwood			
Interior Floor 2	14	Carpet			
Heat Fuel	03	Gas			
Heat Type	04	Hot Air			
AC Type	03	Central			
Bedrooms	03	3 Bedrooms			
Full Baths	3				
Half Baths	0				
Extra Fixtures					
Total Rooms	6	6 Rooms			
Bath Style					
Kitchen Style					
Occupancy					
Usrflid 105					
Accessory Apt					
Foundation Alt	01	Poured Conc.			
Rms Prts					
Bath Split	30	3 Full-0 Half			

CONDO DATA				
Parcel Id		C		Owne 0.0
			B	S
Adjust Type	Code	Description	Factor%	
Condo Flr				
Condo Unit				

COST / MARKET VALUATION	
Building Value New	552,184
Year Built	1986
Effective Year Built	1999
Depreciation Code	A
Remodel Rating	
Year Remodeled	
Depreciation %	16
Functional Obsol	0
External Obsol	0
Trend Factor	1
Condition	
Condition %	
Percent Good	84
RCNLD	463,800
Dep % Ovr	
Dep Ovr Comment	
Misc Imp Ovr	
Misc Imp Ovr Comment	
Cost to Cure Ovr	
Cost to Cure Ovr Comment	

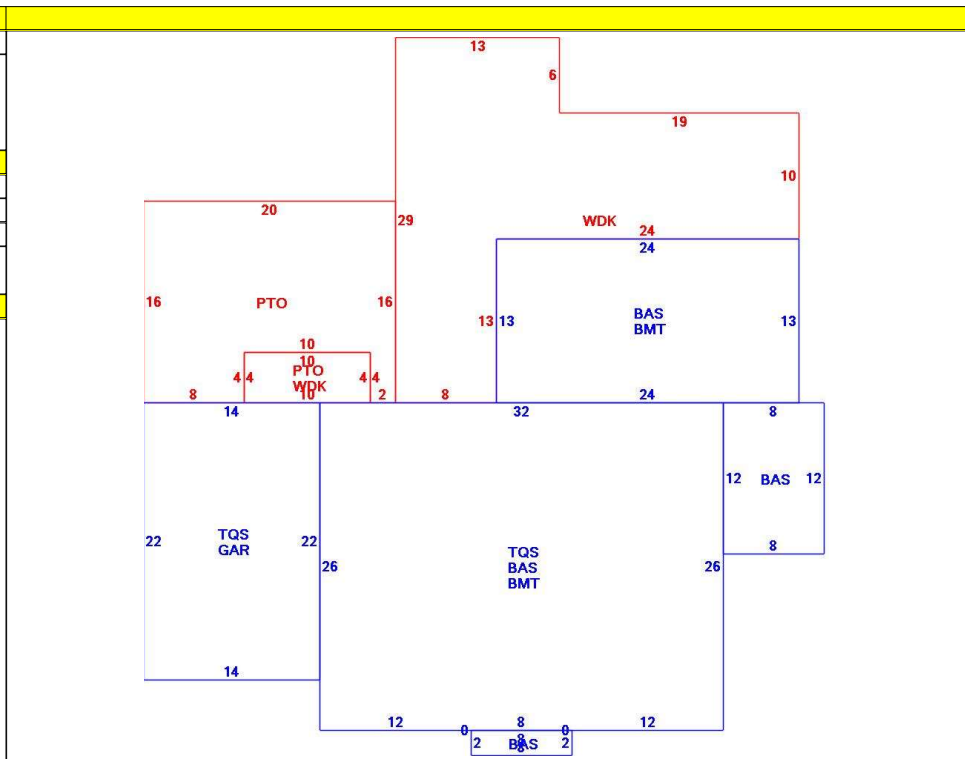

OB - OUTBUILDING & YARD ITEMS(L) / XF - BUILDING EXTRA FEATURES(B)										
Code	Description	L/B	Units	Unit Price	Yr Blt	Cond. Cd	% Gd	Grade	Grade Adj.	Appr. Value
FPL2	Fireplace 1.5 s	B	2	6000.00	2001		84		0.00	10,100
WDC	Deck comp w	L	542	28.00	1999		60		0.00	8,500
PATC	Conc Pavers	L	320	15.46	1999		80		0.00	3,900
GAR	Attached Gara	B	308	40.00	2001		84		0.00	11,400
BMT	Basement-Unfi	B	1,144	26.01	2001		84		0.00	24,400
GEN	Emergency Ge	L	1	5550.00	2013		88		0.00	4,900
FPLG	Gas Fireplace-	B	1	2500.00	2001		84		0.00	2,100

BUILDING SUB-AREA SUMMARY SECTION						
Code	Description	Living Area	Floor Area	Eff Area	Unit Cost	Undeprec Value
BAS	First Floor	1,256	1,256	1,256	276.51	347,293
BMT	Basement Area	0	1,144	0	0.00	0
GAR	Attached Garage	0	308	0	0.00	0
PTO	Patio	0	320	0	0.00	0
TQS	Three Quarter Story	741	1,140	741	179.73	204,892
WDK	Wood Deck	0	542	0	0.00	0
Ttl Gross Liv / Lease Area		1,997	4,710	1,997		552,185

