

| CURRENT OWNER | | | TOPO | UTILITIES | STRT / ROAD | LOCATION | CURRENT ASSESSMENT | | | | |
|----------------------------|--|--|--------------------------|-----------|-------------|-----------------------|--------------------|------|----------|----------|---------------------------------|
| BLUE STREAM PROPERTIES LLC | | | | | | | Description | Code | Assessed | Assessed | 801 FY2024 BARNSTABLE, MA |
| 60 EAST STREET (REAR) | | | | | | | RESIDENTL | 1010 | 490,200 | 490,200 | |
| WARE MA 01082 | | | | | | | RES LAND | 1010 | 246,900 | 246,900 | |
| SUPPLEMENTAL DATA | | | | | | | | | | | |
| Alt Prcl ID | | | Plan Ref. 475/53; 307/63 | | | | | | | | |
| Split Zonin | | | Land Ct# | | | | | | | | |
| BID Parcel | | | #SR | | | | | | | | |
| ResExpt Q | | | Life Estate | | | | | | | | |
| #DL 1 UNNUM LOT; PARCELA | | | PP STATU | | | | | | | | |
| #DL 2 | | | Assoc Pid# | | | | | | | | |
| GIS ID F_961801_2718747 | | | | | | Total 737,100 737,100 | | | | | |

VISION

| RECORD OF OWNERSHIP | | | BK-VOL/PAGE | SALE DATE | Q/U | V/I | SALE PRIC | VC | PREVIOUS ASSESSMENTS (HISTORY) | | | | | | | | | |
|-----------------------------------|--|--|-------------|------------|-----|-----|-----------|----|--------------------------------|------|----------|------|------|----------|------|---------|----------|---------|
| BLUE STREAM PROPERTIES LLC | | | 29221 0123 | 10-23-2015 | U | I | 650,000 | 1 | Year | Code | Assessed | Year | Code | Assessed | Year | Code | Assessed | |
| MILLER, WAYNE A TR | | | 23977 0162 | 08-19-2009 | U | I | 1 | 1F | 2023 | 1010 | 448,200 | 2022 | 1010 | 389,400 | 2021 | 1010 | 258,100 | |
| MILLER, WAYNE A & SHERMAN, JOHN R | | | 15342 0216 | 07-08-2002 | U | I | 15,000 | 1A | | 1010 | 247,300 | | 1010 | 188,000 | | 1010 | 188,000 | |
| MILLER, WAYNE A & SHERMAN J TRS | | | 7693 0204 | 09-27-1991 | U | I | 1 | A | | | | | | | | 1010 | 86,100 | |
| SHERMAN, JOHN J TR | | | 7313 0235 | 10-04-1990 | U | I | 1 | A | | | | | | | | | | |
| Total | | | | | | | | | | | 695,500 | | | Total | | 577,400 | Total | 532,200 |

| EXEMPTIONS | | | | OTHER ASSESSMENTS | | | | This signature acknowledges a visit by a Data Collector or Assessor | | | | | | | | | | | | |
|------------|------|-------------|--------|-------------------|-------------|--------|--------|---|--|--|--|--|--|--|--|--|--|--|--|--|
| Year | Code | Description | Amount | Code | Description | Number | Amount | Comm Int | | | | | | | | | | | | |
| | | | | | | | | | | | | | | | | | | | | |
| Total | | | 0.00 | | | | | | | | | | | | | | | | | |

| ASSESSING NEIGHBORHOOD | | | | APPRAISED VALUE SUMMARY | | | | | | | | | | | | |
|------------------------|-----------|---|---------|-------------------------|--|--|--|--|--|--|--|--|--|--|--|--|
| Nbhd | Nbhd Name | B | Tracing | Batch | | | | | | | | | | | | |
| 0106 | | | | WBARNS | | | | | | | | | | | | |

| NOTES | | | | | | | | | | | | APPRAISED VALUE SUMMARY | | | | | | |
|-------|--|--|--|--|--|--|--|--|--|--|--|-------------------------------|--|--|--|--|--|---------|
| | | | | | | | | | | | | Appraised Bldg. Value (Card) | | | | | | 365,100 |
| | | | | | | | | | | | | Appraised Xf (B) Value (Bldg) | | | | | | 39,000 |
| | | | | | | | | | | | | Appraised Ob (B) Value (Bldg) | | | | | | 86,100 |
| | | | | | | | | | | | | Appraised Land Value (Bldg) | | | | | | 246,900 |
| | | | | | | | | | | | | Special Land Value | | | | | | 0 |
| | | | | | | | | | | | | Total Appraised Parcel Value | | | | | | 737,100 |
| | | | | | | | | | | | | Valuation Method | | | | | | C |
| | | | | | | | | | | | | Total Appraised Parcel Value | | | | | | 737,100 |

| BUILDING PERMIT RECORD | | | | | | | | | | VISIT / CHANGE HISTORY | | | | | |
|------------------------|------------|------|----------------|--------|------------|--------|------------|----------------------------------|--|------------------------|----|------|----|----|-----------------------|
| Permit Id | Issue Date | Type | Description | Amount | Insp Date | % Comp | Date Comp | Comments | | Date | Id | Type | Is | Cd | Purpost/Result |
| 18-3811 | 11-27-2018 | 838 | Solar Panel-Co | 70,000 | 03-04-2019 | 100 | 06-30-2019 | Install 5 solar PV canopies ove | | 05-19-2020 | DM | | | FR | Field Review |
| 18-2043 | 08-23-2018 | 838 | Solar Panel-Co | 24,000 | 03-04-2019 | 100 | 06-30-2019 | 12 kW solar installation on bar | | 03-04-2019 | SR | 01 | | 02 | Bldg Permit Completed |
| 18-1018 | 06-12-2018 | 838 | Solar Panel-Co | 63,700 | 12-12-2018 | 100 | 06-30-2019 | Install 5 solar photovoltaic can | | 08-03-2018 | SR | 02 | | 13 | CALL BACK |
| 17-2999 | 10-23-2017 | 839 | Solar Panel-Re | 24,000 | 04-23-2018 | 0 | | EXPIRED 12 KW solar installa | | 10-12-2017 | SR | 01 | | 03 | Cycl Insp Comp |
| 201500232 | 01-14-2015 | NR | New Roof | 5,821 | 06-30-2015 | 100 | 06-30-2016 | RE-ROOF STRIPPING OLD S | | 06-13-2014 | JR | 03 | | 16 | In Office Review |
| 70783 | 08-13-2003 | OB | Out Building | 40,000 | 10-07-2003 | 100 | 01-01-2004 | | | 05-21-2009 | JR | 03 | | 16 | In Office Review |
| 35125 | 12-03-1998 | AD | Addition | 35,000 | 03-19-2001 | 100 | 01-01-2001 | | | 01-31-2008 | PT | 02 | | 14 | Cyclical Inspection |

| LAND LINE VALUATION SECTION | | | | | | | | | | | | | | | | | | | |
|-----------------------------|----------|----------------|------|----|------------|---------------|------------------------|---------|------------|-------|-------|-----------|------------------|--------------------|------------|------------|---------|---------|--|
| B | Use Code | Description | Zone | LA | Land Units | Unit Price | Size Adj | AC Disc | Site Index | Cond. | Nbhd. | Nbhd. Adj | Notes | Location Adjustmen | Adj Unit P | Land Value | | | |
| 1 | 1010 | Single Fam M-0 | RF | 5 | 1.000 | AC 176,344.00 | 1.00000 | 1.0000 | 5 | 1.00 | 0106 | 1.150 | WETLAND | | 1.0000 | 202,795.6 | 202,800 | | |
| 1 | 1010 | Single Fam M-0 | RF | 5 | 4.740 | AC 2,375.00 | 1.00000 | 1.0000 | 0 | 1.00 | WTL | 1.000 | | | 1.0000 | 2,375 | 11,300 | | |
| 1 | 1010 | Single Fam M-0 | RF | 5 | 2.000 | AC 14,250.00 | 1.00000 | 1.0000 | 0 | 1.00 | 0106 | 1.150 | | | 1.0000 | 16,387.5 | 32,800 | | |
| Total Card Land Units | | | | | 7.74 | AC | Parcel Total Land Area | | | | | 7.74 | Total Land Value | | | | | 246,900 | |

| CONSTRUCTION DETAIL | | | CONSTRUCTION DETAIL (CONTINUED) | | |
|---------------------|----|----------------|---------------------------------|------|-------------|
| Element | Cd | Description | Element | Cd | Description |
| Style | 04 | Cape Cod | | | |
| Model | 01 | Residential | | | |
| Grade: | C | Average | | | |
| Stories | 2 | 2 Stories | | | |
| Exterior Wall 1 | 14 | Wood Shingle | | | |
| Exterior Wall 2 | 11 | Clapboard | | | |
| Roof Structure | 03 | Gable/Hip | | | |
| Roof Cover | 03 | Asph/F Gls/Cmp | | | |
| Interior Wall 1 | 05 | Drywall | | | |
| Interior Wall 2 | | | | | |
| Interior Floor 1 | 14 | Carpet | | | |
| Interior Floor 2 | | | | | |
| Heat Fuel | 02 | Oil | | | |
| Heat Type | 04 | Hot Air | | | |
| AC Type | 03 | Central | | | |
| Bedrooms | 02 | 2 Bedrooms | | | |
| Full Baths | 2 | | | | |
| Half Baths | 0 | | | | |
| Extra Fixtures | | | | | |
| Total Rooms | 6 | | | | |
| Bath Style | | | | | |
| Kitchen Style | | | | | |
| Occupancy | | | | | |
| Usrflid 105 | | | | | |
| Accessory Apt | | | | | |
| Foundation Alt | 01 | Poured Conc. | | | |
| Rms Prts | | | | | |
| Bath Split | 20 | 2 Full-0 Half | | | |
| | | | CONDO DATA | | |
| | | | Parcel Id | C | Owne 0.0 |
| | | | | B | S |
| | | | Adjust Type | Code | Description |
| | | | Condo Flr | | Factor% |
| | | | Condo Unit | | |
| | | | COST / MARKET VALUATION | | |
| | | | Building Value New | | 439,835 |
| | | | Year Built | | 1983 |
| | | | Effective Year Built | | 1997 |
| | | | Depreciation Code | | A |
| | | | Remodel Rating | | |
| | | | Year Remodeled | | |
| | | | Depreciation % | | 17 |
| | | | Functional Obsol | | 0 |
| | | | External Obsol | | 0 |
| | | | Trend Factor | | 1 |
| | | | Condition | | |
| | | | Condition % | | |
| | | | Percent Good | | 83 |
| | | | RCNLD | | 365,100 |
| | | | Dep % Ovr | | |
| | | | Dep Ovr Comment | | |
| | | | Misc Imp Ovr | | |
| | | | Misc Imp Ovr Comment | | |
| | | | Cost to Cure Ovr | | |
| | | | Cost to Cure Ovr Comment | | |

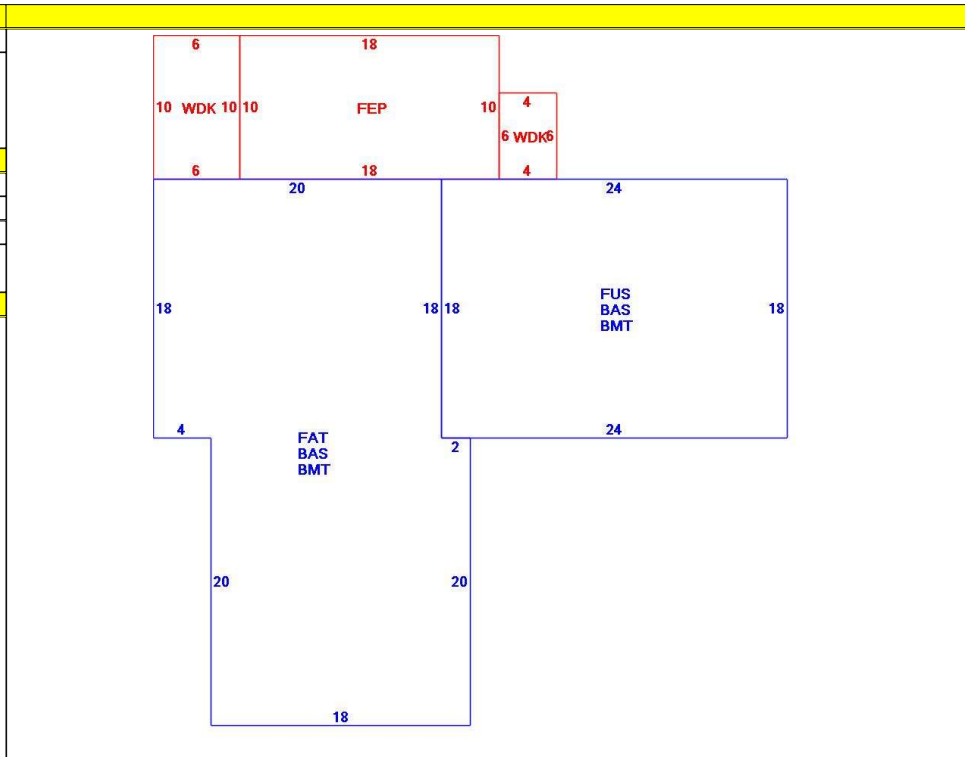

| OB - OUTBUILDING & YARD ITEMS(L) / XF - BUILDING EXTRA FEATURES(B) | | | | | | | | | | |
|--|-----------------|-----|-------|------------|--------|----------|------|-------|------------|-------------|
| Code | Description | L/B | Units | Unit Price | Yr Blt | Cond. Cd | % Gd | Grade | Grade Adj. | Appr. Value |
| FPL2 | Fireplace 1.5 s | B | 1 | 6000.00 | 1999 | | 83 | | 0.00 | 5,000 |
| SHD2 | Shed w/Elec | L | 320 | 26.00 | 2000 | | 62 | | 0.00 | 5,200 |
| GRN5 | COMM-poly,st | L | 3,000 | 11.75 | 2000 | | 62 | 00 | 1.00 | 21,900 |
| BRN3 | Barn w loft | L | 1,500 | 39.66 | 2003 | | 84 | 00 | 1.00 | 50,000 |
| WDC | Wood Decking | L | 84 | 20.00 | 2004 | | 70 | | 0.00 | 2,400 |
| FEP | Enclosed porc | B | 180 | 70.00 | 1999 | | 83 | | 0.00 | 9,800 |
| BMT | Basement-Unfi | B | 1,152 | 26.01 | 1999 | | 83 | | 0.00 | 24,200 |
| SHD2 | Shed w/Elec | L | 168 | 26.00 | 2000 | | 62 | | 0.00 | 2,700 |
| GEN | Emergency Ge | L | 1 | 5550.00 | 2004 | | 70 | | 0.00 | 3,900 |
| SOL2 | Solar PV Pane | B | 45 | 725.00 | 1999 | | 0 | | 0.00 | 0 |

| BUILDING SUB-AREA SUMMARY SECTION | | | | | | |
|-----------------------------------|-----------------|-------------|------------|----------|-----------|----------------|
| Code | Description | Living Area | Floor Area | Eff Area | Unit Cost | Undeprec Value |
| BAS | First Floor | 1,152 | 1,152 | 1,152 | 259.95 | 299,462 |
| BMT | Basement Area | 0 | 1,152 | 0 | 0.00 | 0 |
| FAT | Attic, Finished | 108 | 720 | 108 | 38.99 | 28,075 |
| FEP | Enclosed Porch | 0 | 180 | 0 | 0.00 | 0 |
| FUS | Upper Story | 432 | 432 | 432 | 259.95 | 112,298 |
| WDK | Wood Deck | 0 | 84 | 0 | 0.00 | 0 |
| Ttl Gross Liv / Lease Area | | 1,692 | 3,720 | 1,692 | | 439,835 |



| CURRENT OWNER | | TOPO | UTILITIES | STRT / ROAD | LOCATION | CURRENT ASSESSMENT | | | | 801 FY2024 BARNSTABLE, MA VISION | | | | | | |
|--|------------|---|-------------------|-------------|------------------------|--|-----------|---|------------|--|---------|-----------|----------|--------------------|----------------|------------|
| BLUE STREAM PROPERTIES LLC 60 EAST STREET (REAR) WARE MA 01082 | | | | | | Description | Code | Assessed | Assessed | | | | | | | |
| | | SUPPLEMENTAL DATA | | | | RESIDNTL | 1010 | 490,200 | 490,200 | | | | | | | |
| | | Alt Prcl ID Split Zonin BID Parcel ResExpt Q #DL 1 UNNUM LOT; PARCELA #DL 2 GIS ID F_961801_2718747 | | | | Plan Ref. 475/53; 307/63 Land Ct# #SR Life Estate PP STATU Assoc Pid# | RES LAND | 1010 | 246,900 | | | 246,900 | | | | |
| | | | | | | Total | | 737,100 | 737,100 | | | | | | | |
| RECORD OF OWNERSHIP | | BK-VOL/PAGE | SALE DATE | Q/U | V/I | SALE PRIC | VC | PREVIOUS ASSESSMENTS (HISTORY) | | | | | | | | |
| | | | | | | | | Year | Code | Assessed | Year | Code | Assessed | | | |
| | | | | | | | | 2023 | 1010 | 448,200 | 2022 | 1010 | 389,400 | | | |
| | | | | | | | | | 1010 | 247,300 | | 1010 | 188,000 | | | |
| | | | | | | | | Total | | 695,500 | Total | | 577,400 | | | |
| | | | | | | | | Total | | | Total | | 532,200 | | | |
| EXEMPTIONS | | | OTHER ASSESSMENTS | | | | | This signature acknowledges a visit by a Data Collector or Assessor | | | | | | | | |
| Year | Code | Description | Amount | Code | Description | Number | Amount | | | | | | Comm Int | | | |
| | | | | | | | | | | | | | | | | |
| Total | | | | | | | | | | | | | | | | |
| ASSESSING NEIGHBORHOOD | | | | | | | | | | APPRAISED VALUE SUMMARY | | | | | | |
| Nbhd | Nbhd Name | | B | Tracing | | Batch | | Appraised Bldg. Value (Card) | | | 365,100 | | | | | |
| 0106 | | | | | | WBARNS | | Appraised Xf (B) Value (Bldg) | | | 39,000 | | | | | |
| | | | | | | | | | | Appraised Ob (B) Value (Bldg) | | 86,100 | | | | |
| | | | | | | | | | | Appraised Land Value (Bldg) | | 246,900 | | | | |
| | | | | | | | | | | Special Land Value | | 0 | | | | |
| | | | | | | | | | | Total Appraised Parcel Value | | 737,100 | | | | |
| | | | | | | | | | | Valuation Method | | C | | | | |
| | | | | | | | | | | Total Appraised Parcel Value | | 737,100 | | | | |
| BUILDING PERMIT RECORD | | | | | | | | | | VISIT / CHANGE HISTORY | | | | | | |
| Permit Id | Issue Date | Type | Description | Amount | Insp Date | % Comp | Date Comp | Comments | | Date | Id | Type | Is | Cd | Purpost/Result | |
| | | | | | | | | | | | | | | | | |
| LAND LINE VALUATION SECTION | | | | | | | | | | | | | | | | |
| B | Use Code | Description | Zone | LA | Land Units | Unit Price | Size Adj | AC Disc | Site Index | Cond. | Nbhd. | Nbhd. Adj | Notes | Location Adjustmen | Adj Unit P | Land Value |
| | | | | | | | | | | | | | | | | |
| Total Card Land Units | | | | | Parcel Total Land Area | | | | | Total Land Value | | | | | | |

