

| CURRENT OWNER         |             | TOPO                     | UTILITIES   | STRT / ROAD | LOCATION | CURRENT ASSESSMENT |       |          |          | 801<br>FY2024<br>BARNSTABLE, MA<br><br><b>VISION</b> |
|-----------------------|-------------|--------------------------|-------------|-------------|----------|--------------------|-------|----------|----------|--|
| PACHECO, DOUGLAS A    | 1 Level     | 4 Gas                    | 1 Paved     |             |          | Description        | Code  | Assessed | Assessed |  |
|                       |             | 5 Well                   |             |             |          | RESIDNTL           | 013H  | 412,200  | 412,200  |  |
| PO BOX 472            |             | 6 Septic                 |             |             |          | RES LAND           | 013H  | 156,690  | 156,690  |  |
|                       |             | <b>SUPPLEMENTAL DATA</b> |             |             |          | COMMERC.           | 031S  | 43,470   | 43,470   |  |
| WEST BARNSTA MA 02668 | Alt Prcl ID | Split Zonin              | Plan Ref.   | Land Ct#    |          | COMMERC.           | 0325  | 50,630   | 50,630   |  |
|                       | BID Parcel  | ResExpt Q                | Life Estate | PP STATU    |          | COM LAND           | 0325  | 17,410   | 17,410   |  |
|                       | #DL 1       |                          |             |             |          |                    |       |          |          |  |
|                       | #DL 2       |                          |             |             |          |                    |       |          |          |  |
|                       | GIS ID      | F_963926_2720323         | Assoc Pid#  |             |          |                    |       |          |          |  |
|                       |             |                          |             |             |          |                    | Total | 680,400  | 680,400  |  |

| RECORD OF OWNERSHIP               |       | BK-VOL/PAGE | SALE DATE  | Q/U | V/I | SALE PRIC | VC    | PREVIOUS ASSESSMENTS (HISTORY) |         |          |      |         |          |      |         |          |
|-----------------------------------|-------|-------------|------------|-----|-----|-----------|-------|--------------------------------|---------|----------|------|---------|----------|------|---------|----------|
| PACHECO, DOUGLAS A                | 27370 | 0224        | 05-13-2013 | U   | I   | 210,000   | 1     | Year                           | Code    | Assessed | Year | Code    | Assessed | Year | Code    | Assessed |
| MOORE, SALLIE L                   | 19700 | 0098        | 04-07-2005 | U   | I   | 0         | 1     | 2023                           | 013H    | 348,570  | 2022 | 013H    | 286,380  | 2021 | 013H    | 234,720  |
| MOORE, SALLIE L & KAURANEN, EDITH | 1088  | 0172        | 08-15-1960 | U   |     | 0         |       |                                | 013H    | 142,380  |      | 013H    | 105,480  |      | 013H    | 105,480  |
|                                   |       |             |            |     |     |           |       |                                | 031S    | 43,470   |      | 031S    | 39,510   |      | 013H    | 1,080    |
|                                   |       |             |            |     |     |           |       |                                | 0325    | 43,560   |      | 0325    | 36,210   |      | 031S    | 39,510   |
|                                   |       |             |            |     |     |           |       |                                | 0325    | 44,700   |      | 0325    | 44,700   |      | 0325    | 44,700   |
|                                   |       |             |            |     |     |           | Total |                                | 593,800 | Total    |      | 479,300 | Total    |      | 423,100 |          |

| EXEMPTIONS |      |             |        | OTHER ASSESSMENTS |             |        |        | This signature acknowledges a visit by a Data Collector or Assessor |  |  |  |  |  |  |  |  |  |  |
|------------|------|-------------|--------|-------------------|-------------|--------|--------|---|--|--|--|--|--|--|--|--|--|--|
| Year       | Code | Description | Amount | Code              | Description | Number | Amount | Comm Int  |  |  |  |  |  |  |  |  |  |  |
|            |      |             |        |                   |             |        |        |   |  |  |  |  |  |  |  |  |  |  |
|            |      |             | Total  | 0.00              |             |        |        |   |  |  |  |  |  |  |  |  |  |  |

| ASSESSING NEIGHBORHOOD |           |   |         | APPRAISED VALUE SUMMARY |                               |  |  |  |  |         |
|------------------------|-----------|---|---------|-------------------------|-------------------------------|--|--|--|--|---------|
| Nbhd                   | Nbhd Name | B | Tracing | Batch                   |                               |  |  |  |  |         |
| 0105                   |           |   | WBARN   |                         | Appraised Bldg. Value (Card)  |  |  |  |  | 485,200 |
|                        |           |   |         |                         | Appraised Xf (B) Value (Bldg) |  |  |  |  | 19,900  |
|                        |           |   |         |                         | Appraised Ob (B) Value (Bldg) |  |  |  |  | 1,200   |
|                        |           |   |         |                         | Appraised Land Value (Bldg)   |  |  |  |  | 174,100 |
|                        |           |   |         |                         | Special Land Value            |  |  |  |  | 0       |
|                        |           |   |         |                         | Total Appraised Parcel Value  |  |  |  |  | 680,400 |
|                        |           |   |         |                         | Valuation Method              |  |  |  |  | C       |
|                        |           |   |         |                         | Total Appraised Parcel Value  |  |  |  |  | 680,400 |

| NOTES     |            |      |             |        |            |        |            |                          |  | VISIT / CHANGE HISTORY |    |      |    |    |                       |
|-----------|------------|------|-------------|--------|------------|--------|------------|--------------------------|--|------------------------|----|------|----|----|-----------------------|
| Permit Id | Issue Date | Type | Description | Amount | Insp Date  | % Comp | Date Comp  | Comments                 |  | Date                   | Id | Type | Is | Cd | Purpost/Result        |
| 17-964    | 04-10-2017 | 822  | Insulation  | 0      |            | 100    |            | Weatherization           |  | 05-06-2020             | GM | 04   |    | FR | Field Review          |
| 201403780 | 06-10-2014 | NS   | New Siding  | 1,000  | 06-30-2015 | 100    | 06-30-2015 | RE-SIDE BARN & INSTALL 5 |  | 01-20-2016             | TW | 03   |    | 16 | In Office Review      |
| 201308292 | 11-14-2013 | IN   | Insulation  | 1,500  | 06-30-2014 | 100    | 06-30-2014 | INSULATE                 |  | 08-04-2015             | SR | 02   |    | 03 | Cycl Insp Comp        |
| 201303660 | 07-05-2013 | RE   | Remodel     | 10,000 | 04-01-2014 | 100    | 06-30-2014 | RENO-GUT KIT CONVERT T   |  | 04-15-2014             | MW | 02   |    | 02 | Bldg Permit Completed |
| B35797    | 04-01-1993 | AD   | Addition    | 3,400  | 01-15-1994 | 100    | 01-15-1994 | WB ALTER.                |  | 01-31-2008             | PT | 02   |    | 14 | Cyclical Inspection   |
| B33007    | 06-01-1989 | DE   | Demolish    | 0      | 01-15-1990 | 100    | 01-15-1990 | WB PORTIO                |  | 06-08-2007             | JK | 03   |    | 16 | In Office Review      |
|           |            |      |             |        |            |        |            |                          |  | 06-07-2007             | SF | 03   |    | 16 | In Office Review      |

| LAND LINE VALUATION SECTION |          |             |      |    |                       |            |            |                        |            |       |       |           |       |                    |            |            |                  |         |
|-----------------------------|----------|-------------|------|----|-----------------------|------------|------------|------------------------|------------|-------|-------|-----------|-------|--------------------|------------|------------|------------------|---------|
| B                           | Use Code | Description | Zone | LA | Land Units            | Unit Price | Size Adj   | AC Disc                | Site Index | Cond. | Nbhd. | Nbhd. Adj | Notes | Location Adjustmen | Adj Unit P | Land Value |                  |         |
| 1                           | 013H     | RES PART MU | WBV  | 5  | 0.860                 | AC         | 176,344.00 | 1.14768                | 1.0000     | 5     | 1.00  | 0105      | 1.000 |                    | 1.0000     | 202,390.0  | 174,100          |         |
|                             |          |             |      |    | Total Card Land Units | 0.86       | AC         | Parcel Total Land Area |            |       |       |           | 0.86  |                    |            |            | Total Land Value | 174,100 |

| CONSTRUCTION DETAIL |     |                | CONSTRUCTION DETAIL (CONTINUED) |    |             |
|---------------------|-----|----------------|---------------------------------|----|-------------|
| Element             | Cd  | Description    | Element                         | Cd | Description |
| Style               | 06  | Conventional   |                                 |    |             |
| Model               | 01  | Residential    |                                 |    |             |
| Grade:              | C   | Average        |                                 |    |             |
| Stories             | 2.2 |                |                                 |    |             |
| Exterior Wall 1     | 14  | Wood Shingle   |                                 |    |             |
| Exterior Wall 2     | 11  | Clapboard      |                                 |    |             |
| Roof Structure      | 03  | Gable/Hip      |                                 |    |             |
| Roof Cover          | 03  | Asph/F Gls/Cmp |                                 |    |             |
| Interior Wall 1     | 03  | Plastered      |                                 |    |             |
| Interior Wall 2     |     |                |                                 |    |             |
| Interior Floor 1    | 09  | Pine/Soft Wood |                                 |    |             |
| Interior Floor 2    |     |                |                                 |    |             |
| Heat Fuel           | 02  | Oil            |                                 |    |             |
| Heat Type           | 04  | Hot Air        |                                 |    |             |
| AC Type             | 01  | None           |                                 |    |             |
| Bedrooms            | 04  | 4 Bedrooms     |                                 |    |             |
| Full Baths          | 2   |                |                                 |    |             |
| Half Baths          | 1   |                |                                 |    |             |
| Extra Fixtures      |     |                |                                 |    |             |
| Total Rooms         | 8   | 8 Rooms        |                                 |    |             |
| Bath Style          |     |                |                                 |    |             |
| Kitchen Style       |     |                |                                 |    |             |
| Occupancy           |     |                |                                 |    |             |
| Usrflid 105         |     |                |                                 |    |             |
| Accessory Apt       |     |                |                                 |    |             |
| Foundation Alt      | 04  | Brick Walls    |                                 |    |             |
| Rms Prts            |     |                |                                 |    |             |
| Bath Split          | 21  | 2 Full-1 Half  |                                 |    |             |

| CONDO DATA  |      |             |         |     |
|-------------|------|-------------|---------|-----|
| Parcel Id   |      | C           | Owne    | 0.0 |
| Adjust Type | Code | Description | Factor% |     |
| Condo Flr   |      |             |         |     |
| Condo Unit  |      |             |         |     |

| COST / MARKET VALUATION  |         |
|--------------------------|---------|
| Building Value New       | 633,150 |
| Year Built               | 1850    |
| Effective Year Built     | 1979    |
| Depreciation Code        | A       |
| Remodel Rating           |         |
| Year Remodeled           |         |
| Depreciation %           | 31      |
| Functional Obsol         | 0       |
| External Obsol           | 0       |
| Trend Factor             | 1       |
| Condition                |         |
| Condition %              |         |
| Percent Good             | 69      |
| RCNLD                    | 436,900 |
| Dep % Ovr                |         |
| Dep Ovr Comment          |         |
| Misc Imp Ovr             |         |
| Misc Imp Ovr Comment     |         |
| Cost to Cure Ovr         |         |
| Cost to Cure Ovr Comment |         |

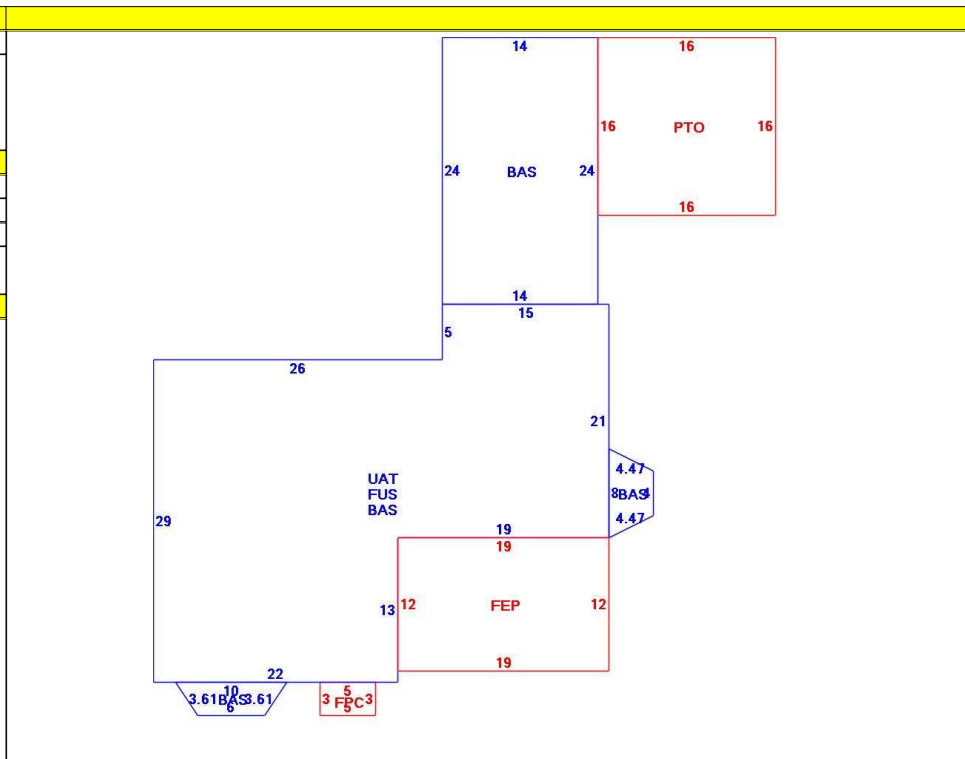

| OB - OUTBUILDING & YARD ITEMS(L) / XF - BUILDING EXTRA FEATURES(B) |                 |     |       |            |        |          |      |       |            |             |
|--|-----------------|-----|-------|------------|--------|----------|------|-------|------------|-------------|
| Code   | Description     | L/B | Units | Unit Price | Yr Blt | Cond. Cd | % Gd | Grade | Grade Adj. | Appr. Value |
| BRN3   | Barn w loft     | L   | 840   | 39.66      | 1920   |          | 1    | 00    | 1.00       | 300         |
| PAT1   | Patio- Average  | L   | 256   | 5.89       | 1976   |          | 57   |       | 0.00       | 900         |
| FEP  | Enclosed porc   | B   | 228   | 70.00      | 1979   |          | 69   |       | 0.00       | 9,400       |
| FOPC   | Open Prch-roo   | B   | 15    | 55.00      | 1979   |          | 69   |       | 0.00       | 800         |
| FPL3   | Fireplace 2 sto | B   | 2     | 7000.00    | 1979   |          | 69   |       | 0.00       | 9,700       |

| BUILDING SUB-AREA SUMMARY SECTION |                        |             |            |          |           |                |
|-----------------------------------|------------------------|-------------|------------|----------|-----------|----------------|
| Code                              | Description            | Living Area | Floor Area | Eff Area | Unit Cost | Undeprec Value |
| BAS                               | First Floor            | 1,401       | 1,401      | 1,401    | 251.25    | 352,001        |
| FEP                               | Enclosed Porch         | 0           | 228        | 0        | 0.00      | 0              |
| FPC                               | Open Porch Conc. Floor | 0           | 15         | 0        | 0.00      | 0              |
| FUS                               | Upper Story            | 1,017       | 1,017      | 1,017    | 251.25    | 255,521        |
| PTO                               | Patio                  | 0           | 256        | 0        | 0.00      | 0              |
| UAT                               | Attic, Unfinished      | 0           | 1,017      | 102      | 25.20     | 25,628         |
| Ttl Gross Liv / Lease Area        |                        | 2,418       | 3,934      | 2,520    |           | 633,150        |



| CURRENT OWNER   |         | TOPO     | UTILITIES   | STRT / ROAD | LOCATION | CURRENT ASSESSMENT |      |           |          | 801<br>FY2024<br>BARNSTABLE, MA<br><br><b>VISION</b> |
|---|---------|----------|-------------|-------------|----------|--------------------|------|-----------|----------|--|
| PACHECO, DOUGLAS A<br><br>PO BOX 472<br><br>WEST BARNSTA MA 02668 | 1 Level | 4 Gas    | 1 Paved     |             |          | Description        | Code | Appraised | Assessed |  |
|   |         | 5 Well   |             |             |          | RESIDNTL           | 013H | 412,200   | 412,200  |  |
|   |         | 6 Septic |             |             |          | RES LAND           | 013H | 156,690   | 156,690  |  |
| <b>SUPPLEMENTAL DATA</b>  |         |          |             |             |          | COMMERC.           | 031S | 43,470    | 43,470   |  |
| Alt Prcl ID   |         |          | Plan Ref.   |             |          | COMMERC.           | 0325 | 50,630    | 50,630   |  |
| Split Zonin   |         |          | Land Ct#    |             |          | COM LAND           | 0325 | 17,410    | 17,410   |  |
| BID Parcel  |         |          | #SR         |             |          |                    |      |           |          |  |
| ResExpt Q   |         |          | Life Estate |             |          |                    |      |           |          |  |
| #DL 1   |         |          | PP STATU    |             |          |                    |      |           |          |  |
| #DL 2   |         |          |             |             |          |                    |      |           |          |  |
| GIS ID F_963926_2720323   |         |          | Assoc Pid#  |             |          |                    |      |           |          |  |
|   |         |          |             |             |          | Total              |      | 680,400   | 680,400  |  |

| RECORD OF OWNERSHIP                 |       | BK-VOL/PAGE | SALE DATE  | Q/U | V/I | SALE PRICE | VC | PREVIOUS ASSESSMENTS (HISTORY) |      |          |       |      |          |       |      |          |
|-------------------------------------|-------|-------------|------------|-----|-----|------------|----|--------------------------------|------|----------|-------|------|----------|-------|------|----------|
| PACHECO, DOUGLAS A                  | 27370 | 0224        | 05-13-2013 | U   | I   | 210,000    | 1  | Year                           | Code | Assessed | Year  | Code | Assessed | Year  | Code | Assessed |
| MOORE, SALLIE L                     | 19700 | 0098        | 04-07-2005 | U   | I   | 0          | 1  | 2023                           | 013H | 348,570  | 2022  | 013H | 286,380  | 2021  | 013H | 234,720  |
| MOORE, SALLIE L & KAURANEN, EDITH E | 1088  | 0172        | 08-15-1960 | U   |     | 0          |    |                                | 013H | 142,380  |       | 013H | 105,480  |       | 013H | 105,480  |
|                                     |       |             |            |     |     |            |    |                                | 031S | 43,470   |       | 031S | 39,510   |       | 031S | 1,080    |
|                                     |       |             |            |     |     |            |    |                                | 0325 | 43,560   |       | 0325 | 36,210   |       | 031S | 39,510   |
|                                     |       |             |            |     |     |            |    |                                | 0325 | 45,800   |       | 0325 | 44,700   |       | 0325 | 20,470   |
|                                     |       |             |            |     |     |            |    | Total                          |      | 593,800  | Total |      | 479,300  | Total |      | 423,100  |

| EXEMPTIONS |      |             | OTHER ASSESSMENTS |      |             |        |        | This signature acknowledges a visit by a Data Collector or Assessor |  |  |  |  |  |  |  |  |  |  |
|------------|------|-------------|-------------------|------|-------------|--------|--------|---|--|--|--|--|--|--|--|--|--|--|
| Year       | Code | Description | Amount            | Code | Description | Number | Amount | Comm Int  |  |  |  |  |  |  |  |  |  |  |
|            |      |             |                   |      |             |        |        |   |  |  |  |  |  |  |  |  |  |  |
|            |      |             |                   |      |             |        |        |   |  |  |  |  |  |  |  |  |  |  |
|            |      |             |                   |      |             |        |        |   |  |  |  |  |  |  |  |  |  |  |
|            |      |             | Total             |      |             |        | 0.00   |   |  |  |  |  |  |  |  |  |  |  |

| ASSESSING NEIGHBORHOOD |           |   |         |        | APPRAISED VALUE SUMMARY      |                               |                               |                             |                    |                              |                  |
|------------------------|-----------|---|---------|--------|------------------------------|-------------------------------|-------------------------------|-----------------------------|--------------------|------------------------------|------------------|
| Nbhd                   | Nbhd Name | B | Tracing | Batch  | Appraised Bldg. Value (Card) | Appraised Xf (B) Value (Bldg) | Appraised Ob (B) Value (Bldg) | Appraised Land Value (Bldg) | Special Land Value | Total Appraised Parcel Value | Valuation Method |
| 0105                   |           |   |         | WBARN5 | 485,200                      | 19,900                        | 1,200                         | 174,100                     | 0                  | 680,400                      | C                |
|                        |           |   |         |        | Total Appraised Parcel Value | 680,400                       |                               |                             |                    |                              |                  |

| BUILDING PERMIT RECORD |            |      |             |        |           |        |           |          |      | VISIT / CHANGE HISTORY |      |    |    |                |  |
|------------------------|------------|------|-------------|--------|-----------|--------|-----------|----------|------|------------------------|------|----|----|----------------|--|
| Permit Id              | Issue Date | Type | Description | Amount | Insp Date | % Comp | Date Comp | Comments | Date | Id                     | Type | Is | Cd | Purpost/Result |  |
|                        |            |      |             |        |           |        |           |          |      |                        |      |    |    |                |  |

| LAND LINE VALUATION SECTION |          |             |      |    |           |            |            |                              |            |       |       |          |       |                   |               |            |  |  |         |
|-----------------------------|----------|-------------|------|----|-----------|------------|------------|------------------------------|------------|-------|-------|----------|-------|-------------------|---------------|------------|--|--|---------|
| B                           | Use Code | Description | Zone | LA | Land Type | Land Units | Unit Price | I. Factor                    | Site Index | Cond. | Nbhd. | Nbhd Adj | Notes | Location Adjustme | Adj Unit Pric | Land Value |  |  |         |
| 2                           | 031S     | MU STORE    | WBV  | 5  |           | 0 SF       | 0.00       | 1.00000                      | 5          | 1.00  |       | 1.000    |       | 0                 | 0             | 0          |  |  |         |
| Total Card Land Units       |          |             |      |    |           | 0.00       | AC         | Parcel Total Land Area: 0.86 |            |       |       |          |       | Total Land Value  |               |            |  |  | 174,100 |

| CONSTRUCTION DETAIL |       |                | CONSTRUCTION DETAIL (CONTINUED) |    |             |
|---------------------|-------|----------------|---------------------------------|----|-------------|
| Element             | Cd    | Description    | Element                         | Cd | Description |
| Style               | 12    | Comm Bldg      |                                 |    |             |
| Model               | 94    | Commercial     |                                 |    |             |
| Grade               | E     | Economy        |                                 |    |             |
| Stories             | 1.3   |                |                                 |    |             |
| Occupancy           | 1.00  |                |                                 |    |             |
| Exterior Wall 1     | 14    | Wood Shingle   |                                 |    |             |
| Exterior Wall 2     |       |                |                                 |    |             |
| Roof Structure      | 03    | Gable/Hip      |                                 |    |             |
| Roof Cover          | 03    | Asph/F Gls/Cmp |                                 |    |             |
| Interior Wall 1     | 05    | Drywall        |                                 |    |             |
| Interior Wall 2     |       |                |                                 |    |             |
| Interior Floor 1    | 09    | Pine/Soft Wood |                                 |    |             |
| Interior Floor 2    |       |                |                                 |    |             |
| Heating Fuel        | 01    | None           |                                 |    |             |
| Heating Type        | 01    | None           |                                 |    |             |
| AC Type             | 01    | None           |                                 |    |             |
| Size Adj Tbl        | 031S  | MU STORE       |                                 |    |             |
| Total Rooms         |       |                |                                 |    |             |
| Bedrooms            | 01    |                |                                 |    |             |
| Full Bathrooms      | 0     |                |                                 |    |             |
| Bath Split          | 00    | 0 Full-0 Half  |                                 |    |             |
| Rms/Partitions      | 05    |                |                                 |    |             |
| Heat/AC             | 00    | NONE           |                                 |    |             |
| Frame Type          | 02    | WOOD FRAME     |                                 |    |             |
| Baths/Plumbing      | 02    | AVERAGE        |                                 |    |             |
| Ceiling/Wall        | 08    | TYPICAL        |                                 |    |             |
| Common Wall         | 00    | 0%             |                                 |    |             |
| Wall Height         | 10.00 |                |                                 |    |             |
| 1st Floor Use:      | 0101  |                |                                 |    |             |
| Sewer Occupan       |       |                |                                 |    |             |

| OB - OUTBUILDING & YARD ITEMS(L) / XF - BUILDING EXTRA FEATURES(B) |             |     |       |            |        |          |        |       |           |             |
|--|-------------|-----|-------|------------|--------|----------|--------|-------|-----------|-------------|
| Code   | Description | L/B | Units | Unit Price | Yr Blt | Cond. Cd | % Good | Grade | Grade Adj | Appr. Value |
|  |             |     |       |            |        |          |        |       |           |             |

| BUILDING SUB-AREA SUMMARY SECTION |                   |             |            |          |           |                |  |
|-----------------------------------|-------------------|-------------|------------|----------|-----------|----------------|--|
| Code                              | Description       | Living Area | Floor Area | Eff Area | Unit Cost | Undeprec Value |  |
| BAS                               | First Floor       | 1,801       | 1,801      | 1,801    | 44.31     | 79,809         |  |
| FOP                               | Open Porch        | 0           | 165        | 25       | 6.71      | 1,108          |  |
| UAT                               | Attic, Unfinished | 0           | 920        | 230      | 11.08     | 10,192         |  |
| Ttl Gross Liv / Lease Area        |                   | 1,801       | 2,886      | 2,056    |           | 91,109         |  |

