

CURRENT OWNER		TOPO	UTILITIES	STRT / ROAD	LOCATION	CURRENT ASSESSMENT				801 FY2024 BARNSTABLE, MA VISION	
COOK, KATHLEEN A & CHRISTOPHE						Description	Code	Assessed	Assessed		
130 SCHOONER LANE		SUPPLEMENTAL DATA				RESIDNTL	1010	401,900	401,900		
HYANNIS MA 02601		Alt Prcl ID Split Zonin BID Parcel ResExpt Q YES: #DL 1 LOT 27 #DL 2 GIS ID F_981700_2706222				Plan Ref. 610/95-96 Land Ct# #SR Life Estate PP STATU Assoc Pid#		RES LAND	1010	168,700	168,700
						Total		570,600	570,600		

RECORD OF OWNERSHIP		BK-VOL/PAGE	SALE DATE	Q/U	V/I	SALE PRIC	VC	PREVIOUS ASSESSMENTS (HISTORY)								
COOK, KATHLEEN A & CHRISTOPHER		32038 0240	05-23-2019	Q	I	405,000	00	Year	Code	Assessed	Year	Code	Assessed	Year	Code	Assessed
KING, SUSAN		25475 0279	05-27-2011	Q	I	325,000	00	2023	1010	360,400	2022	1010	302,700	2021	1010	257,600
MORIN, JACQUES N TR		21605 0194	12-13-2006	U	I	1	1F		1010	166,700		1010	118,500		1010	118,500
						Total		527,100		Total		421,200		Total		379,600

EXEMPTIONS			OTHER ASSESSMENTS					
Year	Code	Description	Amount	Code	Description	Number	Amount	Comm Int
2022	5C	RESIDENTIAL EXEMPTION						
Total			0.00					

ASSESSING NEIGHBORHOOD			
Nbhd	Nbhd Name	B	Tracing
0106			Batch HYAN

NOTES			
This signature acknowledges a visit by a Data Collector or Assessor			
APPRAISED VALUE SUMMARY			
Appraised Bldg. Value (Card)			358,600
Appraised Xf (B) Value (Bldg)			39,800
Appraised Ob (B) Value (Bldg)			3,500
Appraised Land Value (Bldg)			168,700
Special Land Value			0
Total Appraised Parcel Value			570,600
Valuation Method			C
Total Appraised Parcel Value			570,600

BUILDING PERMIT RECORD								VISIT / CHANGE HISTORY						
Permit Id	Issue Date	Type	Description	Amount	Insp Date	% Comp	Date Comp	Comments	Date	Id	Type	Is	Cd	Purpost/Result
20065492	12-29-2006	DW	Dwelling	169,312	08-07-2007	100		NEW DW;C/O 9/11/07; LEXIN	08-24-2021	LH	03		16	In Office Review
									08-24-2021	LH	03		22	Change of Address
									04-27-2020	WD			FR	Field Review
									03-02-2020	SAF			20	Sale Review
									12-18-2017	SR	02		03	Cycl Insp Comp
									07-01-2008	NF	04		44	Drive by inspection only
									05-28-2008	NF	02		01	Meas/Est

LAND LINE VALUATION SECTION																	
B	Use Code	Description	Zone	LA	Land Units	Unit Price	Size Adj	AC Disc	Site Index	Cond.	Nbhd.	Nbhd. Adj	Notes	Location Adjustmen	Adj Unit P	Land Value	
1	1010	Single Fam M-0	RC-	4	0.230 AC	176,344.00	3.61599	1.0000	5	1.00	0106	1.150		1.0000	733,308.8	168,700	
Total Card Land Units					0.23 AC	Parcel Total Land Area					0.23	Total Land Value					168,700

CONSTRUCTION DETAIL			CONSTRUCTION DETAIL (CONTINUED)		
Element	Cd	Description	Element	Cd	Description
Style	04	Cape Cod			
Model	01	Residential			
Grade:	C	Average			
Stories	1.75	1 3/4 Stories			
Exterior Wall 1	14	Wood Shingle			
Exterior Wall 2	11	Clapboard			
RooF Structure	03	Gable/Hip			
RooF Cover	03	Asph/F Gls/Cmp			
Interior Wall 1	05	Drywall			
Interior Wall 2					
Interior Floor 1	12	Hardwood			
Interior Floor 2					
Heat Fuel	03	Gas			
Heat Type	04	Hot Air			
AC Type	03	Central			
Bedrooms	03	3 Bedrooms			
Full Baths	2				
Half Baths	1				
Extra Fixtures					
Total Rooms	6				
Bath Style					
Kitchen Style	02	Modernized			
Occupancy					
Usrflid 105					
Accessory Apt					
Foundation Alt	01	Poured Conc.			
Rms Prts					
Bath Split	21	2 Full-1 Half			

CONDO DATA				
Parcel Id		C	Owne	0.0
Adjust Type	Code	Description	Factor%	
Condo Flr				
Condo Unit				

COST / MARKET VALUATION		
Building Value New		389,759
Year Built		2007
Effective Year Built		2009
Depreciation Code		A
Remodel Rating		
Year Remodeled		
Depreciation %		8
Functional Obsol		0
External Obsol		0
Trend Factor		1
Condition		
Condition %		
Percent Good		92
RCNLD		358,600
Dep % Ovr		
Dep Ovr Comment		
Misc Imp Ovr		
Misc Imp Ovr Comment		
Cost to Cure Ovr		
Cost to Cure Ovr Comment		

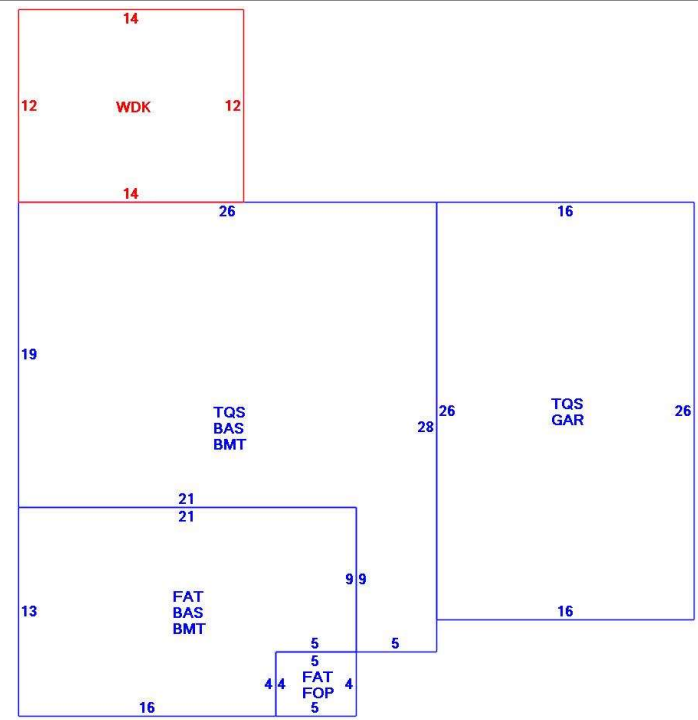

OB - OUTBUILDING & YARD ITEMS(L) / XF - BUILDING EXTRA FEATURES(B)										
Code	Description	L/B	Units	Unit Price	Yr Blt	Cond. Cd	% Gd	Grade	Grade Adj.	Appr. Value
FPLG	Gas Fireplace	B	1	2500.00	2011		92		0.00	2,300
WDC	Wood Decking	L	168	20.00	2009		80		0.00	3,500
FOP	Open Porch-ro	B	20	55.00	2011		92		0.00	1,700
GAR	Attached Gara	B	416	40.00	2011		92		0.00	15,100
BMT	Basement-Unfi	B	792	26.01	2011		92		0.00	20,700

BUILDING SUB-AREA SUMMARY SECTION						
Code	Description	Living Area	Floor Area	Eff Area	Unit Cost	Undeprec Value
BAS	First Floor	792	792	792	268.06	212,304
BMT	Basement Area	0	792	0	0.00	0
FAT	Attic, Finished	41	273	41	40.26	10,990
FOP	Open Porch	0	20	0	0.00	0
GAR	Attached Garage	0	416	0	0.00	0
TQS	Three Quarter Story	621	955	621	174.31	166,465
WDK	Wood Deck	0	168	0	0.00	0
Ttl Gross Liv / Lease Area		1,454	3,416	1,454		389,759

