

| CONSTRUCTION DETAIL | | | CONSTRUCTION DETAIL (CONTINUED) | | |
|--------------------------------|---------------|----------------|---------------------------------|-----|-------------|
| Element | Cd | Description | Element | Cd | Description |
| Style | 55 | Condominium | | | |
| Model | 05 | Res Condo | | | |
| Bedrm Func | C | Average | | | |
| Stories | 2 | 2 Stories | | | |
| Occupancy | | | | | |
| Interior Wall 1 | 05 | Drywall | | | |
| Interior Wall 2 | | | | | |
| Interior Floor 1 | 14 | Carpet | | | |
| Interior Floor 2 | | | | | |
| Heat Fuel | 03 | Gas | | | |
| Heat Type | 04 | Hot Air | | | |
| AC Type | 03 | Central | | | |
| Bedrooms | 02 | 2 Bedrooms | | | |
| Full Baths | 2 | 2 Full | | | |
| Half Baths | 1 | | | | |
| Extra Fixtures | 0 | | | | |
| Total Rooms | 4 | | | | |
| Bath Style | 03 | Modern | | | |
| Kitchen Style | 04 | Typical for Gr | | | |
| Master Deed L | 1743 | | | | |
| Bath Split | 21 | 2 Full-1 Half | | | |
| Foundation | 03 | Conc. Slab | | | |
| AC Type Alt | | | | | |
| Sewer Occupan | | | | | |
| CONDO DATA | | | | | |
| Parcel Id | 105421 | C 0017 | Owne | 3.2 | |
| | FLAGSHIP ESTS | B 1 | S 1 | | |
| Adjust Type | Code | Description | Factor% | | |
| Condo Flr | | | 100 | | |
| Condo Unit | MKT0 | MKT0 | 100 | | |
| COST / MARKET VALUATION | | | | | |
| Building Value New | | 322,950 | | | |
| Year Built | | 2007 | | | |
| Effective Year Built | | 2013 | | | |
| Depreciation Code | | A | | | |
| Remodel Rating | | | | | |
| Year Remodeled | | | | | |
| Depreciation % | | 5 | | | |
| Functional Obsol | | 0 | | | |
| External Obsol | | 0 | | | |
| Trend Factor | | 1 | | | |
| Condition | | | | | |
| Condition % | | | | | |
| Percent Good | | 95 | | | |
| Cns Sect Rcnld | | 306,800 | | | |
| Dep % Ovr | | | | | |
| Dep Ovr Comment | | | | | |
| Misc Imp Ovr | | | | | |
| Misc Imp Ovr Comment | | | | | |
| Cost to Cure Ovr | | | | | |
| Cost to Cure Ovr Comment | | | | | |

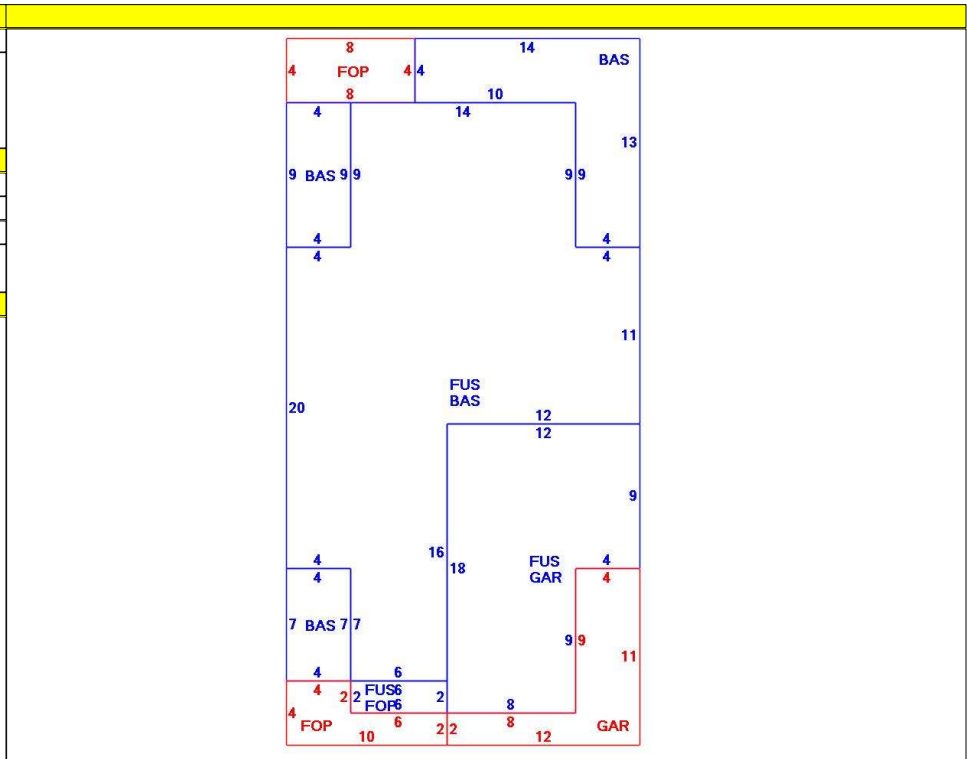

| OB - OUTBUILDING & YARD ITEMS(L) / XF - BUILDING EXTRA FEATURES(B) | | | | | | | | | | |
|--|---------------|-----|-------|------------|--------|----------|------|-------|------------|-------------|
| Code | Description | L/B | Units | Unit Price | Yr Blt | Cond. Cd | % Gd | Grade | Grade Adj. | Appr. Value |
| FOP | Open Porch-ro | B | 72 | 55.00 | 2015 | | 95 | | 0.00 | 4,200 |
| GAR | Attached Gara | B | 240 | 40.00 | 2015 | | 95 | | 0.00 | 10,800 |

| BUILDING SUB-AREA SUMMARY SECTION | | | | | | |
|-----------------------------------|-----------------|-------------|------------|----------|-----------|----------------|
| Code | Description | Living Area | Floor Area | Eff Area | Unit Cost | Undeprec Value |
| BAS | First Floor | 656 | 656 | 656 | 239.58 | 157,163 |
| FOP | Open Porch | 0 | 72 | 0 | 0.00 | 0 |
| FUS | Upper Story | 692 | 692 | 692 | 239.58 | 165,787 |
| GAR | Attached Garage | 0 | 240 | 0 | 0.00 | 0 |
| Ttl Gross Liv / Lease Area | | 1,348 | 1,660 | 1,348 | | 322,950 |

