

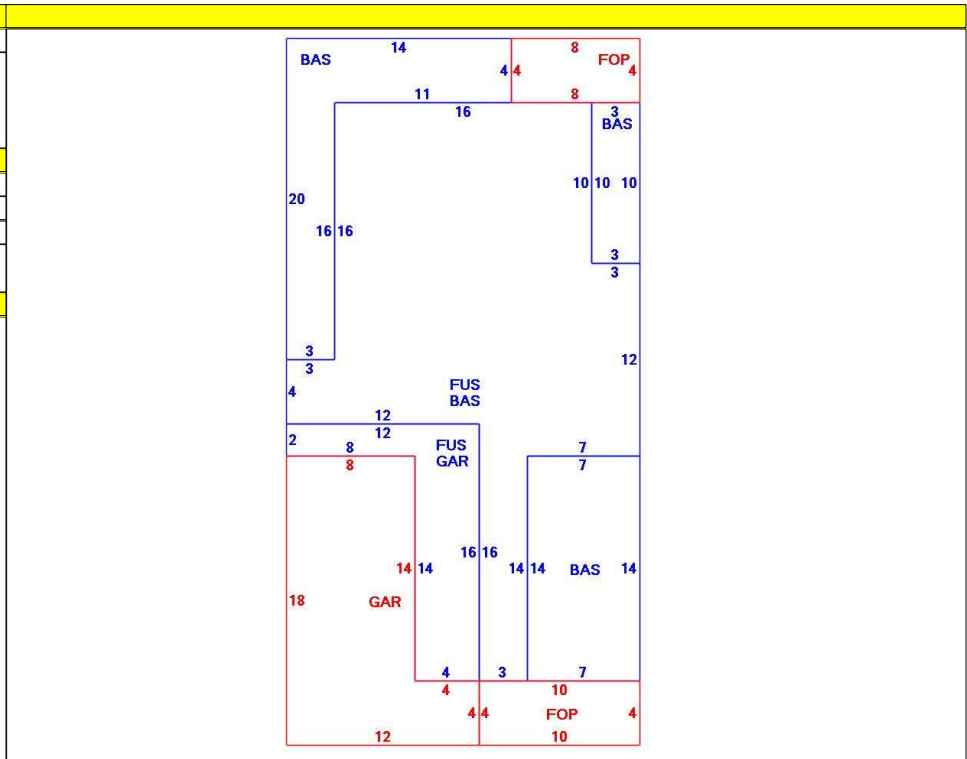

CONSTRUCTION DETAIL			CONSTRUCTION DETAIL (CONTINUED)		
Element	Cd	Description	Element	Cd	Description
Style	55	Condominium			
Model	05	Res Condo			
Bedrm Func	C	Average			
Stories	2	2 Stories			
Occupancy					
Interior Wall 1	05	Drywall			
Interior Wall 2					
Interior Floor 1	14	Carpet			
Interior Floor 2					
Heat Fuel	03	Gas			
Heat Type	04	Hot Air			
AC Type	03	Central			
Bedrooms	01	1 Bedroom			
Full Baths	1	1 Full			
Half Baths	1				
Extra Fixtures	0				
Total Rooms	3				
Bath Style	03	Modern			
Kitchen Style	04	Typical for Gr			
Master Deed L	1494				
Bath Split	11	1 Full-1 Half			
Foundation	03	Conc. Slab			
AC Type Alt					
Sewer Occupan					
<b>CONDO DATA</b>					
Parcel Id	105421	C 0017	Ownr	2.7	
	FLAGSHIP ESTS	B 1	S 1		
Adjust Type	Code	Description	Factor%		
Condo Flr			100		
Condo Unit	MKT0	MKT0	100		
<b>COST / MARKET VALUATION</b>					
Building Value New		282,807			
Year Built		2007			
Effective Year Built		2013			
Depreciation Code		A			
Remodel Rating					
Year Remodeled					
Depreciation %		5			
Functional Obsol		0			
External Obsol		0			
Trend Factor		1			
Condition					
Condition %					
Percent Good		95			
Cns Sect Rcnld		268,700			
Dep % Ovr					
Dep Ovr Comment					
Misc Imp Ovr					
Misc Imp Ovr Comment					
Cost to Cure Ovr					
Cost to Cure Ovr Comment					



**OB - OUTBUILDING & YARD ITEMS(L) / XF - BUILDING EXTRA FEATURES(B)**

Code	Description	L/B	Units	Unit Price	Yr Blt	Cond. Cd	% Gd	Grade	Grade Adj.	Appr. Value
FOP	Open Porch-ro	B	72	55.00	2015		95		0.00	4,200
GAR	Attached Gara	B	240	40.00	2015		95		0.00	10,800

**BUILDING SUB-AREA SUMMARY SECTION**

Code	Description	Living Area	Floor Area	Eff Area	Unit Cost	Undeprec Value
BAS	First Floor	656	656	656	243.80	159,932
FOP	Open Porch	0	72	0	0.00	0
FUS	Upper Story	504	504	504	243.80	122,875
GAR	Attached Garage	0	240	0	0.00	0
Ttl Gross Liv / Lease Area		1,160	1,472	1,160		282,807

