

CURRENT OWNER				TOPO	UTILITIES	STRT / ROAD	LOCATION	CURRENT ASSESSMENT					801 FY2024 BARNSTABLE, MA VISION					
1347 LLC								Description	Code	Assessed	Assessed							
1 THORNDAL CIRCLE								RESIDNTL	1020	1,041,500	1,041,500							
DARIEN CT 06820				SUPPLEMENTAL DATA			Alt Prcl ID Split Zonin BID Parcel ResExpt Q #DL 1 UNIT 3 #DL 2 BLDG A GIS ID F_975249_2695227		Plan Ref. Land Ct# 8993-B LOT 1 #SR Life Estate PP STATU Assoc Pid#		Total		1,041,500	1,041,500				
RECORD OF OWNERSHIP				BK-VOL/PAGE	SALE DATE	Q/U	V/I	SALE PRICE	VC	PREVIOUS ASSESSMENTS (HISTORY)								
1347 LLC				C382-0	09-16-2022	U	I	1,100,000	1T	Year	Code	Assessed	Year	Code	Assessed	Year	Code	Assessed
CALHOUN, HARRY C & KATHLEEN L				C382-0	05-02-2011	Q	I	725,000	00	2023	1020	1,054,100	2022	1020	1,034,500	2021	1020	754,900
TRADE WINDS DEVELOPMENT-A INC				#D112 0	08-05-2009	U	I	5,100,000	1V									
TRADE WINDS RESIDENCES LLC				C182 0	04-05-2007	U	I	5,250,000	1P									
				Total				1,054,100		Total		1,034,500	Total		754,900			
EXEMPTIONS				OTHER ASSESSMENTS				This signature acknowledges a visit by a Data Collector or Assessor										
Year	Code	Description	Amount	Code	Description	Number	Amount	Comm Int										
			Total					0.00										
ASSESSING NEIGHBORHOOD																		
Nbhd	Nbhd Name	B	Tracing	Batch														
0001				CENVIL														
NOTES																		
BUILDING PERMIT RECORD										VISIT / CHANGE HISTORY								
Permit Id	Issue Date	Type	Description	Amount	Insp Date	% Comp	Date Comp	Comments	Date	Id	Type	Is	Cd	Purpost/Result				
									05-18-2020	WD			FR	Field Review				
									12-03-2018	SR	02		03	Cycl Insp Comp				
									02-04-2016	TR	03		16	In Office Review				
									08-07-2015	TP	03		16	In Office Review				
									07-12-2013	TP	03		16	In Office Review				
									06-12-2009	TP	03		16	In Office Review				
									06-12-2008	TP	01		00	Meas/Listed-Interior Acces				
LAND LINE VALUATION SECTION																		
B	Use Code	Description	Zone	Dist	Land Type	Land Units	Unit Price	Size Adj	Site Index	Cond.	Nbhd.	Nbhd. Adj	Notes	Location Adjustmen	Adj Unit P	Land Value		
1	102U	Condominium M	CBD	3		0 SF	0.00	1.00000	5	1.00	0001	1.000			0.0000	0		
Total Card Land Units						0	SF	Parcel Total Land Area				0.00	Total Land Value				0	

CONSTRUCTION DETAIL			CONSTRUCTION DETAIL (CONTINUED)		
Element	Cd	Description	Element	Cd	Description
Style	55	Condominium			
Model	05	Res Condo			
Bedrm Func	B	Custom			
Stories	2	2 Stories			
Occupancy					
Interior Wall 1	05	Drywall			
Interior Wall 2					
Interior Floor 1	12	Hardwood			
Interior Floor 2					
Heat Fuel	03	Gas			
Heat Type	04	Hot Air			
AC Type	03	Central			
Bedrooms	02	2 Bedrooms			
Full Baths	2	2 Full			
Half Baths	2				
Extra Fixtures	2				
Total Rooms	5				
Bath Style					
Kitchen Style					
Master Deed L	2535				
Bath Split	22	2 Full-2 Half			
Foundation	01	Poured Conc.			
AC Type Alt					
Sewer Occupan					
CONDO DATA					
Parcel Id	105857	C 101	Ownr	6.4	
	TRADEWINDS	B 1	S 1		
Adjust Type	Code	Description	Factor%		
Condo Flr			100		
Condo Unit	MKT0	MKT0	100		
COST / MARKET VALUATION					
Building Value New		1,080,873			
Year Built		2007			
Effective Year Built		2013			
Depreciation Code		A			
Remodel Rating					
Year Remodeled		5			
Depreciation %					
Functional Obsol					
External Obsol					
Trend Factor		1			
Condition					
Condition %		95			
Percent Good		1,026,800			
Cns Sect Rcnld					
Dep % Ovr					
Dep Ovr Comment					
Misc Imp Ovr					
Misc Imp Ovr Comment					
Cost to Cure Ovr					
Cost to Cure Ovr Comment					

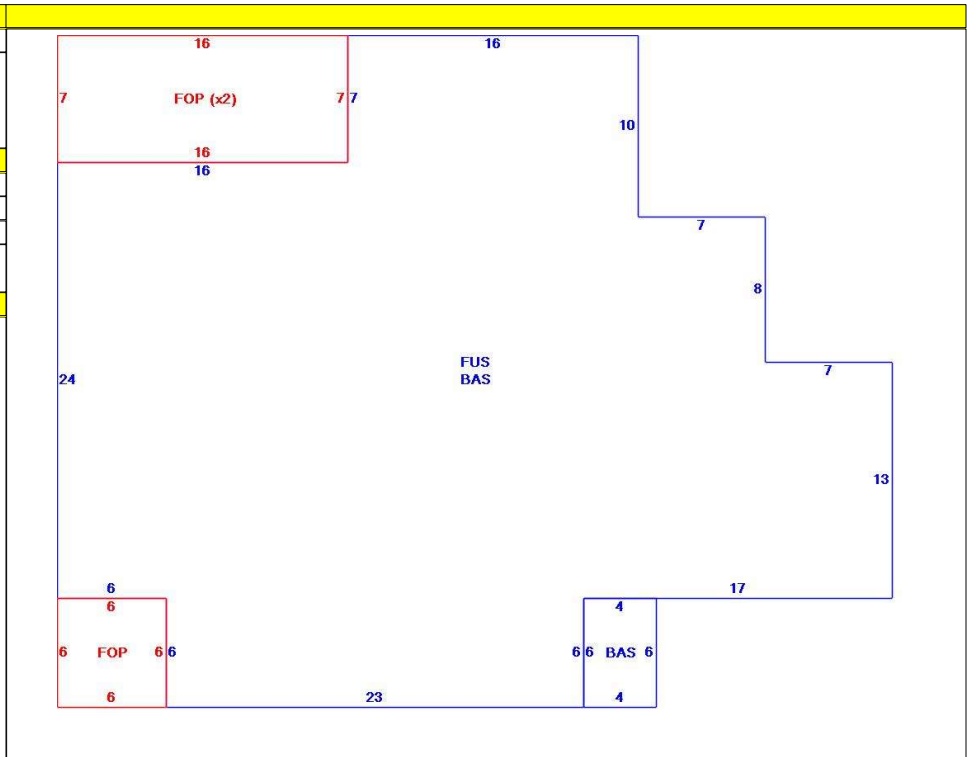

OB - OUTBUILDING & YARD ITEMS(L) / XF - BUILDING EXTRA FEATURES(B)										
Code	Description	L/B	Units	Unit Price	Yr Blt	Cond. Cd	% Gd	Grade	Grade Adj.	Appr. Value
FPLG	Gas Fireplace	B	1	2500.00	2015		95		0.00	2,400
BGAR	Bsmt Garage	B	1	2326.00	2015		95		0.00	2,200
FOP	Open Porch-ro	B	260	55.00	2015		95		0.00	10,100

BUILDING SUB-AREA SUMMARY SECTION						
Code	Description	Living Area	Floor Area	Eff Area	Unit Cost	Undeprec Value
BAS	First Floor	1,280	1,280	1,280	426.21	545,551
FOP	Open Porch	0	260	0	0.00	0
FUS	Upper Story	1,256	1,256	1,256	426.21	535,322
Ttl Gross Liv / Lease Area		2,536	2,796	2,536		1,080,873

