

CURRENT OWNER		TOPO	UTILITIES	STRT / ROAD	LOCATION	CURRENT ASSESSMENT				
WEST BARNSTABLE COMMUNITIES C/O PRESERVATION AFFORDABLE H 920 MAIN STREET SUITE 115						Description	Code	Assessed	Assessed	801 FY2024 BARNSTABLE, MA
						RESIDENTL	1120	1,932,400	1,932,400	
KANSAS CITY MO 64105						RES LAND	1120	336,000	336,000	<b>VISION</b>
						<b>SUPPLEMENTAL DATA</b>				
Alt Prcl ID Split Zonin BID Parcel ResExpt Q #DL 1 #DL 2 GIS ID F_972478_2713952				Plan Ref. Land Ct# #SR Life Estate PP STATU Assoc Pid#						

RECORD OF OWNERSHIP		BK-VOL/PAGE	SALE DATE	Q/U	V/I	SALE PRIC	VC	PREVIOUS ASSESSMENTS (HISTORY)								
WEST BARNSTABLE COMMUNITIES LP		0001 0002	04-28-2008	U	I	0	1E	Year	Code	Assessed	Year	Code	Assessed V	Year	Code	Assessed
								2023	1120	1,932,400	2022	1120	1,474,700	2021	1120	1,361,200
									1120	336,000		1120	336,000		1120	336,000
															1120	142,700
								Total		2,268,400	Total		1,810,700	Total		1,839,900

EXEMPTIONS				OTHER ASSESSMENTS				This signature acknowledges a visit by a Data Collector or Assessor											
Year	Code	Description	Amount	Code	Description	Number	Amount	Comm Int											
			Total				0.00												
<b>ASSESSING NEIGHBORHOOD</b>														<b>APPRAISED VALUE SUMMARY</b>					
Nbhd	Nbhd Name		B		Tracing		Batch		Appraised Bldg. Value (Card)						1,717,300				
CI03							WBARNS		Appraised Xf (B) Value (Bldg)						72,400				
<b>NOTES</b>														Appraised Ob (B) Value (Bldg)				142,700	
KIMBER WOODS														Appraised Land Value (Bldg)				336,000	
														Special Land Value				0	
														Total Appraised Parcel Value				2,268,400	
														Valuation Method				C	
														Total Appraised Parcel Value				2,268,400	

BUILDING PERMIT RECORD									VISIT / CHANGE HISTORY						
Permit Id	Issue Date	Type	Description	Amount	Insp Date	% Comp	Date Comp	Comments	Date	Id	Type	Is	Cd	Purpost/Result	
200902722	06-15-2009	RE	Remodel	30,000	08-14-2009	100	06-30-2010	BLD#5 BMT STORAGE AREA	04-06-2020	GM	04		FR	Field Review	
200805242	12-29-2008	CM	Commercial	48,928	06-30-2009	100	06-30-2009	4 UNITS-FITOUT	06-24-2019	CK	22		22	Change of Address	
200805227	11-27-2008	CM	Commercial	48,928	06-30-2009	100	06-30-2009	4 UNITS-FITOUT	04-07-2014	TP	22		22	Change of Address	
200805222	11-27-2008	CM	Commercial	48,928	06-30-2009	100	06-30-2009	4 UNITS-FITOUT	01-18-2013	DR	22		22	Change of Address	
200805221	11-27-2008	CM	Commercial	48,928	06-30-2009	100	06-30-2009	4 UNITS-FITOUT	10-01-2009	NF	03		52	New Construction	
200805220	11-17-2008	CM	Commercial	48,928	06-30-2009	100	06-30-2009	4 UNITS-FITOUT	08-14-2009	MK	01		52	New Construction	
200805214	11-17-2008	CM	Commercial	48,928	06-30-2009	100	06-30-2009	4 UNITS-FITOUT	08-14-2009	MK	01		52	New Construction	

LAND LINE VALUATION SECTION																
B	Use Code	Description	Zone	LA	Land Units	Unit Price	Size Adj	AC Disc	Site Index	Cond.	Nbhd.	Nbhd. Adj	Notes	Location Adjustmen	Adj Unit P	Land Value
1	1120	APTS 9+/M-07	RF	5	28 BL	12,000.00	1.00000	1.0000	0	1.00		1.000	LEASED FOR AFFORD		1.0000	12,000
1	1120	APTS 9+/M-07		5	1.000 AC	0.00	1.00000	1.0000	0	1.00		1.000	ACTUAL LOT SIZE		0.0000	0
Total Card Land Units					1.00	BL	Parcel Total Land Area					1.00	Total Land Value			336,000



CURRENT OWNER				TOPO	UTILITIES	STRT / ROAD	LOCATION	CURRENT ASSESSMENT				
WEST BARNSTABLE COMMUNITIES C/O PRESERVATION AFFORDABLE H 920 MAIN STREET SUITE 115								Description	Code	Assessed	Assessed	801 FY2024 BARNSTABLE, MA
								RESIDNTL	1120	1,932,400	1,932,400	
KANSAS CITY MO 64105								RES LAND	1120	336,000	336,000	<b>VISION</b>
								<b>SUPPLEMENTAL DATA</b>				
				Alt Prcl ID	Plan Ref.							
				Split Zonin	Land Ct#							
				BID Parcel	#SR							
				ResExpt Q	Life Estate							
				#DL 1	PP STATU							
				#DL 2	Assoc Pid#							
				GIS ID	F_972478_2713952							
								Total		2,268,400	2,268,400	

RECORD OF OWNERSHIP				BK-VOL/PAGE	SALE DATE	Q/U	V/I	SALE PRIC	VC	PREVIOUS ASSESSMENTS (HISTORY)					
WEST BARNSTABLE COMMUNITIES LP				0001 0002	04-28-2008	U	I	0	1E	Year	Code	Assessed	Year	Code	Assessed
										2023	1120	1,932,400	2022	1120	1,474,700
											1120	336,000		1120	336,000
													2021	1120	142,700
														1120	142,700
										Total	2,268,400	Total	1,810,700	Total	1,839,900

EXEMPTIONS				OTHER ASSESSMENTS				APPRAISED VALUE SUMMARY				
Year	Code	Description	Amount	Code	Description	Number	Amount	Comm Int	This signature acknowledges a visit by a Data Collector or Assessor			
									Appraised Bldg. Value (Card) 1,717,300			
									Appraised Xf (B) Value (Bldg) 72,400			
									Appraised Ob (B) Value (Bldg) 142,700			
									Appraised Land Value (Bldg) 336,000			
									Special Land Value 0			
									Total Appraised Parcel Value 2,268,400			
									Valuation Method C			
									Total Appraised Parcel Value 2,268,400			

ASSESSING NEIGHBORHOOD			
Nbhd	Nbhd Name	B	Tracing
CI03			WBARNS

NOTES			

BUILDING PERMIT RECORD										VISIT / CHANGE HISTORY					
Permit Id	Issue Date	Type	Description	Amount	Insp Date	% Comp	Date Comp	Comments		Date	Id	Type	Is	Cd	Purpost/Result

LAND LINE VALUATION SECTION																	
B	Use Code	Description	Zone	LA	Land Units	Unit Price	Size Adj	AC Disc	Site Index	Cond.	Nbhd.	Nbhd. Adj	Notes	Location Adjustmen	Adj Unit P	Land Value	
2	1120	APTS 9+/M-07	RF	5	0 SF	0.00	1.00000	1.0000	5	1.00	CI03	0.500	BLD2	0.0000	0	0	
Total Card Land Units					0.00	SF	Parcel Total Land Area					1.00	Total Land Value				0



CURRENT OWNER				TOPO	UTILITIES	STRT / ROAD	LOCATION	CURRENT ASSESSMENT				
WEST BARNSTABLE COMMUNITIES C/O PRESERVATION AFFORDABLE H 920 MAIN STREET SUITE 115								Description	Code	Assessed	Assessed	801 FY2024 BARNSTABLE, MA
								RESIDNTL	1120	1,932,400	1,932,400	
KANSAS CITY MO 64105				<b>SUPPLEMENTAL DATA</b>				RES LAND	1120	336,000	336,000	<b>VISION</b>
				Alt Prcl ID Split Zonin BID Parcel ResExpt Q #DL 1 #DL 2 GIS ID F_972478_2713952	Plan Ref. Land Ct# #SR Life Estate PP STATU Assoc Pid#							
								Total		2,268,400	2,268,400	

RECORD OF OWNERSHIP				BK-VOL/PAGE	SALE DATE	Q/U	V/I	SALE PRIC	VC	PREVIOUS ASSESSMENTS (HISTORY)								
WEST BARNSTABLE COMMUNITIES LP				0001 0002	04-28-2008	U	I	0	1E	Year	Code	Assessed	Year	Code	Assessed V	Year	Code	Assessed
										2023	1120	1,932,400	2022	1120	1,474,700	2021	1120	1,361,200
											1120	336,000		1120	336,000		1120	336,000
																	1120	142,700
										Total	2,268,400	Total	1,810,700	Total	1,839,900			

EXEMPTIONS				OTHER ASSESSMENTS				This signature acknowledges a visit by a Data Collector or Assessor												
Year	Code	Description	Amount	Code	Description	Number	Amount	Comm Int												
			Total	0.00																
ASSESSING NEIGHBORHOOD												APPRAISED VALUE SUMMARY								
Nbhd	Nbhd Name			B	Tracing			Batch												
CI03								WBARNS												
NOTES												Appraised Bldg. Value (Card)						1,717,300		
												Appraised Xf (B) Value (Bldg)						72,400		
												Appraised Ob (B) Value (Bldg)						142,700		
												Appraised Land Value (Bldg)						336,000		
												Special Land Value						0		
												Total Appraised Parcel Value						2,268,400		
												Valuation Method						C		
												Total Appraised Parcel Value						2,268,400		

BUILDING PERMIT RECORD												VISIT / CHANGE HISTORY					
Permit Id	Issue Date	Type	Description	Amount	Insp Date	% Comp	Date Comp	Comments	Date	Id	Type	Is	Cd	Purpost/Result			

LAND LINE VALUATION SECTION																	
B	Use Code	Description	Zone	LA	Land Units	Unit Price	Size Adj	AC Disc	Site Index	Cond.	Nbhd.	Nbhd. Adj	Notes	Location Adjustmen	Adj Unit P	Land Value	
3	1120	APTS 9+/M-07	RF	5	0 SF	0.00	1.00000	1.0000	5	1.00	CI03	0.500	BLD3	0.0000	0	0	
Total Card Land Units					0.00	SF	Parcel Total Land Area					1.00	Total Land Value				0

CONSTRUCTION DETAIL			CONSTRUCTION DETAIL (CONTINUED)		
Element	Cd	Description	Element	Cd	Description
Style	14S	Apts Com smaller			
Model	07	Apartments			
Grade:	C-	Average Minus			
Stories	2	2 Stories			
Exterior Wall 1	14	Wood Shingle			
Exterior Wall 2	11	Clapboard			
RooF Structure	03	Gable/Hip			
RooF Cover	03	Asph/F Gls/Cmp			
Interior Wall 1	05	Drywall			
Interior Wall 2					
Interior Floor 1	12	Hardwood			
Interior Floor 2					
Heat Fuel	03	Gas			
Heat Type	04	Hot Air			
AC Type	03	Central			
Bedrooms	10	10 Bedrooms			
Full Baths	6				
Half Baths	0				
Extra Fixtures					
Total Rooms					
Bath Style					
Kitchen Style					
Occupancy					
Usrflid 105					
Accessory Apt					
Foundation Alt	03	Conc. Slab			
Rms Prts					
Bath Split	60	6 Full-0 Half			

CONDO DATA			
Parcel Id		C	Owne 0.0
		B	S
Adjust Type	Code	Description	Factor%
Condo Flr			
Condo Unit			

COST / MARKET VALUATION	
Building Value New	577,574
Year Built	2008
Effective Year Built	2010
Depreciation Code	A
Remodel Rating	
Year Remodeled	
Depreciation %	7
Functional Obsol	
External Obsol	55
Trend Factor	1
Condition	
Condition %	
Percent Good	38
RCNLD	219,500
Dep % Ovr	
Dep Ovr Comment	
Misc Imp Ovr	
Misc Imp Ovr Comment	
Cost to Cure Ovr	
Cost to Cure Ovr Comment	

**OB - OUTBUILDING & YARD ITEMS(L) / XF - BUILDING EXTRA FEATURES(B)**

Code	Description	L/B	Units	Unit Price	Yr Blt	Cond. Cd	% Gd	Grade	Grade Adj.	Appr. Value
WDC	Wood Decking	L	400	20.00	2010		82		0.00	6,300
FOP	Open Porch-ro	B	432	55.00	2012		38		0.00	6,400

**BUILDING SUB-AREA SUMMARY SECTION**

Code	Description	Living Area	Floor Area	Eff Area	Unit Cost	Undeprec Value
BAS	First Floor	3,008	3,008	3,008	112.08	337,151
FOP	Open Porch	0	432	65	16.86	7,286
FUS	Upper Story	2,168	2,168	2,060	106.50	230,895
WDK	Wood Deck	0	400	20	5.60	2,242
Ttl Gross Liv / Lease Area		5,176	6,008	5,153		577,574

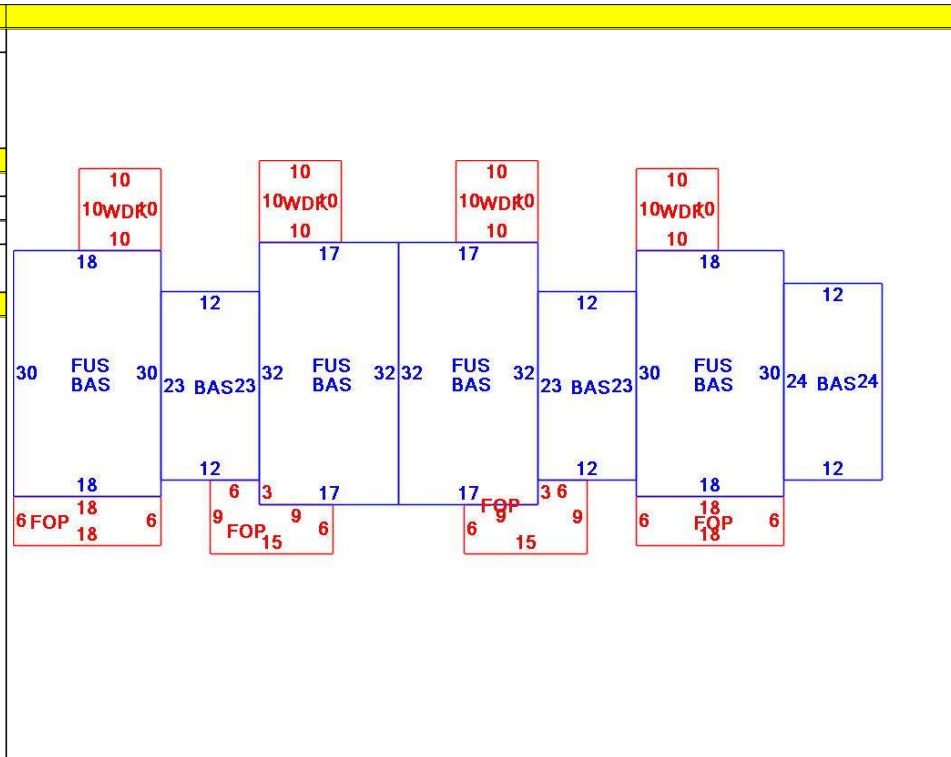







CURRENT OWNER		TOPO	UTILITIES	STRT / ROAD	LOCATION	CURRENT ASSESSMENT				
WEST BARNSTABLE COMMUNITIES C/O PRESERVATION AFFORDABLE H 920 MAIN STREET SUITE 115						Description	Code	Assessed	Assessed	801 FY2024 BARNSTABLE, MA
KANSAS CITY MO 64105						RESIDNTL	1120	1,932,400	1,932,400	
						RES LAND	1120	336,000	336,000	<b>VISION</b>
SUPPLEMENTAL DATA						Total				
Alt Prcl ID Split Zonin BID Parcel ResExpt Q #DL 1 #DL 2 GIS ID F_972478_2713952				Plan Ref. Land Ct# #SR Life Estate PP STATU Assoc Pid#		2,268,400 2,268,400				

RECORD OF OWNERSHIP		BK-VOL/PAGE		SALE DATE	Q/U	V/I	SALE PRIC	VC	PREVIOUS ASSESSMENTS (HISTORY)								
WEST BARNSTABLE COMMUNITIES LP		0001	0002	04-28-2008	U	I	0	1E	Year	Code	Assessed	Year	Code	Assessed V	Year	Code	Assessed
									2023	1120	1,932,400	2022	1120	1,474,700	2021	1120	1,361,200
										1120	336,000		1120	336,000		1120	336,000
																1120	142,700
									Total		2,268,400	Total		1,810,700	Total		1,839,900

EXEMPTIONS				OTHER ASSESSMENTS				This signature acknowledges a visit by a Data Collector or Assessor										
Year	Code	Description	Amount	Code	Description	Number	Amount	Comm Int										
			Total				0.00											

ASSESSING NEIGHBORHOOD						APPRAISED VALUE SUMMARY						
Nbhd	Nbhd Name		B	Tracing		Batch	Appraised Bldg. Value (Card)					1,717,300
CI03						WBARNS	Appraised Xf (B) Value (Bldg)					72,400
						Appraised Ob (B) Value (Bldg)					142,700	
						Appraised Land Value (Bldg)					336,000	
						Special Land Value					0	
						Total Appraised Parcel Value					2,268,400	
						Valuation Method					C	
						Total Appraised Parcel Value					2,268,400	

BUILDING PERMIT RECORD											VISIT / CHANGE HISTORY					
Permit Id	Issue Date	Type	Description	Amount	Insp Date	% Comp	Date Comp	Comments			Date	Id	Type	Is	Cd	Purpost/Result

LAND LINE VALUATION SECTION																	
B	Use Code	Description	Zone	LA	Land Units	Unit Price	Size Adj	AC Disc	Site Index	Cond.	Nbhd.	Nbhd. Adj	Notes	Location Adjustmen	Adj Unit P	Land Value	
5	1120	APTS 9+/M-07	RF	5	0 SF	0.00	1.00000	1.0000	5	1.00	CI03	0.500	BLD5	0.0000	0	0	
Total Card Land Units					0.00	SF	Parcel Total Land Area					1.00	Total Land Value				0



CURRENT OWNER				TOPO	UTILITIES	STRT / ROAD	LOCATION	CURRENT ASSESSMENT				
WEST BARNSTABLE COMMUNITIES C/O PRESERVATION AFFORDABLE H 920 MAIN STREET SUITE 115								Description	Code	Assessed	Assessed	801 FY2024 BARNSTABLE, MA
								RESIDNTL	1120	1,932,400	1,932,400	
KANSAS CITY MO 64105								RES LAND	1120	336,000	336,000	<b>VISION</b>
								<b>SUPPLEMENTAL DATA</b>				
				Alt Prcl ID	Plan Ref.							
				Split Zonin	Land Ct#							
				BID Parcel	#SR							
				ResExpt Q	Life Estate							
				#DL 1	PP STATU							
				#DL 2	Assoc Pid#							
				GIS ID	F_972478_2713952							
								Total		2,268,400	2,268,400	

RECORD OF OWNERSHIP				BK-VOL/PAGE	SALE DATE	Q/U	V/I	SALE PRIC	VC	PREVIOUS ASSESSMENTS (HISTORY)					
WEST BARNSTABLE COMMUNITIES LP				0001 0002	04-28-2008	U	I	0	1E	Year	Code	Assessed	Year	Code	Assessed
										2023	1120	1,932,400	2022	1120	1,474,700
											1120	336,000		1120	336,000
													2021	1120	142,700
														1120	142,700
										Total		2,268,400	Total		1,810,700
										Total			Total		1,839,900

EXEMPTIONS				OTHER ASSESSMENTS				This signature acknowledges a visit by a Data Collector or Assessor				
Year	Code	Description	Amount	Code	Description	Number	Amount	Comm Int				
			Total				0.00					

ASSESSING NEIGHBORHOOD				APPRAISED VALUE SUMMARY					
Nbhd	Nbhd Name		B	Tracing		Batch		Appraised Bldg. Value (Card)	1,717,300
CI03				WBARNS				Appraised Xf (B) Value (Bldg)	72,400
								Appraised Ob (B) Value (Bldg)	142,700
								Appraised Land Value (Bldg)	336,000
								Special Land Value	0
								Total Appraised Parcel Value	2,268,400
								Valuation Method	C
								Total Appraised Parcel Value	2,268,400

BUILDING PERMIT RECORD										VISIT / CHANGE HISTORY					
Permit Id	Issue Date	Type	Description	Amount	Insp Date	% Comp	Date Comp	Comments		Date	Id	Type	Is	Cd	Purpost/Result

LAND LINE VALUATION SECTION																	
B	Use Code	Description	Zone	LA	Land Units	Unit Price	Size Adj	AC Disc	Site Index	Cond.	Nbhd.	Nbhd. Adj	Notes	Location Adjustmen	Adj Unit P	Land Value	
6	1120	APTS 9+/M-07	RF	5	0 SF	0.00	1.00000	1.0000	5	1.00	CI03	0.500	BLD6	0.0000	0	0	
					Total Card Land Units	0.00	SF	Parcel Total Land Area			1.00					Total Land Value	0

CONSTRUCTION DETAIL			CONSTRUCTION DETAIL (CONTINUED)		
Element	Cd	Description	Element	Cd	Description
Style	14S	Apts Com smaller			
Model	07	Apartments			
Grade:	C-	Average Minus			
Stories	2	2 Stories			
Exterior Wall 1	14	Wood Shingle			
Exterior Wall 2	11	Clapboard			
RooF Structure	03	Gable/Hip			
RooF Cover	03	Asph/F Gls/Cmp			
Interior Wall 1	05	Drywall			
Interior Wall 2					
Interior Floor 1	12	Hardwood			
Interior Floor 2					
Heat Fuel	03	Gas			
Heat Type	04	Hot Air			
AC Type	03	Central			
Bedrooms	10	10 Bedrooms			
Full Baths	6				
Half Baths	0				
Extra Fixtures					
Total Rooms					
Bath Style					
Kitchen Style					
Occupancy					
Usrflid 105					
Accessory Apt					
Foundation Alt	03	Conc. Slab			
Rms Prts					
Bath Split	60	6 Full-0 Half			

CONDO DATA			
Parcel Id		C	Owne 0.0
		B	S
Adjust Type	Code	Description	Factor%
Condo Flr			
Condo Unit			

COST / MARKET VALUATION	
Building Value New	551,490
Year Built	2008
Effective Year Built	2010
Depreciation Code	A
Remodel Rating	
Year Remodeled	
Depreciation %	7
Functional Obsol	
External Obsol	55
Trend Factor	1
Condition	
Condition %	
Percent Good	38
RCNLD	209,600
Dep % Ovr	
Dep Ovr Comment	
Misc Imp Ovr	
Misc Imp Ovr Comment	
Cost to Cure Ovr	
Cost to Cure Ovr Comment	

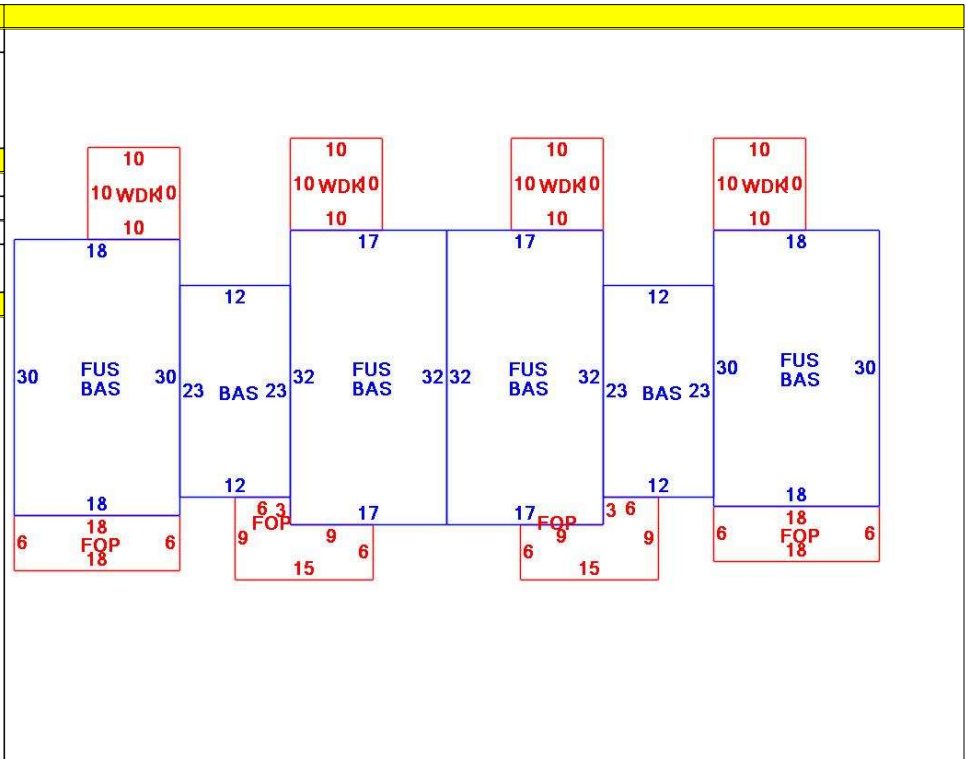

OB - OUTBUILDING & YARD ITEMS(L) / XF - BUILDING EXTRA FEATURES(B)										
Code	Description	L/B	Units	Unit Price	Yr Blt	Cond. Cd	% Gd	Grade	Grade Adj.	Appr. Value
WDC	Wood Decking	L	400	20.00	2010		82		0.00	6,300
FOP	Open Porch-ro	B	432	55.00	2012		38		0.00	6,400

BUILDING SUB-AREA SUMMARY SECTION						
Code	Description	Living Area	Floor Area	Eff Area	Unit Cost	Undeprec Value
BAS	First Floor	2,720	2,720	2,720	113.36	308,335
FOP	Open Porch	0	432	65	17.06	7,368
FUS	Upper Story	2,168	2,168	2,060	107.71	233,519
WDK	Wood Deck	0	400	20	5.67	2,267
Ttl Gross Liv / Lease Area		4,888	5,720	4,865		551,489



CURRENT OWNER				TOPO	UTILITIES	STRT / ROAD	LOCATION	CURRENT ASSESSMENT				
WEST BARNSTABLE COMMUNITIES C/O PRESERVATION AFFORDABLE H 920 MAIN STREET SUITE 115								Description	Code	Assessed	Assessed	801 FY2024 BARNSTABLE, MA
								RESIDNTL	1120	1,932,400	1,932,400	
KANSAS CITY MO 64105								RES LAND	1120	336,000	336,000	<b>VISION</b>
								<b>SUPPLEMENTAL DATA</b>				
				Alt Prcl ID	Plan Ref.							
				Split Zonin	Land Ct#							
				BID Parcel	#SR							
				ResExpt Q	Life Estate							
				#DL 1	PP STATU							
				#DL 2	Assoc Pid#							
				GIS ID	F_972478_2713952							
								Total	2,268,400	2,268,400		

RECORD OF OWNERSHIP				BK-VOL/PAGE	SALE DATE	Q/U	V/I	SALE PRIC	VC	PREVIOUS ASSESSMENTS (HISTORY)								
WEST BARNSTABLE COMMUNITIES LP				0001 0002	04-28-2008	U	I	0	1E	Year	Code	Assessed	Year	Code	Assessed V	Year	Code	Assessed
										2023	1120	1,932,400	2022	1120	1,474,700	2021	1120	1,361,200
											1120	336,000		1120	336,000		1120	336,000
																	1120	142,700
										Total		2,268,400	Total		1,810,700	Total		1,839,900

EXEMPTIONS				OTHER ASSESSMENTS				This signature acknowledges a visit by a Data Collector or Assessor												
Year	Code	Description	Amount	Code	Description	Number	Amount	Comm Int												
			Total	0.00																

ASSESSING NEIGHBORHOOD				APPRAISED VALUE SUMMARY													
Nbhd	Nbhd Name			B	Tracing			Batch			Appraised Bldg. Value (Card)						1,717,300
CI03								WBARNS			Appraised Xf (B) Value (Bldg)						72,400
										Appraised Ob (B) Value (Bldg)						142,700	
										Appraised Land Value (Bldg)						336,000	
										Special Land Value						0	
										Total Appraised Parcel Value						2,268,400	
										Valuation Method						C	
										Total Appraised Parcel Value						2,268,400	

BUILDING PERMIT RECORD										VISIT / CHANGE HISTORY							
Permit Id	Issue Date	Type	Description	Amount	Insp Date	% Comp	Date Comp	Comments		Date	Id	Type	Is	Cd	Purpost/Result		

LAND LINE VALUATION SECTION																		
B	Use Code	Description	Zone	LA	Land Units	Unit Price	Size Adj	AC Disc	Site Index	Cond.	Nbhd.	Nbhd. Adj	Notes		Location Adjustmen	Adj Unit P	Land Value	
7	1120	APTS 9+/M-07	RF	5	0 SF	0.00	1.00000	1.0000	5	1.00	CI03	0.500	BLD7		0.0000	0	0	
Total Card Land Units					0.00	SF	Parcel Total Land Area					1.00	Total Land Value					0

