

CURRENT OWNER				TOPO	UTILITIES	STRT / ROAD	LOCATION	CURRENT ASSESSMENT				
HALL JR, BRERETON TR H BRERETON HALL JR FAM TRUST 58 FEATHERBED LANE								Description	Code	Assessed	Assessed	801 FY2024 BARNSTABLE, MA
								RESIDNTL	1020	243,400	243,400	
SOUTH HERO VT 05486				<b>SUPPLEMENTAL DATA</b>				Total		243,400	243,400	<b>VISION</b>
				Alt Prcl ID	Split Zonin	BID Parcel	ResExpt Q	#DL 1	UNIT E-3 (FKA 19)	Plan Ref.	504/21-23	
				#DL 2	BLDG E (FKA 5)	GIS ID	F_981148_2705820	Assoc Pid#				

RECORD OF OWNERSHIP				BK-VOL/PAGE	SALE DATE	Q/U	V/I	SALE PRICE	VC	PREVIOUS ASSESSMENTS (HISTORY)									
HALL JR, BRERETON TR JATHAS, GEORGE A & GABRIELLE E TRS LIVING INDEPENDENTLY FOREVER INC				31407	0003	07-17-2018	Q	I	140,000	00	Year	Code	Assessed	Year	Code	Assessed			
				28268	0001	07-17-2014	U	I	146,172	1K	2023	1020	200,700	2022	1020	179,400	2021	1020	178,400
				8452	0112	02-22-1993	U	V	100	1K	Total		200,700	Total		179,400	Total		181,300

EXEMPTIONS				OTHER ASSESSMENTS				
Year	Code	Description	Amount	Code	Description	Number	Amount	Comm Int
			Total					0.00

ASSESSING NEIGHBORHOOD				
Nbhd	Nbhd Name	B	Tracing	Batch
0001				HYAN

NOTES			
This signature acknowledges a visit by a Data Collector or Assessor			

  

APPRAISED VALUE SUMMARY			
Appraised Bldg. Value (Card)	240,500		
Appraised Xf (B) Value (Bldg)	0		
Appraised Ob (B) Value (Bldg)	2,900		
Appraised Land Value (Bldg)	0		
Special Land Value	0		
Total Appraised Parcel Value	243,400		
Valuation Method	C		
Total Appraised Parcel Value	243,400		

BUILDING PERMIT RECORD								VISIT / CHANGE HISTORY						
Permit Id	Issue Date	Type	Description	Amount	Insp Date	% Comp	Date Comp	Comments	Date	Id	Type	Is	Cd	Purpost/Result
201307806	10-31-2013	CND	Condominium	40,000	06-30-2014	100	06-30-2014	BLDG E UNIT 3 FIT OUT	04-27-2020	WD			FR	Field Review
									12-12-2018	SR	02		03	Cycl Insp Comp
									03-26-2015	TP	03		16	In Office Review
									12-11-2014	TP	03		16	In Office Review
									02-25-2014	NF	03		16	In Office Review
									12-11-2013	TP	03		16	In Office Review

LAND LINE VALUATION SECTION																		
B	Use Code	Description	Zone	Dist	Land Type	Land Units	Unit Price	Size Adj	Site Index	Cond.	Nbhd.	Nbhd. Adj	Notes	Location Adjustmen	Adj Unit P	Land Value		
1	102U	Condominium M	RC-	4		0 SF	0.00	1.00000	5	1.00	0001	1.000		0.0000	0	0		
Total Card Land Units						0	SF	Parcel Total Land Area						0.00	Total Land Value			0

CONSTRUCTION DETAIL			CONSTRUCTION DETAIL (CONTINUED)		
Element	Cd	Description	Element	Cd	Description
Style	55	Condominium			
Model	05	Res Condo			
Bedrm Func	C	Average			
Stories	1	1 Story			
Occupancy	0				
Interior Wall 1	05	Drywall			
Interior Wall 2					
Interior Floor 1	14	Carpet			
Interior Floor 2	05	Vinyl/Asphalt			
Heat Fuel	03	Gas			
Heat Type	04	Hot Air			
AC Type	03	Central			
Bedrooms	01	1 Bedroom			
Full Baths	1	1 Full			
Half Baths	0				
Extra Fixtures					
Total Rooms	3				
Bath Style					
Kitchen Style					
Master Deed L	918				
Bath Split	10	1 Full-0 Half			
Foundation	01	Poured Conc.			
AC Type Alt					
Sewer Occupan					
<b>CONDO DATA</b>					
Parcel Id	104295	C 0840	Ownr	3.9	
	LIVING INDEPEN	B 1	S 1		
Adjust Type	Code	Description	Factor%		
Condo Flr			100		
Condo Unit	130	130	130		
<b>COST / MARKET VALUATION</b>					
Building Value New		245,372			
Year Built		2013			
Effective Year Built		2016			
Depreciation Code		A			
Remodel Rating					
Year Remodeled					
Depreciation %		2			
Functional Obsol		0			
External Obsol		0			
Trend Factor		1			
Condition					
Condition %					
Percent Good		98			
Cns Sect Rcnld		240,500			
Dep % Ovr					
Dep Ovr Comment					
Misc Imp Ovr					
Misc Imp Ovr Comment					
Cost to Cure Ovr					
Cost to Cure Ovr Comment					

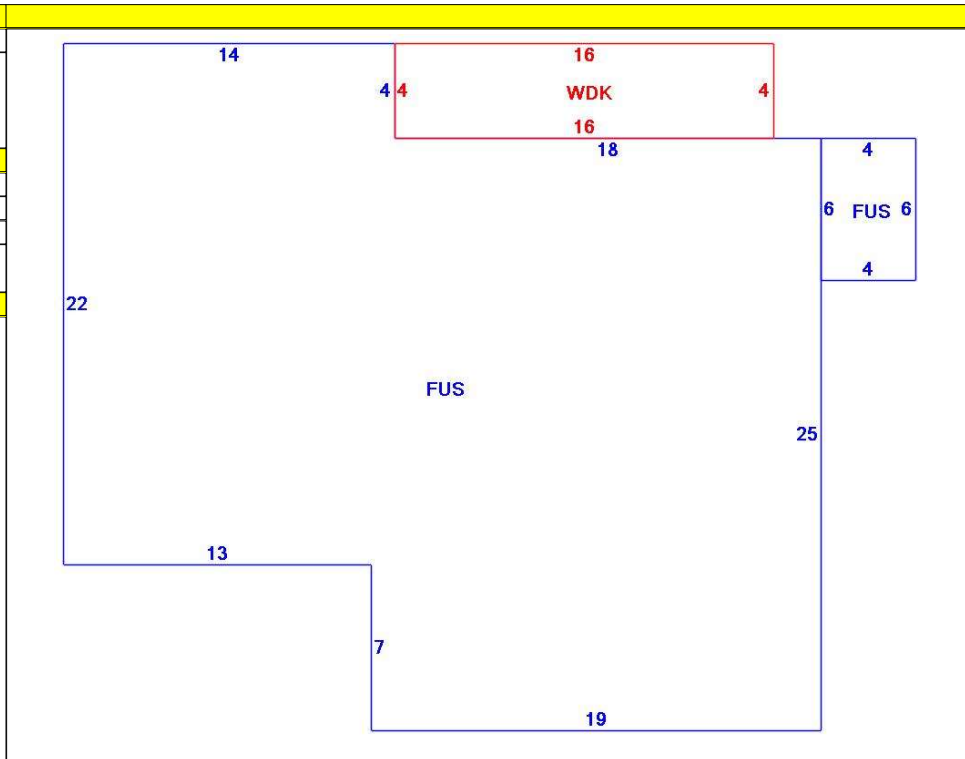

OB - OUTBUILDING & YARD ITEMS(L) / XF - BUILDING EXTRA FEATURES(B)										
Code	Description	L/B	Units	Unit Price	Yr Blt	Cond. Cd	% Gd	Grade	Grade Adj.	Appr. Value
WDC	Wood Decking	L	64	20.00	2014		90		0.00	2,900

BUILDING SUB-AREA SUMMARY SECTION						
Code	Description	Living Area	Floor Area	Eff Area	Unit Cost	Undeprec Value
FUS	Upper Story	789	789	789	310.99	245,371
WDC	Wood Deck	0	64	0	0.00	0
Ttl Gross Liv / Lease Area		789	853	789		245,371

