

CURRENT OWNER		TOPO	UTILITIES	STRT / ROAD	LOCATION	CURRENT ASSESSMENT				
SILVERSTEIN, KENNETH A & REBEC JULIE RACHEL SILVERSTEIN 09 SP 5 CASTLE LANDING						Description	Code	Assessed	Assessed	801 FY2024 BARNSTABLE, MA
RYE BROOK NY 10573						RESIDNTL	1020	243,400	243,400	
<b>SUPPLEMENTAL DATA</b>										
Alt Prcl ID Split Zonin BID Parcel ResExpt Q #DL 1 UNIT E-4 (FKA 20) #DL 2 BLDG E (FKA 5) GIS ID F_981148_2705820				Plan Ref. 504/21-23 Land Ct# #SR Life Estate PP STATU Assoc Pid#						
						Total		243,400	243,400	<b>VISION</b>

RECORD OF OWNERSHIP		BK-VOL/PAGE	SALE DATE	Q/U	V/I	SALE PRICE	VC	PREVIOUS ASSESSMENTS (HISTORY)									
SILVERSTEIN, KENNETH A & REBECCA B T LIVING INDEPENDENTLY FOREVER INC		28254 8452	0095 0112	07-09-2014 02-22-1993	U U	I V	144,629 100	1K 1K	Year	Code	Assessed	Year	Code	Assessed V	Year	Code	Assessed
									2023	1020	200,700	2022	1020	179,400	2021	1020 1020	178,400 2,900
									Total		200,700	Total		179,400	Total		181,300

EXEMPTIONS				OTHER ASSESSMENTS				This signature acknowledges a visit by a Data Collector or Assessor										
Year	Code	Description	Amount	Code	Description	Number	Amount	Comm Int										
			Total				0.00											
<b>ASSESSING NEIGHBORHOOD</b>								<b>APPRAISED VALUE SUMMARY</b>										
Nbhd	Nbhd Name		B		Tracing		Batch											
0001							HYAN											
<b>NOTES</b>																		
								Appraised Bldg. Value (Card) 240,500 Appraised Xf (B) Value (Bldg) 0 Appraised Ob (B) Value (Bldg) 2,900 Appraised Land Value (Bldg) 0 Special Land Value 0 Total Appraised Parcel Value 243,400 Valuation Method C Total Appraised Parcel Value 243,400										

BUILDING PERMIT RECORD									VISIT / CHANGE HISTORY						
Permit Id	Issue Date	Type	Description	Amount	Insp Date	% Comp	Date Comp	Comments	Date	Id	Type	Is	Cd	Purpost/Result	
201307809	10-31-2013	CND	Condominium	40,000	06-30-2014	100	06-30-2014	BLDG E UNIT 4 FIT OUT	04-27-2020	WD			FR	Field Review	
									12-12-2018	SR	02		03	Cycl Insp Comp	
									03-26-2015	TP	03		16	In Office Review	
									12-11-2014	TP	03		16	In Office Review	
									02-25-2014	NF	03		16	In Office Review	
									12-11-2013	TP	03		16	In Office Review	

LAND LINE VALUATION SECTION																			
B	Use Code	Description	Zone	Dist	Land Type	Land Units	Unit Price	Size Adj	Site Index	Cond.	Nbhd.	Nbhd. Adj	Notes	Location Adjustmen	Adj Unit P	Land Value			
1	102U	Condominium M	RC-	4		0 SF	0.00	1.00000	5	1.00	0001	1.000			0.0000	0			
Total Card Land Units						0	SF	Parcel Total Land Area						0.00	Total Land Value				0

CONSTRUCTION DETAIL			CONSTRUCTION DETAIL (CONTINUED)		
Element	Cd	Description	Element	Cd	Description
Style	55	Condominium			
Model	05	Res Condo			
Bedrm Func	C	Average			
Stories	1	1 Story			
Occupancy	0				
Interior Wall 1	05	Drywall			
Interior Wall 2					
Interior Floor 1	14	Carpet			
Interior Floor 2	05	Vinyl/Asphalt			
Heat Fuel	03	Gas			
Heat Type	04	Hot Air			
AC Type	03	Central			
Bedrooms	01	1 Bedroom			
Full Baths	1	1 Full			
Half Baths	0				
Extra Fixtures					
Total Rooms	3				
Bath Style					
Kitchen Style					
Master Deed L	918				
Bath Split	10	1 Full-0 Half			
Foundation	01	Poured Conc.			
AC Type Alt					
Sewer Occupan					
<b>CONDO DATA</b>					
Parcel Id	104295	C 0840	Owne	3.9	
	LIVING INDEPEN	B 1	S 1		
Adjust Type	Code	Description	Factor%		
Condo Flr			100		
Condo Unit	130	130	130		
<b>COST / MARKET VALUATION</b>					
Building Value New		245,372			
Year Built		2013			
Effective Year Built		2016			
Depreciation Code		A			
Remodel Rating					
Year Remodeled					
Depreciation %		2			
Functional Obsol		0			
External Obsol		0			
Trend Factor		1			
Condition					
Condition %					
Percent Good		98			
Cns Sect Rcnld		240,500			
Dep % Ovr					
Dep Ovr Comment					
Misc Imp Ovr					
Misc Imp Ovr Comment					
Cost to Cure Ovr					
Cost to Cure Ovr Comment					

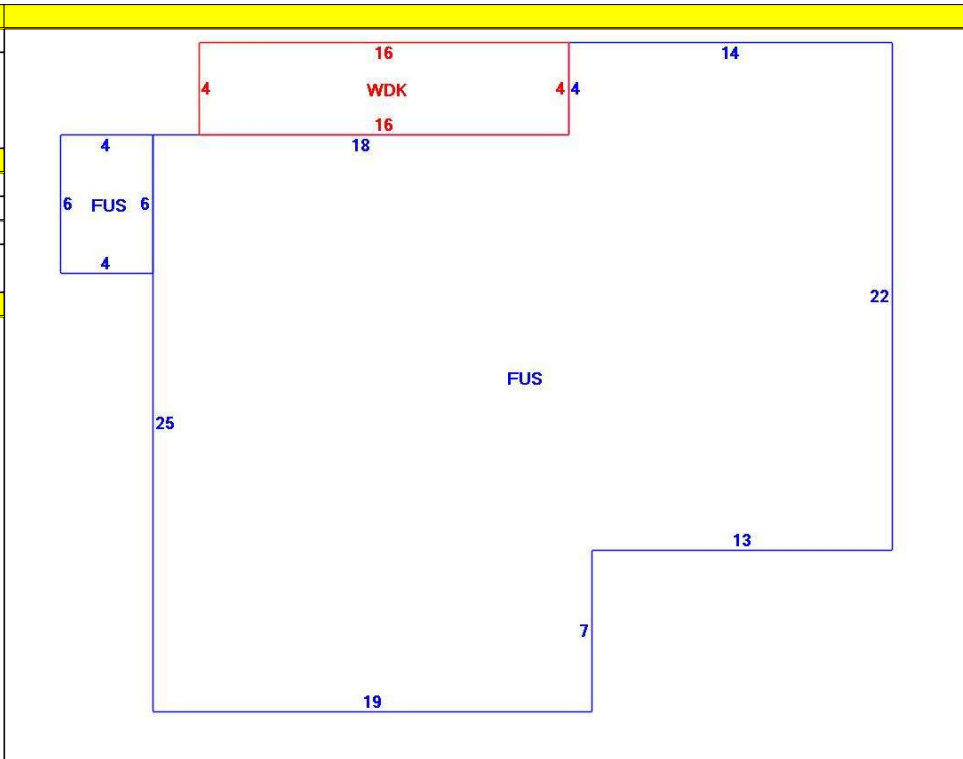

OB - OUTBUILDING & YARD ITEMS(L) / XF - BUILDING EXTRA FEATURES(B)										
Code	Description	L/B	Units	Unit Price	Yr Blt	Cond. Cd	% Gd	Grade	Grade Adj.	Appr. Value
WDC	Wood Decking	L	64	20.00	2014		90		0.00	2,900

BUILDING SUB-AREA SUMMARY SECTION						
Code	Description	Living Area	Floor Area	Eff Area	Unit Cost	Undeprec Value
FUS	Upper Story	789	789	789	310.99	245,371
WDK	Wood Deck	0	64	0	0.00	0
Ttl Gross Liv / Lease Area		789	853	789		245,371

