

CURRENT OWNER		TOPO	UTILITIES	STRT / ROAD	LOCATION	CURRENT ASSESSMENT															
FLAGSHIP ESTATES HYANNIS LLC C/O CONDYNE 100 GRANDVIEW ROAD SUITE 312 BRAINTREE MA 02184						Description		Code		Assessed		Assessed		801 FY2024 BARNSTABLE, MA <h1 style="text-align: center;">VISION</h1>							
						LND		102U		0		0									
SUPPLEMENTAL DATA						Total		0		0											
Alt Prcl ID		Split Zonin		Plan Ref. 608/35		Land Ct#		#SR		Life Estate		PP STATU									
ResExpt Q		#DL 1		UNIT E2		BLDG E		GIS ID		F_985734_2699537		Assoc Pid#									
RECORD OF OWNERSHIP			BK-VOL/PAGE	SALE DATE	Q/U	V/I	SALE PRICE	VC	PREVIOUS ASSESSMENTS (HISTORY)												
FLAGSHIP ESTATES HYANNIS LLC			21472	0225	10-27-2006	Q	I	989,000	00	Year	Code	Assessed	Year	Code	Assessed V	Year	Code	Assessed			
										2023	102U	0	2022	1020	0	2021	1020	0			
										Total		0		Total		0		Total		0	
EXEMPTIONS				OTHER ASSESSMENTS				This signature acknowledges a visit by a Data Collector or Assessor													
Year	Code	Description		Amount	Code	Description	Number	Amount	Comm Int												
				Total	0.00																
ASSESSING NEIGHBORHOOD												APPRAISED VALUE SUMMARY									
Nbhd		Nbhd Name		B		Tracing		Batch		Appraised Bldg. Value (Card)						0					
0001								HYAN		Appraised Xf (B) Value (Bldg)						0					
												Appraised Ob (B) Value (Bldg)						0			
												Appraised Land Value (Bldg)						0			
												Special Land Value						0			
												Total Appraised Parcel Value						0			
												Valuation Method						C			
												Total Appraised Parcel Value						0			
BUILDING PERMIT RECORD										VISIT / CHANGE HISTORY											
Permit Id	Issue Date	Type	Description	Amount	Insp Date	% Comp	Date Comp	Comments		Date	Id	Type	Is	Cd	Purpost/Result						
201501841	09-09-2015	CND	Condominium	118,867	05-06-2016	0		TENANT FIT OUT FOR UNIT		05-07-2020	WD			FR	Field Review						
										10-29-2018	SR	02		03	Cycl Insp Comp						
										05-01-2018	TR	03		16	In Office Review						
										01-21-2016	AL	22		22	Change of Address						
										03-09-2015	TP	03		16	In Office Review						
LAND LINE VALUATION SECTION																					
B	Use Code	Description	Zone	Dist	Land Type	Land Units	Unit Price	Size Adj	Site Index	Cond.	Nbhd.	Nbhd. Adj	Notes		Location Adjustmen	Adj Unit P	Land Value				
1	102U	Condominium M	DV	4		0 SF	165,000.00	1.00000	5	1.00	0001	1.000				0.0000	165,000	0			
Total Card Land Units						0	SF	Parcel Total Land Area						0.00	Total Land Value				0		

CONSTRUCTION DETAIL			CONSTRUCTION DETAIL (CONTINUED)		
Element	Cd	Description	Element	Cd	Description
Style	55	Condominium			
Model	05	Res Condo			
Bedrm Func	C	Average			
Stories	2.5	2 1/2 Stories			
Occupancy					
Interior Wall 1	05	Drywall			
Interior Wall 2					
Interior Floor 1	14	Carpet			
Interior Floor 2					
Heat Fuel	03	Gas			
Heat Type	04	Hot Air			
AC Type	03	Central			
Bedrooms	03	3 Bedrooms			
Full Baths	2	2 Full			
Half Baths	1				
Extra Fixtures	0				
Total Rooms	5				
Bath Style	03	Modern			
Kitchen Style	04	Typical for Gr			
Master Deed L	2232				
Bath Split	21	2 Full-1 Half			
Foundation	03	Conc. Slab			
AC Type Alt					
Sewer Occupan					
CONDO DATA					
Parcel Id	105421	C 0017	Owne	4.1	
	FLAGSHIP ESTS	B 1	S 1		
Adjust Type	Code	Description	Factor%		
Condo Flr			100		
Condo Unit	MKT0	MKT0	100		
COST / MARKET VALUATION					
Building Value New		462,181			
Year Built		2015			
Effective Year Built		2017			
Depreciation Code		A			
Remodel Rating					
Year Remodeled					
Depreciation %		2			
Functional Obsol		0			
External Obsol		0			
Trend Factor		1			
Condition		UC			
Condition %		0			
Percent Good		0			
Cns Sect Rcnld		0			
Dep % Ovr					
Dep Ovr Comment					
Misc Imp Ovr					
Misc Imp Ovr Comment					
Cost to Cure Ovr					
Cost to Cure Ovr Comment					

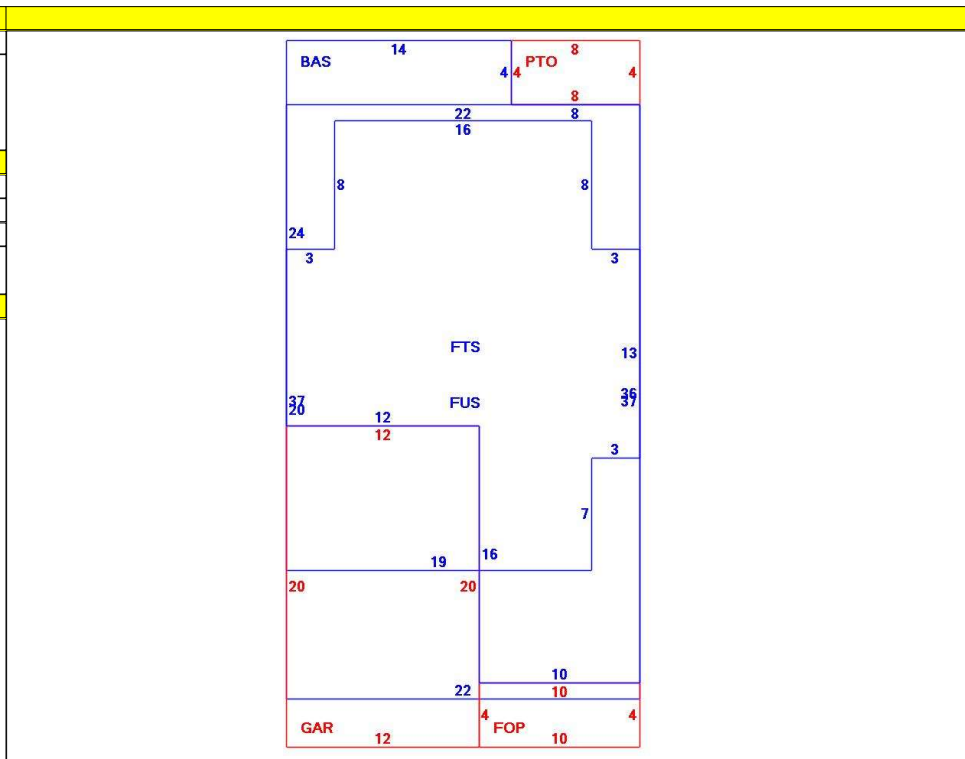

OB - OUTBUILDING & YARD ITEMS(L) / XF - BUILDING EXTRA FEATURES(B)

Code	Description	L/B	Units	Unit Price	Yr Blt	Cond. Cd	% Gd	Grade	Grade Adj.	Appr. Value
PAT1	Patio- Average	L	32	5.89	2015		0		0.00	0
FOP	Open Porch-ro	B	40	55.00	2019		0		0.00	0
GAR	Attached Gara	B	240	40.00	2019		0		0.00	0

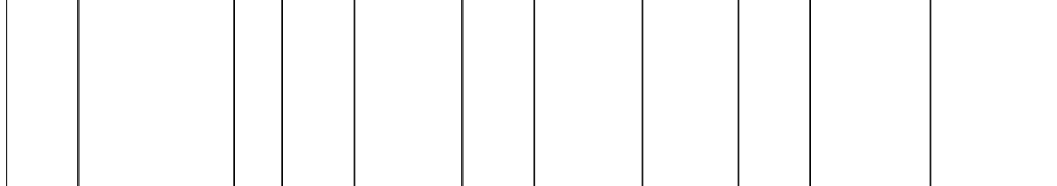

BUILDING SUB-AREA SUMMARY SECTION

Code	Description	Living Area	Floor Area	Eff Area	Unit Cost	Undeprec Value
BAS	First Floor	656	656	656	229.14	150,318
FOP	Open Porch	0	40	0	0.00	0
FTS	Finished Third Story	547	547	547	229.14	125,341
FUS	Upper Story	814	814	814	229.14	186,522
GAR	Attached Garage	0	240	0	0.00	0
PTO	Patio	0	32	0	0.00	0
Ttl Gross Liv / Lease Area		2,017	2,329	2,017		462,181

