

CURRENT OWNER		TOPO	UTILITIES	STRT / ROAD	LOCATION	CURRENT ASSESSMENT				801 FY2024 BARNSTABLE, MA
EAGAN, WILLIAM P JR TR LAGO REALTY TRUST 70 NEWPORT LN OSTERVILLE MA 02655		1 Level	6 Septic	1 Paved		Description	Code	Assessed	Assessed	
			4 Gas			RESIDNTL	1010	394,100	394,100	
			2 Public Water			RES LAND	1010	334,900	334,900	
SUPPLEMENTAL DATA										VISION
Alt Prcl ID			Plan Ref.							
Split Zonin			Land Ct# 31373-D							
BID Parcel			#SR							
ResExpt Q			Life Estate							
#DL 1 LOT 88			PP STATU							
#DL 2			Assoc Pid#							
GIS ID F_965281_2695456						Total 729,000 729,000				

RECORD OF OWNERSHIP		BK-VOL/PAGE	SALE DATE	Q/U	V/I	SALE PRIC	VC	PREVIOUS ASSESSMENTS (HISTORY)						
EAGAN, WILLIAM P JR TR		C182686	0	03-29-2007	U	I	100	1A	Year	Code	Assessed	Year	Code	Assessed
EAGAN, WILLIAM P JR		C174170	0	08-25-2004	U	I	100	1A	2023	1010	355,600	2022	1010	301,400
EAGAN, WILLIAM P JR TR		C171512	0	12-09-2003	U	I	1	1F		1010	311,400		1010	215,300
EAGAN, WILLIAM P		C171075	0	10-31-2003	U	I	1	1A					1010	5,200
EAGAN, WILLIAM P JR TR		C164298	0	02-13-2002	U	I	100	1F	Total		667,000	Total		516,700
		Total								Total				495,400

EXEMPTIONS				OTHER ASSESSMENTS				This signature acknowledges a visit by a Data Collector or Assessor					
Year	Code	Description	Amount	Code	Description	Number	Amount	Comm	Int				
2024	N5C	NO RESIDENTIAL EXEMPTION	0.00										
Total			0.00										

ASSESSING NEIGHBORHOOD				APPRAISED VALUE SUMMARY				
Nbhd	Nbhd Name	B	Tracing	Batch				
0110				OSTVIL				
NOTES				Appraised Bldg. Value (Card)				336,900
				Appraised Xf (B) Value (Bldg)				52,000
				Appraised Ob (B) Value (Bldg)				5,200
				Appraised Land Value (Bldg)				334,900
				Special Land Value				0
				Total Appraised Parcel Value				729,000
				Valuation Method				C
				Total Appraised Parcel Value				729,000

BUILDING PERMIT RECORD								VISIT / CHANGE HISTORY						
Permit Id	Issue Date	Type	Description	Amount	Insp Date	% Comp	Date Comp	Comments	Date	Id	Type	Is	Cd	Purpost/Result
19-3927	11-22-2019	835	Sid/Wind/Roof/	12,907		100		replace 6 windows	05-28-2020	LS			FR	Field Review
									12-06-2016	KM	02		03	Cycl Insp Comp
									04-07-2014	JR	03		16	In Office Review
									05-06-2008	PT	02		14	Cyclical Inspection
									10-20-1999	PT	01		00	Meas/Listed-Interior Acces

LAND LINE VALUATION SECTION																	
B	Use Code	Description	Zone	LA	Land Units	Unit Price	Size Adj	AC Disc	Site Index	Cond.	Nbhd.	Nbhd. Adj	Notes	Location Adjustmen	Adj Unit P	Land Value	
1	1010	Single Fam M-0	RC	3	0.350	AC	176,344.00	2.46674	1.0000	5	1.00	0109	2.200		1.0000	956,983.6	334,900
Total Card Land Units					0.35	AC	Parcel Total Land Area					0.35	Total Land Value			334,900	

CONSTRUCTION DETAIL			CONSTRUCTION DETAIL (CONTINUED)		
Element	Cd	Description	Element	Cd	Description
Style	04	Cape Cod			
Model	01	Residential			
Grade:	C	Average			
Stories	1.75	1 3/4 Stories			
Exterior Wall 1	14	Wood Shingle			
Exterior Wall 2	11	Clapboard			
RooF Structure	03	Gable/Hip			
RooF Cover	03	Asph/F Gls/Cmp			
Interior Wall 1	05	Drywall			
Interior Wall 2					
Interior Floor 1	12	Hardwood			
Interior Floor 2	14	Carpet			
Heat Fuel	03	Gas			
Heat Type	05	Hot Water			
AC Type	01	None			
Bedrooms	03	3 Bedrooms			
Full Baths	2				
Half Baths	0				
Extra Fixtures					
Total Rooms	6	6 Rooms			
Bath Style					
Kitchen Style					
Occupancy					
Usrflid 105					
Accessory Apt					
Foundation Alt	01	Poured Conc.			
Rms Prts					
Bath Split	20	2 Full-0 Half			
			CONDO DATA		
Parcel Id			C	Owne	0.0
Adjust Type		Code	Description	Factor%	
Condo Flr					
Condo Unit					
			COST / MARKET VALUATION		
Building Value New		405,953			
Year Built		1983			
Effective Year Built		1997			
Depreciation Code		A			
Remodel Rating					
Year Remodeled					
Depreciation %		17			
Functional Obsol		0			
External Obsol		0			
Trend Factor		1			
Condition					
Condition %					
Percent Good		83			
RCNLD		336,900			
Dep % Ovr					
Dep Ovr Comment					
Misc Imp Ovr					
Misc Imp Ovr Comment					
Cost to Cure Ovr					
Cost to Cure Ovr Comment					

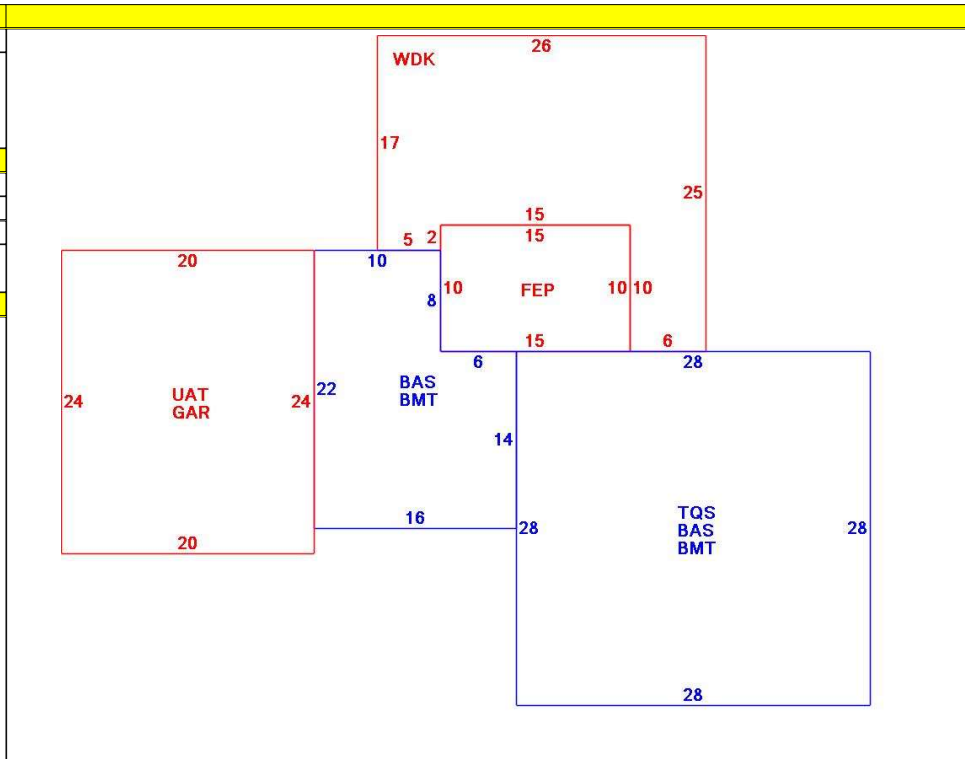

OB - OUTBUILDING & YARD ITEMS(L) / XF - BUILDING EXTRA FEATURES(B)										
Code	Description	L/B	Units	Unit Price	Yr Blt	Cond. Cd	% Gd	Grade	Grade Adj.	Appr. Value
FPL2	Fireplace 1.5 s	B	1	6000.00	1999		83		0.00	5,000
WDC	Wood Decking	L	460	20.00	1999		60		0.00	5,200
FEP	Enclosed porc	B	150	70.00	1999		83		0.00	8,700
GAR	Attached Gara	B	480	40.00	1999		83		0.00	15,000
BMT	Basement-Unfi	B	1,088	26.01	1999		83		0.00	23,300

BUILDING SUB-AREA SUMMARY SECTION						
Code	Description	Living Area	Floor Area	Eff Area	Unit Cost	Undeprec Value
BAS	First Floor	1,088	1,088	1,088	246.63	268,333
BMT	Basement Area	0	1,088	0	0.00	0
FEP	Enclosed Porch	0	150	0	0.00	0
GAR	Attached Garage	0	480	0	0.00	0
TQS	Three Quarter Story	510	784	510	160.44	125,781
UAT	Attic, Unfinished	0	480	48	24.66	11,838
WDK	Wood Deck	0	460	0	0.00	0
Ttl Gross Liv / Lease Area		1,598	4,530	1,646		405,952

