

CURRENT OWNER				TOPO	UTILITIES	STRT / ROAD	LOCATION	CURRENT ASSESSMENT					
FOWLER, CHARLES W 87 LIAM LANE CENTERVILLE MA 02632				3	Below Street	6	Septic	1	Paved	Description	Code	Assessed	Assessed
						4	Gas			RESIDENTL	1010	1,117,200	1,117,200
						2	Public Water			RES LAND	1010	192,800	192,800
SUPPLEMENTAL DATA													
Alt Prcl ID						Plan Ref.							
Split Zonin						Land Ct# 37478-C							
BID Parcel						#SR							
ResExpt Q YES:						Life Estate							
#DL 1 LOT 21						PP STATU							
#DL 2						Assoc Pid#							
GIS ID F_966132_2697767									Total 1,310,000 1,310,000				

801
 FY2024
 BARNSTABLE, MA

VISION

RECORD OF OWNERSHIP				BK-VOL/PAGE	SALE DATE	Q/U	V/I	SALE PRIC	VC	PREVIOUS ASSESSMENTS (HISTORY)									
FOWLER, CHARLES W				C208365	0	12-23-2015	U	I	727,500	1V	Year	Code	Assessed	Year	Code	Assessed	Year	Code	Assessed
GAUGHAN, SUSAN E				17118	0160	06-19-2003	U	I	10	1F	2023	1010	1,000,700	2022	1010	838,900	2021	1010	687,900
GAUGHAN, SUSAN E				C155271	0	10-22-1999	Q	I	190,000	00		1010	190,500		1010	135,500		1010	135,500
MURPHY, GRETCHEN H				C149404	0	07-17-1998	Q	I	142,590	00					1010			1010	33,300
CURLEY, PATRICK M & LORRAINE				C92295	0	06-15-1983	Q	I	70,950	U									
Total											1,191,200	Total	974,400	Total	856,700				

EXEMPTIONS				OTHER ASSESSMENTS				This signature acknowledges a visit by a Data Collector or Assessor												
Year	Code	Description	Amount	Code	Description	Number	Amount	Comm Int												
2019	5C	RESIDENTIAL EXEMPTION	0.00																	
Total			0.00																	

ASSESSING NEIGHBORHOOD				APPRAISED VALUE SUMMARY			
Nbhd	Nbhd Name	B	Tracing	Batch			
0106			CENVIL				

NOTES												APPRAISED VALUE SUMMARY			
												Appraised Bldg. Value (Card)	1,004,700		
												Appraised Xf (B) Value (Bldg)	79,600		
												Appraised Ob (B) Value (Bldg)	32,900		
												Appraised Land Value (Bldg)	192,800		
												Special Land Value	0		
												Total Appraised Parcel Value	1,310,000		
												Valuation Method	C		
												Total Appraised Parcel Value	1,310,000		

BUILDING PERMIT RECORD								VISIT / CHANGE HISTORY							
Permit Id	Issue Date	Type	Description	Amount	Insp Date	% Comp	Date Comp	Comments	Date	Id	Type	Is	Cd	Purpost/Result	
18-3276	10-03-2018	835	Sid/Wind/Roof/	65,000		100		RE-ROOF AND RESIDE AND	05-28-2020	LS			FR	Field Review	
17-3702	11-03-2017	804	Addn Alt-Res	65,000	04-10-2018	100	06-30-2018	2 Dormers, Roof and Sidewall	09-11-2018	SR	02		02	Bldg Permit Completed	
77344	05-11-2004	WD	Wood Deck	10,000	06-13-2005	100	01-01-2005	10 X 14 SUNRM	07-24-2018	GC	03		16	In Office Review	
72518	10-24-2003	DE	Demolish	10,000	01-15-2003	100	12-31-2003	DEMO ACCESSORY BLDG	09-14-2016	JR	03		20	Sale Review	
72515	10-24-2003	AD	Addition	193,000	06-01-2006	100	01-01-2005	ADD GAR/BDRM OVER/KIT/F	02-26-2015	JR	03		03	Cycl Insp Comp	
48921	09-26-2000	AD	Addition	3,600	01-05-2001	100	06-30-2001	16 X 16 SUNRM	05-20-2008	PT	02		14	Cyclical Inspection	
42868	12-06-1999	AD	Addition	5,000	01-05-2001	100	01-01-2001	FIREPLACE	06-07-2006	MF	02		02	Bldg Permit Completed	

LAND LINE VALUATION SECTION																	
B	Use Code	Description	Zone	LA	Land Units	Unit Price	Size Adj	AC Disc	Site Index	Cond.	Nbhd.	Nbhd. Adj	Notes	Location Adjustmen	Adj Unit P	Land Value	
1	1010	Single Fam M-0	RD-	3	0.650	AC	176,344.00	1.46256	1.0000	5	1.00	0106	1.150		1.0000	296,592.9	192,800

CONSTRUCTION DETAIL			CONSTRUCTION DETAIL (CONTINUED)		
Element	Cd	Description	Element	Cd	Description
Style	04	Cape Cod			
Model	01	Residential			
Grade:	A	Luxury			
Stories	1.75	1 3/4 Stories			
Exterior Wall 1	14	Wood Shingle			
Exterior Wall 2	11	Clapboard			
RooF Structure	03	Gable/Hip			
RooF Cover	03	Asph/F Gls/Cmp			
Interior Wall 1	05	Drywall			
Interior Wall 2					
Interior Floor 1	14	Carpet			
Interior Floor 2	12	Hardwood			
Heat Fuel	03	Gas			
Heat Type	04	Hot Air			
AC Type	03	Central			
Bedrooms	03	3 Bedrooms			
Full Baths	3				
Half Baths	0				
Extra Fixtures					
Total Rooms	11				
Bath Style					
Kitchen Style	02	Modernized			
Occupancy					
Usrflid 105					
Accessory Apt					
Foundation Alt	01	Poured Conc.			
Rms Prts					
Bath Split	30	3 Full-0 Half			

CONDO DATA				
Parcel Id		C		Ownr 0.0
			B	S
Adjust Type	Code	Description	Factor%	
Condo Flr				
Condo Unit				

COST / MARKET VALUATION		
Building Value New		1,210,464
Year Built		1983
Effective Year Built		1997
Depreciation Code		A
Remodel Rating		
Year Remodeled		
Depreciation %	17	
Functional Obsol	0	
External Obsol	0	
Trend Factor	1	
Condition		
Condition %		
Percent Good	83	
RCNLD		1,004,700
Dep % Ovr		
Dep Ovr Comment		
Misc Imp Ovr		
Misc Imp Ovr Comment		
Cost to Cure Ovr		
Cost to Cure Ovr Comment		

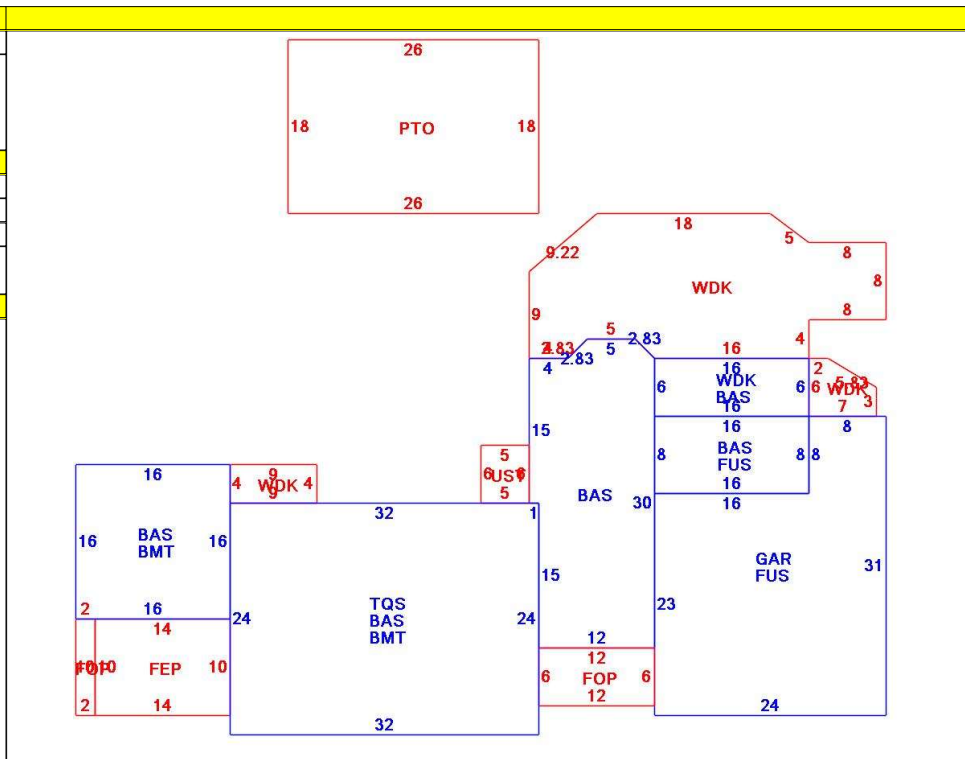

OB - OUTBUILDING & YARD ITEMS(L) / XF - BUILDING EXTRA FEATURES(B)										
Code	Description	L/B	Units	Unit Price	Yr Blt	Cond. Cd	% Gd	Grade	Grade Adj.	Appr. Value
SPL3	Pool Gunite	L	450	75.00	1985		32	00	1.00	12,500
FPL2	Fireplace 1.5 s	B	1	6000.00	1999		83		0.00	5,000
BFA1	Bsmt Fin-Goo	B	484	32.56	1999		83		0.00	13,100
WDC	Wood Decking	L	624	17.68	2007		76		0.00	7,700
FOP	Open Porch-ro	B	92	47.85	2007		100	A	0.00	4,600
FOP	Open Porch-ro	B	140	47.85	2007		100	A	0.00	6,100
GAR	Attached Gara	B	616	32.74	2007		100	A	0.00	17,500
UST	Utility Storage-	B	30	13.30	2007		83		0.00	400
BMT	Basement-Unfi	B	1,024	27.42	1996		100		0.00	28,500
FPLG	Gas Fireplace-	B	2	2215.00	2008		100		0.00	4,400

BUILDING SUB-AREA SUMMARY SECTION						
Code	Description	Living Area	Floor Area	Eff Area	Unit Cost	Undeprec Value
BAS	First Floor	1,637	1,637	1,637	420.30	688,031
BMT	Basement Area	0	1,024	0	0.00	0
FEP	Enclosed Porch	0	140	0	0.00	0
FOP	Open Porch	0	92	0	0.00	0
FUS	Upper Story	744	744	744	420.30	312,703
GAR	Attached Garage	0	616	0	0.00	0
PTO	Patio	0	468	0	0.00	0
TQS	Three Quarter Story	499	768	499	273.09	209,730
UST	Utility Enclosure	0	30	0	0.00	0
WDK	Wood Deck	0	625	0	0.00	0
Ttl Gross Liv / Lease Area		2,880	6,144	2,880		1,210,464



CURRENT OWNER			TOPO		UTILITIES		STRT / ROAD		LOCATION		CURRENT ASSESSMENT					
FOWLER, CHARLES W 87 LIAM LANE CENTERVILLE MA 02632			3	Below Street	6	Septic	1	Paved			Description	Code	Assessed	Assessed		
					4	Gas					RESIDNTL	1010	1,117,200	1,117,200		
					2	Public Water					RES LAND	1010	192,800	192,800		
SUPPLEMENTAL DATA																
Alt Prcl ID				Split Zonin				Plan Ref.								
BID Parcel				ResExpt Q YES:				Land Ct# 37478-C								
#DL 1 LOT 21				#DL 2				Life Estate								
GIS ID F_966132_2697767				Assoc Pid#												
											Total		1,310,000		1,310,000	

801
 FY2024
 BARNSTABLE, MA

VISION

RECORD OF OWNERSHIP			BK-VOL/PAGE		SALE DATE		Q/U		V/I		SALE PRIC		VC		PREVIOUS ASSESSMENTS (HISTORY)								
															Year	Code	Assessed	Year	Code	Assessed	Year	Code	Assessed
															2023	1010	1,000,700	2022	1010	838,900	2021	1010	687,900
																1010	190,500		1010	135,500		1010	135,500
																						1010	33,300
											Total		1,191,200		Total		974,400		Total		856,700		

EXEMPTIONS				OTHER ASSESSMENTS				This signature acknowledges a visit by a Data Collector or Assessor													
Year	Code	Description	Amount	Code	Description	Number	Amount	Comm Int													
			Total																		

ASSESSING NEIGHBORHOOD				APPRAISED VALUE SUMMARY					
Nbhd	Nbhd Name	B	Tracing	Batch				Appraised Bldg. Value (Card)	1,004,700
0106			CENVIL				Appraised Xf (B) Value (Bldg)	79,600	
							Appraised Ob (B) Value (Bldg)	32,900	
							Appraised Land Value (Bldg)	192,800	
							Special Land Value	0	
							Total Appraised Parcel Value	1,310,000	
							Valuation Method	C	
							Total Appraised Parcel Value	1,310,000	

NOTES												VISIT / CHANGE HISTORY					
												Date	Id	Type	Is	Cd	Purpost/Result

BUILDING PERMIT RECORD												VISIT / CHANGE HISTORY					
Permit Id	Issue Date	Type	Description	Amount	Insp Date	% Comp	Date Comp	Comments	Date	Id	Type	Is	Cd	Purpost/Result			

LAND LINE VALUATION SECTION																	
B	Use Code	Description	Zone	LA	Land Units	Unit Price	Size Adj	AC Disc	Site Index	Cond.	Nbhd.	Nbhd. Adj	Notes	Location Adjustmen	Adj Unit P	Land Value	
Total Card Land Units					Parcel Total Land Area					Total Land Value							

