

CURRENT OWNER		TOPO	UTILITIES	STRT / ROAD	LOCATION	CURRENT ASSESSMENT			
MURPHY, MARY K TR EDWARD F MURPHY 1995 REV TR 8104 GATES BLUFF COURT CHESTERFIELD VA 23832		1 Level	2 Public Water			Description RESIDNTL RES LAND	Code 1010 1010	Assessed 495,100 288,100	Assessed 495,100 288,100
			4 Gas	1 Paved					
			6 Septic						
SUPPLEMENTAL DATA									
Alt Prcl ID		Split Zonin		Plan Ref. 185/105					
BID Parcel		ResExpt Q		Land Ct#					
#DL 1		#DL 2		Life Estate					
GIS ID F_944878_2691785				PP STATU					
				Assoc Pid#					
						Total	783,200	783,200	

801
 FY2024
 BARNSTABLE, MA
VISION

RECORD OF OWNERSHIP		BK-VOL/PAGE	SALE DATE	Q/U	V/I	SALE PRIC	VC	PREVIOUS ASSESSMENTS (HISTORY)					
MURPHY, MARY K TR	31146	0008	05-01-2017	U	I	0	1F	Year	Code	Assessed	Year	Code	Assessed
MURPHY, EDWARD F TR	11297	0020	03-20-1998	U	I	1	1A	2023	1010	420,900	2022	1010	348,300
MURPHY, EDWARD F	10016	0197	01-15-1996	U	I	1	A		1010	285,000	2021	1010	182,600
MURPHY, EDWARD F & MARY	1449	0019	09-12-1969	U		0						1010	3,100
								Total	705,900	Total	530,900	Total	483,300

EXEMPTIONS			OTHER ASSESSMENTS					
Year	Code	Description	Amount	Code	Description	Number	Amount	Comm Int
Total			0.00					

This signature acknowledges a visit by a Data Collector or Assessor

ASSESSING NEIGHBORHOOD				APPRAISED VALUE SUMMARY			
Nbhd	Nbhd Name	B	Tracing	Batch			
0109			COTUIT				
NOTES				Appraised Bldg. Value (Card) 458,800 Appraised Xf (B) Value (Bldg) 33,200 Appraised Ob (B) Value (Bldg) 3,100 Appraised Land Value (Bldg) 288,100 Special Land Value 0 Total Appraised Parcel Value 783,200 Valuation Method C Total Appraised Parcel Value 783,200			

BUILDING PERMIT RECORD						VISIT / CHANGE HISTORY								
Permit Id	Issue Date	Type	Description	Amount	Insp Date	% Comp	Date Comp	Comments	Date	Id	Type	Is	Cd	Purpost/Result
									07-12-2022	BM	22		22	Change of Address
									05-27-2020	DM			FR	Field Review
									08-12-2013	RB	03		03	Cycl Insp Comp
									03-25-2005	PT	02		01	Meas/Est
									10-10-2003	PT	02		01	Meas/Est
									06-14-1999	FS	01		00	Meas/Listed-Interior Acces

LAND LINE VALUATION SECTION																	
B	Use Code	Description	Zone	LA	Land Units	Unit Price	Size Adj	AC Disc	Site Index	Cond.	Nbhd.	Nbhd. Adj	Notes	Location Adjustmen	Adj Unit P	Land Value	
1	1010	Single Fam M-0	RF	2	0.690 AC	176,344.00	1.39292	1.0000	5	1.00	0108	1.700		1.0000	417,582.5	288,100	
Total Card Land Units					0.69 AC	Parcel Total Land Area					0.69	Total Land Value					288,100

CONSTRUCTION DETAIL			CONSTRUCTION DETAIL (CONTINUED)		
Element	Cd	Description	Element	Cd	Description
Style	06	Conventional			
Model	01	Residential			
Grade:	C+	Average Plus			
Stories	2	2 Stories			
Exterior Wall 1	14	Wood Shingle			
Exterior Wall 2					
RooF Structure	03	Gable/Hip			
RooF Cover	03	Asph/F Gls/Cmp			
Interior Wall 1	03	Plastered			
Interior Wall 2	05	Drywall			
Interior Floor 1	09	Pine/Soft Wood			
Interior Floor 2					
Heat Fuel	03	Gas			
Heat Type	05	Hot Water			
AC Type	01	None			
Bedrooms	05	5 Bedrooms			
Full Baths	2				
Half Baths	0				
Extra Fixtures					
Total Rooms	9	9 Rooms			
Bath Style					
Kitchen Style					
Occupancy					
Usrflid 105					
Accessory Apt					
Foundation Alt	10	Brick Ftgs			
Rms Prts					
Bath Split	20	2 Full-0 Half			
			CONDO DATA		
			Parcel Id	C	Owne 0.0
			Adjust Type Code Description Factor%		
			Condo Flr		
			Condo Unit		
			COST / MARKET VALUATION		
			Building Value New		628,462
			Year Built		1880
			Effective Year Built		1984
			Depreciation Code		G
			Remodel Rating		
			Year Remodeled		
			Depreciation %		27
			Functional Obsol		0
			External Obsol		0
			Trend Factor		1
			Condition		
			Condition %		
			Percent Good		73
			RCNLD		458,800
			Dep % Ovr		
			Dep Ovr Comment		
			Misc Imp Ovr		
			Misc Imp Ovr Comment		
			Cost to Cure Ovr		
			Cost to Cure Ovr Comment		

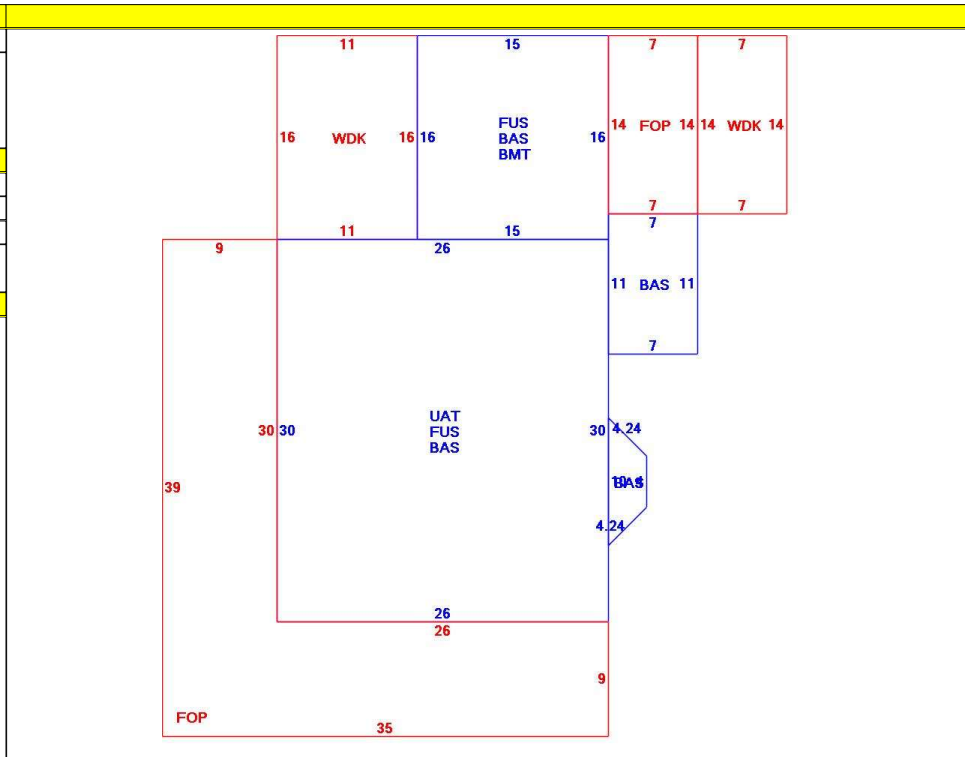

OB - OUTBUILDING & YARD ITEMS(L) / XF - BUILDING EXTRA FEATURES(B)										
Code	Description	L/B	Units	Unit Price	Yr Blt	Cond. Cd	% Gd	Grade	Grade Adj.	Appr. Value
FPL3	Fireplace 2 sto	B	1	7000.00	1984		73		0.00	5,100
FPO	Ext FP Openin	B	1	2000.00	1984		73		0.00	1,500
WDC	Wood Decking	L	274	20.00	1996		54		0.00	3,100
FOP	Open Porch-ro	B	683	55.00	1984		73		0.00	18,800
BMT	Basement-Unfi	B	240	26.01	1984		73		0.00	7,800

BUILDING SUB-AREA SUMMARY SECTION						
Code	Description	Living Area	Floor Area	Eff Area	Unit Cost	Undeprec Value
BAS	First Floor	1,118	1,118	1,118	283.60	317,067
BMT	Basement Area	0	240	0	0.00	0
FOP	Open Porch	0	683	0	0.00	0
FUS	Upper Story	1,020	1,020	1,020	283.60	289,274
UAT	Attic, Unfinished	0	780	78	28.36	22,121
WDK	Wood Deck	0	274	0	0.00	0
Ttl Gross Liv / Lease Area		2,138	4,115	2,216		628,462

