

CURRENT OWNER			TOPO	UTILITIES	STRT / ROAD	LOCATION	CURRENT ASSESSMENT				
PAPPAS, PETER F							Description	Code	Assessed	Assessed	801 FY2024 BARNSTABLE, MA
126 RALYN ROAD							RESIDENTL	1010	405,000	405,000	
COTUIT MA 02635							RES LAND	1010	219,600	219,600	VISION
SUPPLEMENTAL DATA							Total				
Alt Prcl ID			Split Zonin		Plan Ref. 229/53						
#DL 1 LOT 11			#DL 2		Land Ct#						
GIS ID F_944628_2690767			Assoc Pid#								

RECORD OF OWNERSHIP			BK-VOL/PAGE	SALE DATE	Q/U	V/I	SALE PRIC	VC	PREVIOUS ASSESSMENTS (HISTORY)					
PAPPAS, PETER F	31347	0212	06-19-2018	U	I	100	1F	Year	Code	Assessed	Year	Code	Assessed	
PAPPAS, PETER F TR	31347	0209	05-23-2016	U	I	0	1F	2023	1010	359,800	2022	1010	303,000	
PAPPAS, ATHENA L TR	9258	0270	06-15-1994	U	I	1	A		1010	199,600		1010	137,300	
PAPPAS, FRED F & ATHENA L	6114	0007	01-15-1988	U	I	1	A					1010	6,500	
PAPPAS, PETER F	4607	0281	07-15-1985	Q	I	128,000	U	Total		559,400	Total		440,300	
								Total		401,700				

EXEMPTIONS			OTHER ASSESSMENTS					
Year	Code	Description	Amount	Code	Description	Number	Amount	Comm Int
Total			0.00					

ASSESSING NEIGHBORHOOD			NOTES			
Nbhd	Nbhd Name	B	Tracing	Batch		
0107				COTUIT		

BUILDING PERMIT RECORD								VISIT / CHANGE HISTORY						
Permit Id	Issue Date	Type	Description	Amount	Insp Date	% Comp	Date Comp	Comments	Date	Id	Type	Is	Cd	Purpost/Result
18-3959	12-03-2018	822	Insulation	6,823		100		Insulation; See Contract	05-27-2020	DM			FR	Field Review
201105278	10-12-2011	WD	Wood Deck	4,500	08-07-2012	100	06-30-2013	16X16 & 16X20 WDK	08-13-2013	RB	03		03	Cycl Insp Comp
200903851	08-19-2009	NR	New Roof	8,000	06-30-2010	100	06-30-2010	STRP OLD	02-28-2005	PT	02		01	Meas/Est
B27611	03-02-1985	DW	Dwelling	60,000	12-15-1985	100	06-30-1986	CO 1.5 ST						

LAND LINE VALUATION SECTION																
B	Use Code	Description	Zone	LA	Land Units	Unit Price	Size Adj	AC Disc	Site Index	Cond.	Nbhd.	Nbhd. Adj	Notes	Location Adjustmen	Adj Unit P	Land Value
1	1010	Single Fam M-0	RF	2	0.490	AC	176,344.00	1.81499	1.0000	5	1.00	0107	1.400		1.0000	448,090.1
Total Card Land Units					0.49	AC	Parcel Total Land Area					0.49	Total Land Value			219,600

CONSTRUCTION DETAIL			CONSTRUCTION DETAIL (CONTINUED)		
Element	Cd	Description	Element	Cd	Description
Style	04	Cape Cod			
Model	01	Residential			
Grade:	C	Average			
Stories	1.5	1 1/2 Stories			
Exterior Wall 1	14	Wood Shingle			
Exterior Wall 2	11	Clapboard			
Roof Structure	03	Gable/Hip			
Roof Cover	03	Asph/F Gls/Cmp			
Interior Wall 1	05	Drywall			
Interior Wall 2					
Interior Floor 1	14	Carpet			
Interior Floor 2	12	Hardwood			
Heat Fuel	02	Oil			
Heat Type	05	Hot Water			
AC Type	01	None			
Bedrooms	04	4 Bedrooms			
Full Baths	2				
Half Baths	0				
Extra Fixtures					
Total Rooms	8	8 Rooms			
Bath Style					
Kitchen Style					
Occupancy					
Usrflid 105					
Accessory Apt					
Foundation Alt	01	Poured Conc.			
Rms Prts					
Bath Split	20	2 Full-0 Half			

CONDO DATA			
Parcel Id		C	Ownr 0.0
Adjust Type	Code	Description	Factor%
Condo Flr			
Condo Unit			

COST / MARKET VALUATION	
Building Value New	425,117
Year Built	1985
Effective Year Built	1998
Depreciation Code	A
Remodel Rating	
Year Remodeled	
Depreciation %	16
Functional Obsol	0
External Obsol	0
Trend Factor	1
Condition	
Condition %	
Percent Good	84
RCNLD	357,100
Dep % Ovr	
Dep Ovr Comment	
Misc Imp Ovr	
Misc Imp Ovr Comment	
Cost to Cure Ovr	
Cost to Cure Ovr Comment	

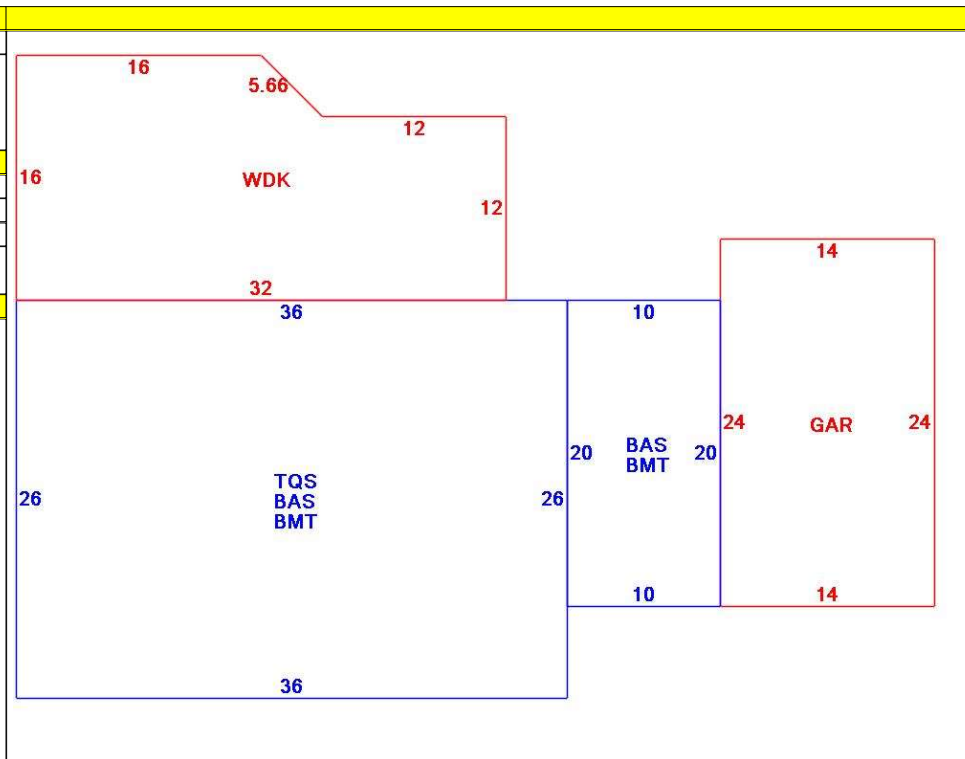

OB - OUTBUILDING & YARD ITEMS(L) / XF - BUILDING EXTRA FEATURES(B)										
Code	Description	L/B	Units	Unit Price	Yr Blt	Cond. Cd	% Gd	Grade	Grade Adj.	Appr. Value
FPL2	Fireplace 1.5 s	B	1	6000.00	2000		84		0.00	5,000
GAR	Attached Gara	B	336	40.00	2000		84		0.00	12,100
BMT	Basement-Unfi	B	1,136	26.01	2000		84		0.00	24,300
WDC	Wood Deck w/	L	456	18.00	2011		84		0.00	6,500

BUILDING SUB-AREA SUMMARY SECTION						
Code	Description	Living Area	Floor Area	Eff Area	Unit Cost	Undeprec Value
BAS	First Floor	1,136	1,136	1,136	243.76	276,911
BMT	Basement Area	0	1,136	0	0.00	0
GAR	Attached Garage	0	336	0	0.00	0
TQS	Three Quarter Story	608	936	608	158.34	148,206
WDC	Wood Deck	0	456	0	0.00	0
Ttl Gross Liv / Lease Area		1,744	4,000	1,744		425,117

