

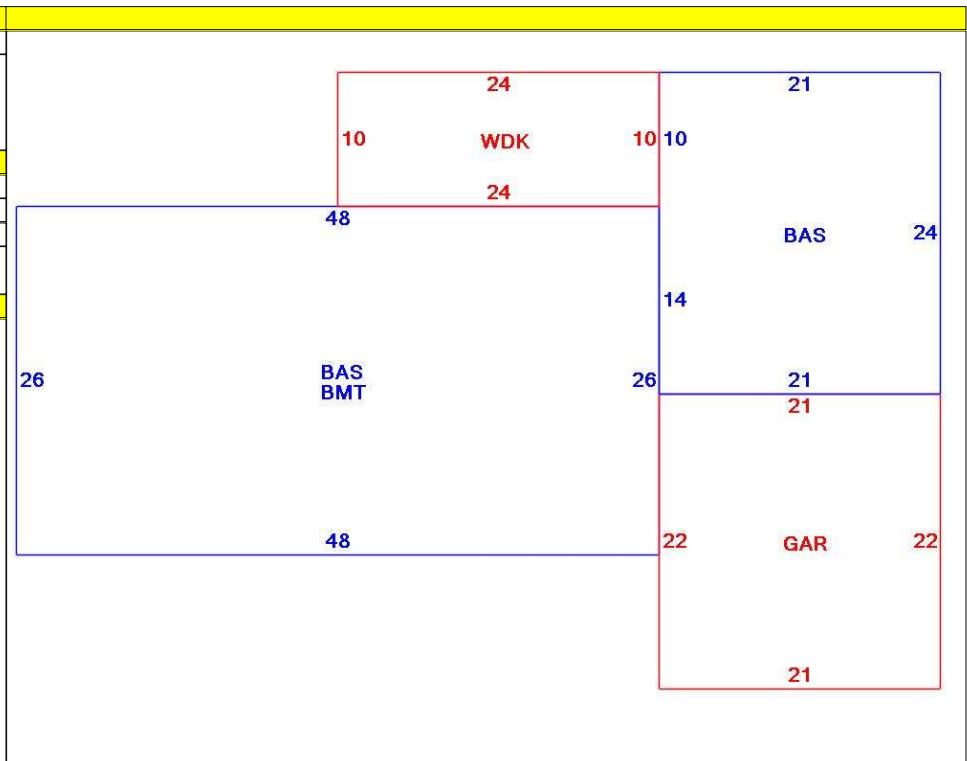

CONSTRUCTION DETAIL			CONSTRUCTION DETAIL (CONTINUED)		
Element	Cd	Description	Element	Cd	Description
Style	01	Ranch			
Model	01	Residential			
Grade:	C	Average			
Stories	1	1 Story			
Exterior Wall 1	14	Wood Shingle			
Exterior Wall 2	25	Vinyl Siding			
Roof Structure	03	Gable/Hip			
Roof Cover	03	Asph/F Gls/Cmp			
Interior Wall 1	05	Drywall			
Interior Wall 2					
Interior Floor 1	14	Carpet			
Interior Floor 2	12	Hardwood			
Heat Fuel	03	Gas			
Heat Type	05	Hot Water			
AC Type	03	Central			
Bedrooms	03	3 Bedrooms			
Full Baths	3				
Half Baths	0				
Extra Fixtures					
Total Rooms	7	7 Rooms			
Bath Style					
Kitchen Style					
Occupancy					
Usrflid 105					
Accessory Apt					
Foundation Alt	01	Poured Conc.			
Rms Prts					
Bath Split	30	3 Full-0 Half			
<b>CONDO DATA</b>			<b>COST / MARKET VALUATION</b>		
Parcel Id		C	Ownr	0.0	
Adjust Type	Code	Description	Factor%		
Condo Flr					
Condo Unit					
Building Value New		489,281			
Year Built		1973			
Effective Year Built		1992			
Depreciation Code		A			
Remodel Rating					
Year Remodeled					
Depreciation %		21			
Functional Obsol		0			
External Obsol		0			
Trend Factor		1			
Condition					
Condition %					
Percent Good		79			
RCNLD		386,500			
Dep % Ovr					
Dep Ovr Comment					
Misc Imp Ovr					
Misc Imp Ovr Comment					
Cost to Cure Ovr					
Cost to Cure Ovr Comment					



OB - OUTBUILDING & YARD ITEMS(L) / XF - BUILDING EXTRA FEATURES(B)										
Code	Description	L/B	Units	Unit Price	Yr Blt	Cond. Cd	% Gd	Grade	Grade Adj.	Appr. Value
FPL1	Fireplace 1 sto	B	1	5000.00	1994		79		0.00	4,000
WDC	Wood Deck w/	L	240	18.00	1996		54		0.00	2,600
GAR	Attached Gara	B	462	40.00	1994		79		0.00	13,900
BMT	Basement-Unfi	B	1,248	26.01	1994		79		0.00	24,400
SHED	Shed	L	100	18.00	2017		96		0.00	1,700
SOL1	Solar PV Pane	B	16	860.00	1994		0		0.00	0

BUILDING SUB-AREA SUMMARY SECTION						
Code	Description	Living Area	Floor Area	Eff Area	Unit Cost	Undeprec Value
BAS	First Floor	1,752	1,752	1,752	279.27	489,281
BMT	Basement Area	0	1,248	0	0.00	0
GAR	Attached Garage	0	462	0	0.00	0
WDK	Wood Deck	0	240	0	0.00	0
Ttl Gross Liv / Lease Area		1,752	3,702	1,752		489,281

