

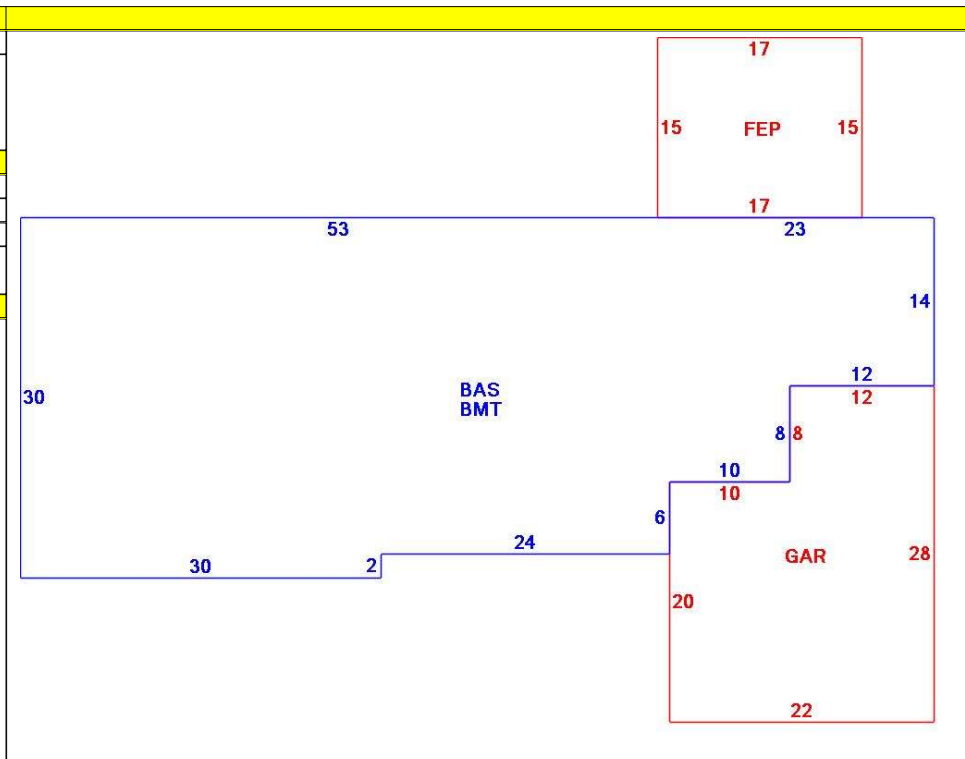

| CONSTRUCTION DETAIL |    |                | CONSTRUCTION DETAIL (CONTINUED) |    |             |
|---------------------|----|----------------|---------------------------------|----|-------------|
| Element             | Cd | Description    | Element                         | Cd | Description |
| Style               | 01 | Ranch          |                                 |    |             |
| Model               | 01 | Residential    |                                 |    |             |
| Grade:              | C+ | Average Plus   |                                 |    |             |
| Stories             | 1  | 1 Story        |                                 |    |             |
| Exterior Wall 1     | 14 | Wood Shingle   |                                 |    |             |
| Exterior Wall 2     |    |                |                                 |    |             |
| RooF Structure      | 03 | Gable/Hip      |                                 |    |             |
| RooF Cover          | 03 | Asph/F Gls/Cmp |                                 |    |             |
| Interior Wall 1     | 05 | Drywall        |                                 |    |             |
| Interior Wall 2     |    |                |                                 |    |             |
| Interior Floor 1    | 14 | Carpet         |                                 |    |             |
| Interior Floor 2    |    |                |                                 |    |             |
| Heat Fuel           | 03 | Gas            |                                 |    |             |
| Heat Type           | 05 | Hot Water      |                                 |    |             |
| AC Type             | 03 | Central        |                                 |    |             |
| Bedrooms            | 03 | 3 Bedrooms     |                                 |    |             |
| Full Baths          | 2  |                |                                 |    |             |
| Half Baths          | 1  |                |                                 |    |             |
| Extra Fixtures      |    |                |                                 |    |             |
| Total Rooms         | 7  | 7 Rooms        |                                 |    |             |
| Bath Style          |    |                |                                 |    |             |
| Kitchen Style       |    |                |                                 |    |             |
| Occupancy           |    |                |                                 |    |             |
| Usrflid 105         |    |                |                                 |    |             |
| Accessory Apt       |    |                |                                 |    |             |
| Foundation Alt      | 01 | Poured Conc.   |                                 |    |             |
| Rms Prts            |    |                |                                 |    |             |
| Bath Split          | 21 | 2 Full-1 Half  |                                 |    |             |

| CONDO DATA  |      |             |         |     |
|-------------|------|-------------|---------|-----|
| Parcel Id   |      | C           | Ownr    | 0.0 |
| Adjust Type | Code | Description | Factor% |     |
| Condo Flr   |      |             |         |     |
| Condo Unit  |      |             |         |     |

| COST / MARKET VALUATION  |         |
|--------------------------|---------|
| Building Value New       | 589,407 |
| Year Built               | 1981    |
| Effective Year Built     | 1996    |
| Depreciation Code        | A       |
| Remodel Rating           |         |
| Year Remodeled           |         |
| Depreciation %           | 18      |
| Functional Obsol         | 0       |
| External Obsol           | 0       |
| Trend Factor             | 1       |
| Condition                |         |
| Condition %              |         |
| Percent Good             | 82      |
| RCNLD                    | 483,300 |
| Dep % Ovr                |         |
| Dep Ovr Comment          |         |
| Misc Imp Ovr             |         |
| Misc Imp Ovr Comment     |         |
| Cost to Cure Ovr         |         |
| Cost to Cure Ovr Comment |         |



| OB - OUTBUILDING & YARD ITEMS(L) / XF - BUILDING EXTRA FEATURES(B) |                 |     |       |            |        |          |      |       |            |             |
|--|-----------------|-----|-------|------------|--------|----------|------|-------|------------|-------------|
| Code   | Description     | L/B | Units | Unit Price | Yr Blt | Cond. Cd | % Gd | Grade | Grade Adj. | Appr. Value |
| FPL1   | Fireplace 1 sto | B   | 1     | 5000.00    | 1998   |          | 82   |       | 0.00       | 4,100       |
| FEP  | Enclosed porc   | B   | 255   | 70.00      | 1998   |          | 82   |       | 0.00       | 12,000      |
| GAR  | Attached Gara   | B   | 536   | 40.00      | 1998   |          | 82   |       | 0.00       | 15,900      |
| BMT  | Basement-Unfi   | B   | 1,960 | 26.01      | 1998   |          | 82   |       | 0.00       | 36,100      |

| BUILDING SUB-AREA SUMMARY SECTION |                 |             |            |          |           |                |
|-----------------------------------|-----------------|-------------|------------|----------|-----------|----------------|
| Code                              | Description     | Living Area | Floor Area | Eff Area | Unit Cost | Undeprec Value |
| BAS                               | First Floor     | 1,960       | 1,960      | 1,960    | 300.72    | 589,407        |
| BMT                               | Basement Area   | 0           | 1,960      | 0        | 0.00      | 0              |
| FEP                               | Enclosed Porch  | 0           | 255        | 0        | 0.00      | 0              |
| GAR                               | Attached Garage | 0           | 536        | 0        | 0.00      | 0              |
| Ttl Gross Liv / Lease Area        |                 | 1,960       | 4,711      | 1,960    |           | 589,407        |

