

CONSTRUCTION DETAIL			CONSTRUCTION DETAIL (CONTINUED)		
Element	Cd	Description	Element	Cd	Description
Style	01	Ranch			
Model	01	Residential			
Grade:	C	Average			
Stories	1	1 Story			
Exterior Wall 1	14	Wood Shingle			
Exterior Wall 2					
RooF Structure	03	Gable/Hip			
RooF Cover	03	Asph/F Gls/Cmp			
Interior Wall 1	05	Drywall			
Interior Wall 2					
Interior Floor 1	12	Hardwood			
Interior Floor 2					
Heat Fuel	03	Gas			
Heat Type	05	Hot Water			
AC Type	03	Central			
Bedrooms	02	2 Bedrooms			
Full Baths	2				
Half Baths	0				
Extra Fixtures					
Total Rooms	6	6 Rooms			
Bath Style					
Kitchen Style					
Occupancy					
Usrflid 105					
Accessory Apt					
Foundation Alt	01	Poured Conc.			
Rms Prts					
Bath Split	20	2 Full-0 Half			

CONDO DATA				
Parcel Id		C	Ownr	0.0
			B	S
Adjust Type	Code	Description	Factor%	
Condo Flr				
Condo Unit				

COST / MARKET VALUATION		
Building Value New		457,730
Year Built		1981
Effective Year Built		1996
Depreciation Code		A
Remodel Rating		
Year Remodeled		
Depreciation %		18
Functional Obsol		0
External Obsol		0
Trend Factor		1
Condition		
Condition %		
Percent Good		82
RCNLD		375,300
Dep % Ovr		
Dep Ovr Comment		
Misc Imp Ovr		
Misc Imp Ovr Comment		
Cost to Cure Ovr		
Cost to Cure Ovr Comment		

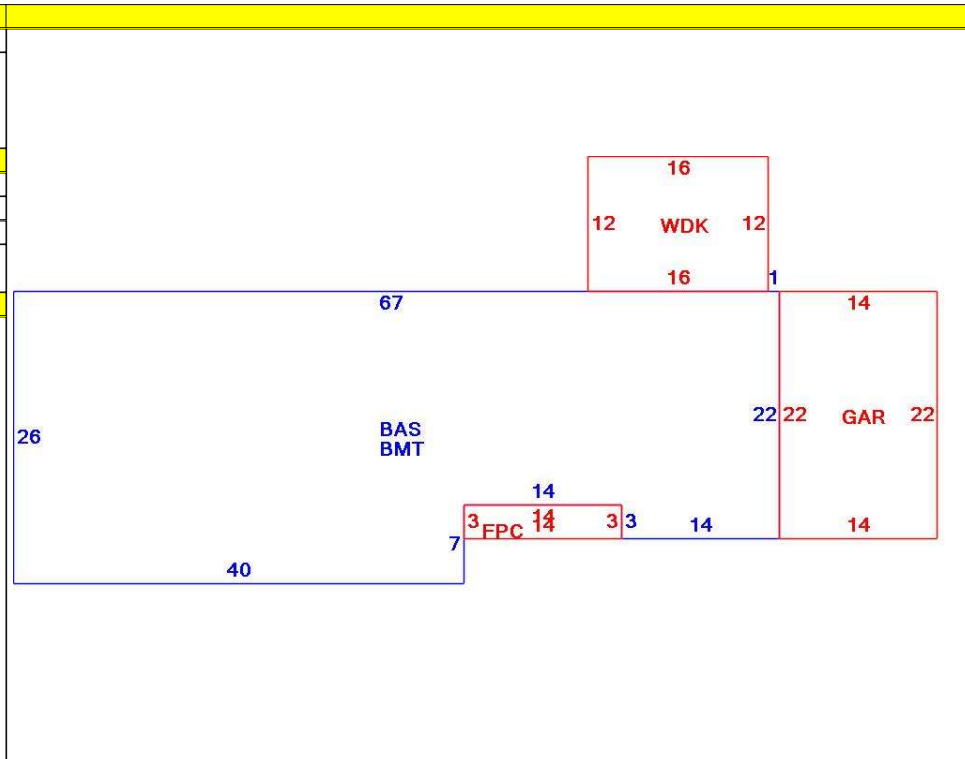

OB - OUTBUILDING & YARD ITEMS(L) / XF - BUILDING EXTRA FEATURES(B)										
Code	Description	L/B	Units	Unit Price	Yr Blt	Cond. Cd	% Gd	Grade	Grade Adj.	Appr. Value
FPL1	Fireplace 1 sto	B	1	5000.00	1998		82		0.00	4,100
WDC	Wood Decking	L	192	20.00	1998		58		0.00	2,700
FOPC	Open Prch-roo	B	42	55.00	1998		82		0.00	2,100
GAR	Attached Gara	B	308	40.00	1998		82		0.00	11,100
BMT	Basement-Unfi	B	1,614	26.01	1998		82		0.00	30,600

BUILDING SUB-AREA SUMMARY SECTION						
Code	Description	Living Area	Floor Area	Eff Area	Unit Cost	Undeprec Value
BAS	First Floor	1,614	1,614	1,614	283.60	457,730
BMT	Basement Area	0	1,614	0	0.00	0
FPC	Open Porch Conc. Floor	0	42	0	0.00	0
GAR	Attached Garage	0	308	0	0.00	0
WDK	Wood Deck	0	192	0	0.00	0
Ttl Gross Liv / Lease Area		1,614	3,770	1,614		457,730

