

CONSTRUCTION DETAIL			CONSTRUCTION DETAIL (CONTINUED)		
Element	Cd	Description	Element	Cd	Description
Style	06	Conventional			
Model	01	Residential			
Grade:	C+	Average Plus			
Stories	1.75	1 3/4 Stories			
Exterior Wall 1	14	Wood Shingle			
Exterior Wall 2	11	Clapboard			
Roof Structure	03	Gable/Hip			
Roof Cover	03	Asph/F Gls/Cmp			
Interior Wall 1	03	Plastered			
Interior Wall 2					
Interior Floor 1	12	Hardwood			
Interior Floor 2					
Heat Fuel	03	Gas			
Heat Type	05	Hot Water			
AC Type	01	None			
Bedrooms	05	5 Bedrooms			
Full Baths	3				
Half Baths	1				
Extra Fixtures					
Total Rooms	8	8 Rooms			
Bath Style					
Kitchen Style					
Occupancy					
Usrflid 105					
Accessory Apt					
Foundation Alt	09	Blk/Pour Ftgs			
Rms Prts					
Bath Split	31	3 Full-1 Half			
			Building Value New		823,905
			Year Built		1820
			Effective Year Built		1979
			Depreciation Code		A
			Remodel Rating		
			Year Remodeled		
			Depreciation %		31
			Functional Obsol		0
			External Obsol		0
			Trend Factor		1
			Condition		
			Condition %		
			Percent Good		69
			RCNLD		568,500
			Dep % Ovr		
			Dep Ovr Comment		
			Misc Imp Ovr		
			Misc Imp Ovr Comment		
			Cost to Cure Ovr		
			Cost to Cure Ovr Comment		

OB - OUTBUILDING & YARD ITEMS(L) / XF - BUILDING EXTRA FEATURES(B)										
Code	Description	L/B	Units	Unit Price	Yr Blt	Cond. Cd	% Gd	Grade	Grade Adj.	Appr. Value
FPL2	Fireplace 1.5 s	B	1	6000.00	1979		69		0.00	4,100
WDC	Wood Decking	L	128	20.00	1986		34		0.00	1,300
PAT2	Patio-Good	L	340	9.94	1986		67		0.00	2,300
GAR	Attached Gara	B	270	40.00	1979		69		0.00	8,500
UST	Utility Storage-	B	60	17.11	1979		69		0.00	600
WDC	Wood Deck w/	L	429	18.00	1986		34		0.00	2,500
FPL3	Fireplace 2 sto	B	1	7000.00	1979		69		0.00	4,800
PAT2	Patio-Good	L	120	9.94	1990		71		0.00	1,000
PRG1	Pergola-Avg	L	120	18.00	1990		42	C	1.00	900
GEN	Emergency Ge	L	1	5550.00	2013		88		0.00	4,900

BUILDING SUB-AREA SUMMARY SECTION						
Code	Description	Living Area	Floor Area	Eff Area	Unit Cost	Undeprec Value
BAS	First Floor	2,219	2,219	2,219	264.84	587,671
FHS	Half Story	429	858	429	132.42	113,615
GAR	Attached Garage	0	270	0	0.00	0
PRG	Pergola	0	120	0	0.00	0
PTO	Patio	0	460	0	0.00	0
TQS	Three Quarter Story	463	712	463	172.22	122,619
UST	Utility Enclosure	0	60	0	0.00	0
WDK	Wood Deck	0	557	0	0.00	0
Ttl Gross Liv / Lease Area		3,111	5,256	3,111		823,905

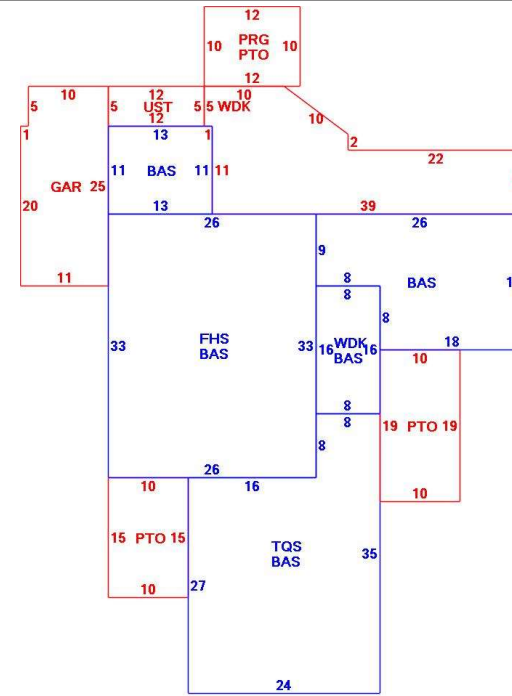

CURRENT OWNER		TOPO	UTILITIES	STRT / ROAD	LOCATION	CURRENT ASSESSMENT				801 FY2024 BARNSTABLE, MA VISION						
MURDOCH, WILLIAM A JR & SCANLO 760 SOUTH MAIN ST CENTERVILLE MA 02632		1 Level	2 Public Water	1 Paved		Description	Code	Assessed	Assessed							
			4 Gas			RESIDNTL	1010	601,100	601,100							
			6 Septic			RES LAND	1010	466,900	466,900							
SUPPLEMENTAL DATA						Total				1,068,000	1,068,000					
Alt Prcl ID		Split Zonin		Plan Ref. 69/37												
BID Parcel		ResExpt Q INFO:		Land Ct#												
#DL 1				#SR												
#DL 2				Life Estate												
GIS ID F_969168_2694644				PP STATU												
				Assoc Pid#												
RECORD OF OWNERSHIP		BK-VOL/PAGE	SALE DATE	Q/U	V/I	SALE PRIC	VC	PREVIOUS ASSESSMENTS (HISTORY)								
								Year	Code	Assessed	Year	Code	Assessed	Year	Code	Assessed
								2023	1010	509,100	2022	1010	419,300	2021	1010	333,200
									1010	328,600		1010	278,900		1010	253,600
															1010	12,900
								Total		837,700	Total		698,200	Total		599,700
EXEMPTIONS			OTHER ASSESSMENTS					This signature acknowledges a visit by a Data Collector or Assessor								
Year	Code	Description	Amount	Code	Description	Number	Amount	Comm Int								
		Total														
ASSESSING NEIGHBORHOOD								APPRAISED VALUE SUMMARY								
Nbhd	Nbhd Name		B	Tracing		Batch		Appraised Bldg. Value (Card)				568,500				
0110						CENVIL		Appraised Xf (B) Value (Bldg)				19,700				
								Appraised Ob (B) Value (Bldg)				12,900				
								Appraised Land Value (Bldg)				466,900				
								Special Land Value				0				
								Total Appraised Parcel Value				1,068,000				
								Valuation Method				C				
								Total Appraised Parcel Value				1,068,000				
BUILDING PERMIT RECORD								VISIT / CHANGE HISTORY								
Permit Id	Issue Date	Type	Description	Amount	Insp Date	% Comp	Date Comp	Comments	Date	Id	Type	Is	Cd	Purpost/Result		
LAND LINE VALUATION SECTION																
B	Use Code	Description	Zone	LA	Land Units	Unit Price	Size Adj	AC Disc	Site Index	Cond.	Nbhd.	Nbhd. Adj	Notes	Location Adjustmen	Adj Unit P	Land Value
Total Card Land Units					Parcel Total Land Area					Total Land Value						

