

CURRENT OWNER				TOPO	UTILITIES	STRT / ROAD	LOCATION	CURRENT ASSESSMENT				
ATTAR, GEORGE R & LAURIE C TRS ATTAR LIVING TRUST 12 BEACH PLUM WAY								Description	Code	Assessed	Assessed	801 FY2024 BARNSTABLE, MA
								RESIDNTL	1020	495,000	495,000	
HAMPTON NH 03842				<b>SUPPLEMENTAL DATA</b>								<b>VISION</b>
				Alt Prcl ID Split Zonin BID Parcel ResExpt Q NO APP: #DL 1 UNIT 3 #DL 2 GIS ID F_969694_2694240	Plan Ref. 369/29-31; 473/56 Land Ct# #SR Life Estate PP STATU A:Active Assoc Pid#					Total		

RECORD OF OWNERSHIP				BK-VOL/PAGE	SALE DATE	Q/U	V/I	SALE PRICE	VC	PREVIOUS ASSESSMENTS (HISTORY)									
ATTAR, GEORGE R & LAURIE C TRS	35995	139	09-22-2023	U	I			10	1V	Year	Code	Assessed	Year	Code	Assessed V	Year	Code	Assessed	
ATTAR, GEORGE R & LAURIE	32835	0150	04-17-2020	U	I			1,650,000	1V	2023	1020	407,500	2022	1020	337,200	2021	1020	334,800	
PIZZOTTI, DAVID S & HEATHER B	31240	0113	05-01-2018	Q	I			330,000	00								1020	2,400	
ROUGEAU, RICHARD N	15292	0125	06-24-2002	Q	I			260,000	00										
DALESSANDRO, VINCENT A & CAROLE B	4848	0298	12-15-1985	Q	I			132,500	00										
Total										407,500		Total		337,200		Total		337,200	

EXEMPTIONS				OTHER ASSESSMENTS				This signature acknowledges a visit by a Data Collector or Assessor												
Year	Code	Description	Amount	Code	Description	Number	Amount	Comm Int												
2020	N5C	NO RESIDENTIAL EXEMPTION	0.00																	
Total			0.00																	

ASSESSING NEIGHBORHOOD				APPRAISED VALUE SUMMARY															
Nbhd	Nbhd Name		B	Tracing		Batch													
0001						CENVIL													
NOTES																			
Appraised Bldg. Value (Card) 492,600																			
Appraised Xf (B) Value (Bldg) 0																			
Appraised Ob (B) Value (Bldg) 2,400																			
Appraised Land Value (Bldg) 0																			
Special Land Value 0																			
Total Appraised Parcel Value 495,000																			
Valuation Method C																			
Total Appraised Parcel Value 495,000																			

BUILDING PERMIT RECORD										VISIT / CHANGE HISTORY					
Permit Id	Issue Date	Type	Description	Amount	Insp Date	% Comp	Date Comp	Comments		Date	Id	Type	Is	Cd	Purpost/Result
										05-27-2020	WD			FR	Field Review
										07-27-2017	SR	02		03	Cycl Insp Comp
										08-13-2013	TP	03		16	In Office Review
										04-09-2013	TP	03		16	In Office Review

LAND LINE VALUATION SECTION																		
B	Use Code	Description	Zone	Dist	Land Type	Land Units	Unit Price	Size Adj	Site Index	Cond.	Nbhd.	Nbhd. Adj	Notes	Location Adjustmen	Adj Unit P	Land Value		
1	102U	Condominium M	CBD	3		0 SF	0.00	1.00000	5	1.00	0001	1.000		0.0000	0	0		
Total Card Land Units						0 SF	Parcel Total Land Area						0.00	Total Land Value				0

CONSTRUCTION DETAIL			CONSTRUCTION DETAIL (CONTINUED)		
Element	Cd	Description	Element	Cd	Description
Style	55	Condominium			
Model	05	Res Condo			
Bedrm Func	C+	Average Plus			
Stories	1	1 Story			
Occupancy	0				
Interior Wall 1	05	Drywall			
Interior Wall 2					
Interior Floor 1	20	Typical			
Interior Floor 2					
Heat Fuel	03	Gas			
Heat Type	09	Typical			
AC Type	01	None			
Bedrooms	01	1 Bedroom			
Full Baths	1	1 Full			
Half Baths	0				
Extra Fixtures					
Total Rooms	3	3 Rooms			
Bath Style					
Kitchen Style					
Master Deed L	588				
Bath Split	10	1 Full-0 Half			
Foundation	01	Poured Conc.			
AC Type Alt					
Sewer Occupan					
<b>CONDO DATA</b>					
Parcel Id	104231	C 0201	Ownr	16.	
	PORTLEDGE BY T	B 1	S 1		
Adjust Type	Code	Description	Factor%		
Condo Flr	1FU	FIRST FLOOR	100		
Condo Unit	MKT0	MKT0	100		
<b>COST / MARKET VALUATION</b>					
Building Value New		608,159			
Year Built		1920			
Effective Year Built		1994			
Depreciation Code		G			
Remodel Rating					
Year Remodeled					
Depreciation %		19			
Functional Obsol		0			
External Obsol		0			
Trend Factor		1			
Condition					
Condition %					
Percent Good		81			
Cns Sect Rcnd		492,600			
Dep % Ovr					
Dep Ovr Comment					
Misc Imp Ovr					
Misc Imp Ovr Comment					
Cost to Cure Ovr					
Cost to Cure Ovr Comment					

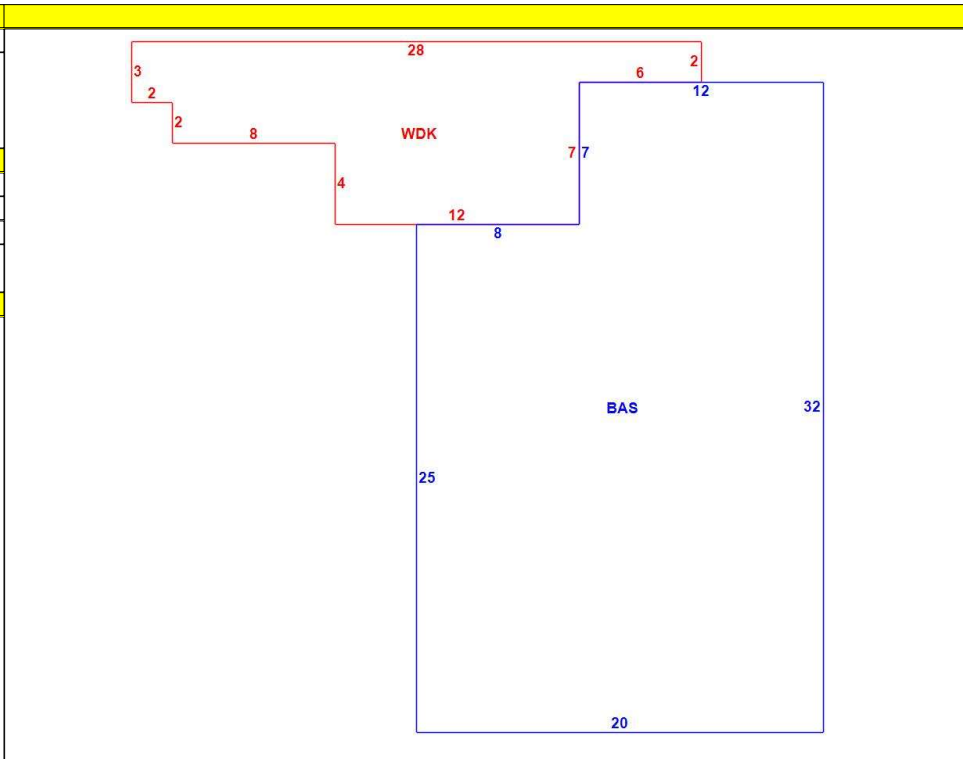

**OB - OUTBUILDING & YARD ITEMS(L) / XF - BUILDING EXTRA FEATURES(B)**

Code	Description	L/B	Units	Unit Price	Yr Blt	Cond. Cd	% Gd	Grade	Grade Adj.	Appr. Value
WDC	Wood Decking	L	166	20.00	1997		56		0.00	2,400

**BUILDING SUB-AREA SUMMARY SECTION**

Code	Description	Living Area	Floor Area	Eff Area	Unit Cost	Undeprec Value
BAS	First Floor	584	584	584	1,041.37	608,159
WDC	Wood Deck	0	166	0	0.00	0
Ttl Gross Liv / Lease Area		584	750	584		608,159

