

| CURRENT OWNER   |  | TOPO        | UTILITIES      | STRT / ROAD      | LOCATION     | CURRENT ASSESSMENT |      |           |           | 801<br>FY2024<br>BARNSTABLE, MA<br><br><b>VISION</b> |           |
|---|--|-------------|----------------|------------------|--------------|--------------------|------|-----------|-----------|--|-----------|
| GROSSMAN, BARBARA J TR<br>SUE-NAN TRUST<br>59 ORCHARD HILL DRIVE<br><br>SHARON MA 02067 |  | 1 Level     | 2 Public Water | 1 Paved          | 7 Waterfront | Description        | Code | Assessed  | Assessed  |  |           |
|   |  |             | 4 Gas          |                  | 1 Excel View | RESIDNTL           | 1010 | 997,600   | 997,600   |  |           |
|   |  |             | 6 Septic       |                  |              | RES LAND           | 1010 | 1,923,600 | 1,923,600 |  |           |
| <b>SUPPLEMENTAL DATA</b>  |  |             |                |                  |              | Total              |      |           |           | 2,921,200  | 2,921,200 |
| Alt Prcl ID   |  | Split Zonin |                | Plan Ref.        |              |                    |      |           |           |  |           |
| BID Parcel  |  | ResExpt Q   |                | Land Ct# 16409-A |              |                    |      |           |           |  |           |
| #DL 1 LOT A   |  | #DL 2       |                | #SR              |              |                    |      |           |           |  |           |
| GIS ID F_970046_2694409   |  | Assoc Pid#  |                | Life Estate      |              |                    |      |           |           |  |           |
|   |  |             |                | PP STATU         |              |                    |      |           |           |  |           |

| RECORD OF OWNERSHIP               |  | BK-VOL/PAGE | SALE DATE | Q/U        | V/I | SALE PRIC | VC      | PREVIOUS ASSESSMENTS (HISTORY) |           |      |           |           |      |          |           |      |          |
|-----------------------------------|--|-------------|-----------|------------|-----|-----------|---------|--------------------------------|-----------|------|-----------|-----------|------|----------|-----------|------|----------|
| GROSSMAN, BARBARA J TR            |  | C138205     | 0         | 09-15-1995 | U   | I         | 762,500 |                                | Year      | Code | Assessed  | Year      | Code | Assessed | Year      | Code | Assessed |
| BORNSTEIN, STUART A TR            |  | C122580     | 0         | 01-15-1991 | U   | I         | 1       | B                              | 2023      | 1010 | 854,900   | 2022      | 1010 | 712,800  | 2021      | 1010 | 609,000  |
| NICKULAS, LARRY & BORNSTEIN, STUA |  | C118395     | 0         | 09-15-1989 | U   | I         | 100,000 | N                              |           | 1010 | 1,748,700 |           | 1010 | 984,400  |           | 1010 | 958,500  |
| GONSALVES, JOAN M                 |  | #D48217     | 0         | 04-24-1989 | U   |           | 0       |                                |           |      | 0         |           |      | 0        |           | 1010 | 47,800   |
| MARINO, ERNEST & GONSALVES, JOAN  |  | C75945      | 0         | 10-18-1978 | U   |           | 0       |                                | Total     |      |           | Total     |      |          | Total     |      |          |
|                                   |  |             |           |            |     |           |         |                                | 2,603,600 |      |           | 1,697,200 |      |          | 1,615,300 |      |          |

| EXEMPTIONS |      |             |        | OTHER ASSESSMENTS |             |        |        | This signature acknowledges a visit by a Data Collector or Assessor |  |  |  |  |  |  |  |  |  |  |
|------------|------|-------------|--------|-------------------|-------------|--------|--------|---|--|--|--|--|--|--|--|--|--|--|
| Year       | Code | Description | Amount | Code              | Description | Number | Amount | Comm Int  |  |  |  |  |  |  |  |  |  |  |
|            |      |             | Total  | 0.00              |             |        |        |   |  |  |  |  |  |  |  |  |  |  |

| ASSESSING NEIGHBORHOOD |           |   |         | APPRAISED VALUE SUMMARY |  |  |  |  |                               |                              |         |
|------------------------|-----------|---|---------|-------------------------|--|--|--|--|-------------------------------|------------------------------|---------|
| Nbhd                   | Nbhd Name | B | Tracing | Batch                   |  |  |  |  |                               |                              |         |
| 0118                   |           |   |         | CENVIL                  |  |  |  |  |                               | Appraised Bldg. Value (Card) | 872,400 |
|                        |           |   |         |                         |  |  |  |  | Appraised Xf (B) Value (Bldg) | 75,900                       |         |
|                        |           |   |         |                         |  |  |  |  | Appraised Ob (B) Value (Bldg) | 49,300                       |         |
|                        |           |   |         |                         |  |  |  |  | Appraised Land Value (Bldg)   | 1,923,600                    |         |
|                        |           |   |         |                         |  |  |  |  | Special Land Value            | 0                            |         |
|                        |           |   |         |                         |  |  |  |  | Total Appraised Parcel Value  | 2,921,200                    |         |
|                        |           |   |         |                         |  |  |  |  | Valuation Method              | C                            |         |
|                        |           |   |         |                         |  |  |  |  | Total Appraised Parcel Value  | 2,921,200                    |         |

| NOTES     |            |      |                |         |            |        |            |           |  | VISIT / CHANGE HISTORY |    |      |    |    |                            |  |  |
|-----------|------------|------|----------------|---------|------------|--------|------------|-----------|--|------------------------|----|------|----|----|----------------------------|--|--|
| Permit Id | Issue Date | Type | Description    | Amount  | Insp Date  | % Comp | Date Comp  | Comments  |  | Date                   | Id | Type | Is | Cd | Purpost/Result             |  |  |
| 16-2998   | 10-12-2016 | 835  | Sid/Wind/Roof/ | 12,000  |            | 100    |            | reside    |  | 01-04-2023             | BM | 03   |    | 16 | In Office Review           |  |  |
| 15465     | 05-28-1996 | AD   | Addition       | 2,500   |            | 100    | 01-01-1997 | PORCH     |  | 05-27-2020             | WD |      |    | FR | Field Review               |  |  |
| 12754     | 01-16-1996 | AD   | Addition       | 15,000  |            | 100    | 01-01-1997 | BSMT      |  | 07-29-2019             | CK | 22   |    | 22 | Change of Address          |  |  |
| B33621    | 03-01-1990 | DE   | Demolish       | 0       | 01-15-1991 | 100    |            | CE DWELL. |  | 09-12-2016             | KM | 02   |    | 03 | Cycl Insp Comp             |  |  |
| B33611    | 03-01-1990 | DW   | Dwelling       | 100,000 | 01-15-1994 | 100    |            | CE 2 STOR |  | 11-07-2008             | PT | 02   |    | 14 | Cyclical Inspection        |  |  |
|           |            |      |                |         |            |        |            |           |  | 06-26-2001             | PT | 01   |    | 00 | Meas/Listed-Interior Acces |  |  |
|           |            |      |                |         |            |        |            |           |  | 08-21-1998             | LK |      |    |    |                            |  |  |

| LAND LINE VALUATION SECTION |          |                |      |    |            |            |                        |         |            |       |       |           |                  |                    |            |            |           |
|-----------------------------|----------|----------------|------|----|------------|------------|------------------------|---------|------------|-------|-------|-----------|------------------|--------------------|------------|------------|-----------|
| B                           | Use Code | Description    | Zone | LA | Land Units | Unit Price | Size Adj               | AC Disc | Site Index | Cond. | Nbhd. | Nbhd. Adj | Notes            | Location Adjustmen | Adj Unit P | Land Value |           |
| 1                           | 1010     | Single Fam M-0 | CBD  | 3  | 0.400      | AC         | 176,344.00             | 2.18159 | 1.0000     | 5     | 1.00  | 0118      | 12.500           |                    | 1.0000     | 4,808,900  | 1,923,600 |
| Total Card Land Units       |          |                |      |    | 0.40       | AC         | Parcel Total Land Area |         |            |       |       | 0.40      | Total Land Value |                    |            |            | 1,923,600 |

| CONSTRUCTION DETAIL |    |                | CONSTRUCTION DETAIL (CONTINUED) |      |             |
|---------------------|----|----------------|---------------------------------|------|-------------|
| Element             | Cd | Description    | Element                         | Cd   | Description |
| Style               | 03 | Colonial       |                                 |      |             |
| Model               | 01 | Residential    |                                 |      |             |
| Grade:              | B+ | Custom Plus    |                                 |      |             |
| Stories             | 2  | 2 Stories      |                                 |      |             |
| Exterior Wall 1     | 14 | Wood Shingle   |                                 |      |             |
| Exterior Wall 2     |    |                |                                 |      |             |
| RooF Structure      | 03 | Gable/Hip      |                                 |      |             |
| RooF Cover          | 03 | Asph/F Gls/Cmp |                                 |      |             |
| Interior Wall 1     | 03 | Plastered      |                                 |      |             |
| Interior Wall 2     |    |                |                                 |      |             |
| Interior Floor 1    | 12 | Hardwood       |                                 |      |             |
| Interior Floor 2    |    |                |                                 |      |             |
| Heat Fuel           | 03 | Gas            |                                 |      |             |
| Heat Type           | 04 | Hot Air        |                                 |      |             |
| AC Type             | 03 | Central        |                                 |      |             |
| Bedrooms            | 04 | 4 Bedrooms     |                                 |      |             |
| Full Baths          | 4  |                |                                 |      |             |
| Half Baths          | 0  |                |                                 |      |             |
| Extra Fixtures      |    |                |                                 |      |             |
| Total Rooms         | 10 | 10 Rooms       |                                 |      |             |
| Bath Style          | 02 | Average        |                                 |      |             |
| Kitchen Style       | 02 | Modernized     |                                 |      |             |
| Occupancy           |    |                |                                 |      |             |
| Usrflid 105         |    |                |                                 |      |             |
| Accessory Apt       |    |                |                                 |      |             |
| Foundation Alt      | 01 | Poured Conc.   |                                 |      |             |
| Rms Prts            |    |                |                                 |      |             |
| Bath Split          | 40 | 4 Full-0 Half  |                                 |      |             |
|                     |    |                | <b>CONDO DATA</b>               |      |             |
|                     |    |                | Parcel Id                       |      | C           |
|                     |    |                | Owne 0.0                        |      |             |
|                     |    |                | Adjust Type                     | Code | Description |
|                     |    |                | Condo Flr                       |      |             |
|                     |    |                | Condo Unit                      |      |             |
|                     |    |                | <b>COST / MARKET VALUATION</b>  |      |             |
|                     |    |                | Building Value New              |      | 1,014,460   |
|                     |    |                | Year Built                      |      | 1990        |
|                     |    |                | Effective Year Built            |      | 2001        |
|                     |    |                | Depreciation Code               |      | A           |
|                     |    |                | Remodel Rating                  |      |             |
|                     |    |                | Year Remodeled                  |      |             |
|                     |    |                | Depreciation %                  |      | 14          |
|                     |    |                | Functional Obsol                |      | 0           |
|                     |    |                | External Obsol                  |      | 0           |
|                     |    |                | Trend Factor                    |      | 1           |
|                     |    |                | Condition                       |      |             |
|                     |    |                | Condition %                     |      |             |
|                     |    |                | Percent Good                    |      | 86          |
|                     |    |                | RCNLD                           |      | 872,400     |
|                     |    |                | Dep % Ovr                       |      |             |
|                     |    |                | Dep Ovr Comment                 |      |             |
|                     |    |                | Misc Imp Ovr                    |      |             |
|                     |    |                | Misc Imp Ovr Comment            |      |             |
|                     |    |                | Cost to Cure Ovr                |      |             |
|                     |    |                | Cost to Cure Ovr Comment        |      |             |

| OB - OUTBUILDING & YARD ITEMS(L) / XF - BUILDING EXTRA FEATURES(B) |                 |     |       |            |        |          |      |       |            |             |
|--|-----------------|-----|-------|------------|--------|----------|------|-------|------------|-------------|
| Code   | Description     | L/B | Units | Unit Price | Yr Blt | Cond. Cd | % Gd | Grade | Grade Adj. | Appr. Value |
| FPL2   | Fireplace 1.5 s | B   | 1     | 6000.00    | 2003   |          | 86   |       | 0.00       | 5,200       |
| FPO  | Ext FP Openin   | B   | 1     | 2000.00    | 2003   |          | 86   |       | 0.00       | 1,700       |
| BGAR   | Bsmt Garage     | B   | 1     | 2326.00    | 2003   |          | 86   |       | 0.00       | 2,000       |
| BFA  | Bsmt Fin-Avg    | B   | 1,100 | 17.36      | 2003   |          | 86   |       | 0.00       | 16,400      |
| DKLT   | Dock-Light      | L   | 1     | 60000.00   | 1997   |          | 56   |       | 0.00       | 33,600      |
| WDC  | Wood Decking    | L   | 496   | 20.00      | 2006   |          | 74   |       | 0.00       | 6,900       |
| PAT1   | Patio- Average  | L   | 836   | 5.89       | 2006   |          | 87   |       | 0.00       | 3,900       |
| FOP  | Open Porch-ro   | B   | 440   | 55.00      | 2003   |          | 86   |       | 0.00       | 14,700      |
| BMT  | Basement-Unfi   | B   | 1,840 | 26.01      | 2003   |          | 86   |       | 0.00       | 35,900      |
| PAT1   | Patio- Average  | L   | 625   | 5.89       | 2016   |          | 97   |       | 0.00       | 3,400       |

| BUILDING SUB-AREA SUMMARY SECTION |               |             |            |          |           |                |
|-----------------------------------|---------------|-------------|------------|----------|-----------|----------------|
| Code                              | Description   | Living Area | Floor Area | Eff Area | Unit Cost | Undeprec Value |
| BAS                               | First Floor   | 1,688       | 1,688      | 1,688    | 304.09    | 513,312        |
| BMT                               | Basement Area | 0           | 1,840      | 0        | 0.00      | 0              |
| FOP                               | Open Porch    | 0           | 440        | 0        | 0.00      | 0              |
| FUS                               | Upper Story   | 1,648       | 1,648      | 1,648    | 304.09    | 501,148        |
| WDK                               | Wood Deck     | 0           | 496        | 0        | 0.00      | 0              |
| Ttl Gross Liv / Lease Area        |               | 3,336       | 6,112      | 3,336    |           | 1,014,460      |

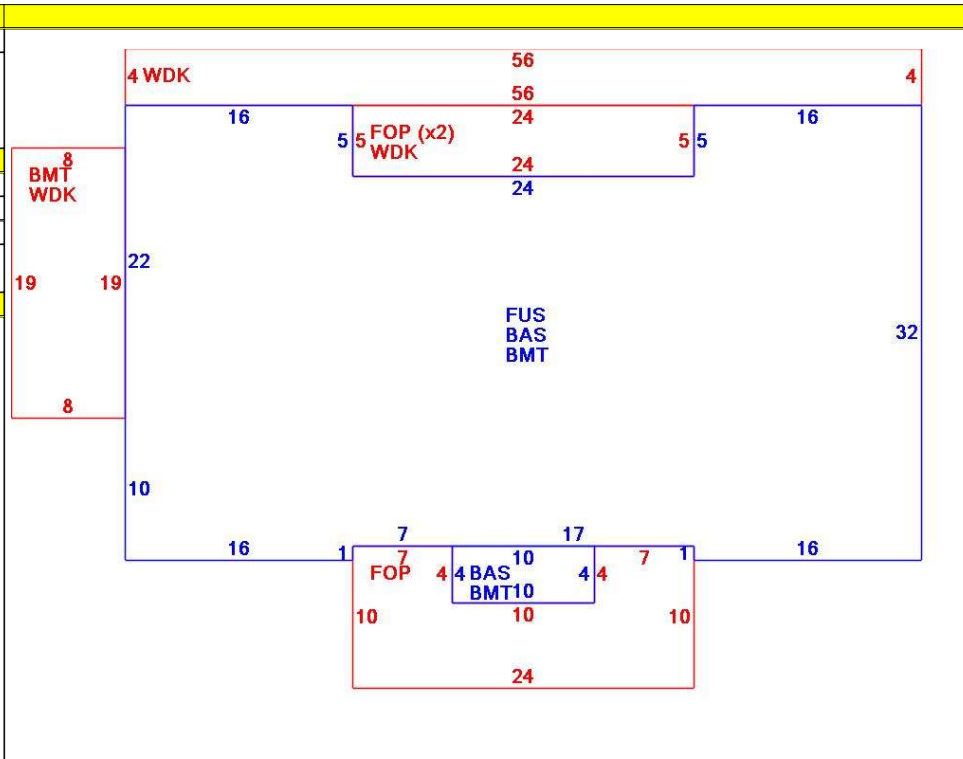

| CURRENT OWNER   |  | TOPO    | UTILITIES        | STRT / ROAD | LOCATION     | CURRENT ASSESSMENT        |      |           |           | 801<br>FY2024<br>BARNSTABLE, MA |
|---|--|---------|------------------|-------------|--------------|---------------------------|------|-----------|-----------|---------------------------------|
| GROSSMAN, BARBARA J TR<br>SUE-NAN TRUST<br>59 ORCHARD HILL DRIVE<br><br>SHARON MA 02067 |  | 1 Level | 2 Public Water   | 1 Paved     | 7 Waterfront | Description               | Code | Assessed  | Assessed  |                                 |
|   |  |         | 4 Gas            |             | 1 Excel View | RESIDNTL                  | 1010 | 997,600   | 997,600   |                                 |
|   |  |         | 6 Septic         |             |              | RES LAND                  | 1010 | 1,923,600 | 1,923,600 |                                 |
| <b>SUPPLEMENTAL DATA</b>  |  |         |                  |             |              |                           |      |           |           | <b>VISION</b>                   |
| Alt Prcl ID   |  |         | Plan Ref.        |             |              |                           |      |           |           |                                 |
| Split Zonin   |  |         | Land Ct# 16409-A |             |              |                           |      |           |           |                                 |
| BID Parcel  |  |         | #SR              |             |              |                           |      |           |           |                                 |
| ResExpt Q   |  |         | Life Estate      |             |              |                           |      |           |           |                                 |
| #DL 1 LOT A   |  |         | PP STATU         |             |              |                           |      |           |           |                                 |
| #DL 2   |  |         | Assoc Pid#       |             |              |                           |      |           |           |                                 |
| GIS ID F_970046_2694409   |  |         |                  |             |              | Total 2,921,200 2,921,200 |      |           |           |                                 |

| RECORD OF OWNERSHIP |  | BK-VOL/PAGE | SALE DATE | Q/U | V/I | SALE PRIC | VC | PREVIOUS ASSESSMENTS (HISTORY) |      |           |       |      |           |
|---------------------|--|-------------|-----------|-----|-----|-----------|----|--------------------------------|------|-----------|-------|------|-----------|
|                     |  |             |           |     |     |           |    | Year                           | Code | Assessed  | Year  | Code | Assessed  |
|                     |  |             |           |     |     |           |    | 2023                           | 1010 | 854,900   | 2022  | 1010 | 712,800   |
|                     |  |             |           |     |     |           |    |                                | 1010 | 1,748,700 |       | 1010 | 984,400   |
|                     |  |             |           |     |     |           |    |                                |      |           | 2021  | 1010 | 609,000   |
|                     |  |             |           |     |     |           |    |                                |      |           |       | 1010 | 958,500   |
|                     |  |             |           |     |     |           |    |                                |      |           |       | 1010 | 47,800    |
|                     |  |             |           |     |     |           |    | Total                          |      | 2,603,600 | Total |      | 1,697,200 |
|                     |  |             |           |     |     |           |    | Total                          |      |           | Total |      | 1,615,300 |

| EXEMPTIONS |      |             | OTHER ASSESSMENTS |      |             |        |        | This signature acknowledges a visit by a Data Collector or Assessor |  |  |  |  |
|------------|------|-------------|-------------------|------|-------------|--------|--------|---|--|--|--|--|
| Year       | Code | Description | Amount            | Code | Description | Number | Amount | Comm Int  |  |  |  |  |
|            |      |             |                   |      |             |        |        |   |  |  |  |  |
| Total      |      |             |                   |      |             |        |        |   |  |  |  |  |

| ASSESSING NEIGHBORHOOD |           |   |         |        |  | APPRAISED VALUE SUMMARY       |           |  |  |
|------------------------|-----------|---|---------|--------|--|-------------------------------|-----------|--|--|
| Nbhd                   | Nbhd Name | B | Tracing | Batch  |  | Appraised Bldg. Value (Card)  | 872,400   |  |  |
| 0118                   |           |   |         | CENVIL |  | Appraised Xf (B) Value (Bldg) | 75,900    |  |  |
|                        |           |   |         |        |  | Appraised Ob (B) Value (Bldg) | 49,300    |  |  |
|                        |           |   |         |        |  | Appraised Land Value (Bldg)   | 1,923,600 |  |  |
|                        |           |   |         |        |  | Special Land Value            | 0         |  |  |
|                        |           |   |         |        |  | Total Appraised Parcel Value  | 2,921,200 |  |  |
|                        |           |   |         |        |  | Valuation Method              | C         |  |  |
|                        |           |   |         |        |  | Total Appraised Parcel Value  | 2,921,200 |  |  |

| NOTES     |            |      |             |        |           |        |           |          |  | VISIT / CHANGE HISTORY |    |      |    |    |                |
|-----------|------------|------|-------------|--------|-----------|--------|-----------|----------|--|------------------------|----|------|----|----|----------------|
| Permit Id | Issue Date | Type | Description | Amount | Insp Date | % Comp | Date Comp | Comments |  | Date                   | Id | Type | Is | Cd | Purpost/Result |
|           |            |      |             |        |           |        |           |          |  |                        |    |      |    |    |                |

| BUILDING PERMIT RECORD |            |      |             |        |           |        |           |          |  |      |    |      |    | VISIT / CHANGE HISTORY |                |  |  |
|------------------------|------------|------|-------------|--------|-----------|--------|-----------|----------|--|------|----|------|----|------------------------|----------------|--|--|
| Permit Id              | Issue Date | Type | Description | Amount | Insp Date | % Comp | Date Comp | Comments |  | Date | Id | Type | Is | Cd                     | Purpost/Result |  |  |
|                        |            |      |             |        |           |        |           |          |  |      |    |      |    |                        |                |  |  |

| LAND LINE VALUATION SECTION |          |             |      |    |                        |            |          |         |            |                  |       |           |       |                    |            |            |  |
|-----------------------------|----------|-------------|------|----|------------------------|------------|----------|---------|------------|------------------|-------|-----------|-------|--------------------|------------|------------|--|
| B                           | Use Code | Description | Zone | LA | Land Units             | Unit Price | Size Adj | AC Disc | Site Index | Cond.            | Nbhd. | Nbhd. Adj | Notes | Location Adjustmen | Adj Unit P | Land Value |  |
|                             |          |             |      |    |                        |            |          |         |            |                  |       |           |       |                    |            |            |  |
| Total Card Land Units       |          |             |      |    | Parcel Total Land Area |            |          |         |            | Total Land Value |       |           |       |                    |            |            |  |

| CONSTRUCTION DETAIL   |             |                |                                |            |             | CONSTRUCTION DETAIL (CONTINUED) |      |       |            |             |
|---|-------------|----------------|--------------------------------|------------|-------------|---------------------------------|------|-------|------------|-------------|
| Element   | Cd          | Description    | Element                        | Cd         | Description |                                 |      |       |            |             |
| Style   | 03          | Colonial       |                                |            |             |                                 |      |       |            |             |
| Model   | 01          | Residential    |                                |            |             |                                 |      |       |            |             |
| Grade:  | B+          | Custom Plus    |                                |            |             |                                 |      |       |            |             |
| Stories   | 2           | 2 Stories      |                                |            |             |                                 |      |       |            |             |
| Exterior Wall 1   | 14          | Wood Shingle   | <b>CONDO DATA</b>              |            |             |                                 |      |       |            |             |
| Exterior Wall 2   |             |                | Parcel Id                      |            | C           | Owne                            | 0.0  |       |            |             |
| Roof Structure  | 03          | Gable/Hip      |                                |            | B           | S                               |      |       |            |             |
| Roof Cover  | 03          | Asph/F Gls/Cmp | Adjust Type                    | Code       | Description | Factor%                         |      |       |            |             |
| Interior Wall 1   | 03          | Plastered      | Condo Flr                      |            |             |                                 |      |       |            |             |
| Interior Wall 2   |             |                | Condo Unit                     |            |             |                                 |      |       |            |             |
| Interior Floor 1  | 12          | Hardwood       | <b>COST / MARKET VALUATION</b> |            |             |                                 |      |       |            |             |
| Interior Floor 2  |             |                | Building Value New             |            |             |                                 |      |       |            |             |
| Heat Fuel   | 03          | Gas            | Year Built                     |            |             |                                 |      |       |            |             |
| Heat Type   | 04          | Hot Air        | Effective Year Built           |            |             |                                 |      |       |            |             |
| AC Type   | 03          | Central        | Depreciation Code              |            |             |                                 |      |       |            |             |
| Bedrooms  | 04          | 4 Bedrooms     | Remodel Rating                 |            |             |                                 |      |       |            |             |
| Full Baths  | 4           |                | Year Remodeled                 |            |             |                                 |      |       |            |             |
| Half Baths  | 0           |                | Depreciation %                 |            |             |                                 |      |       |            |             |
| Extra Fixtures  |             |                | Functional Obsol               |            |             |                                 |      |       |            |             |
| Total Rooms   | 10          | 10 Rooms       | External Obsol                 |            |             |                                 |      |       |            |             |
| Bath Style  | 02          | Average        | Trend Factor                   |            |             |                                 |      |       |            |             |
| Kitchen Style   | 02          | Modernized     | Condition                      |            |             |                                 |      |       |            |             |
| Occupancy   |             |                | Condition %                    |            |             |                                 |      |       |            |             |
| Usrflid 105   |             |                | Percent Good                   |            |             |                                 |      |       |            |             |
| Accessory Apt   |             |                | RCNLD                          |            |             |                                 |      |       |            |             |
| Foundation Alt  | 01          | Poured Conc.   | Dep % Ovr                      |            |             |                                 |      |       |            |             |
| Rms Prts  |             |                | Dep Ovr Comment                |            |             |                                 |      |       |            |             |
| Bath Split  | 40          | 4 Full-0 Half  | Misc Imp Ovr                   |            |             |                                 |      |       |            |             |
|   |             |                | Misc Imp Ovr Comment           |            |             |                                 |      |       |            |             |
|   |             |                | Cost to Cure Ovr               |            |             |                                 |      |       |            |             |
|   |             |                | Cost to Cure Ovr Comment       |            |             |                                 |      |       |            |             |
| <b>OB - OUTBUILDING &amp; YARD ITEMS(L) / XF - BUILDING EXTRA FEATURES(B)</b> |             |                |                                |            |             |                                 |      |       |            |             |
| Code  | Description | L/B            | Units                          | Unit Price | Yr Blt      | Cond. Cd                        | % Gd | Grade | Grade Adj. | Appr. Value |
| SHED  | Shed        | L              | 112                            | 18.00      | 2006        |                                 | 74   |       | 0.00       | 1,500       |
| <b>BUILDING SUB-AREA SUMMARY SECTION</b>                                      |             |                |                                |            |             |                                 |      |       |            |             |
| Code  | Description | Living Area    | Floor Area                     | Eff Area   | Unit Cost   | Undeprec Value                  |      |       |            |             |
|   |             |                |                                |            |             |                                 |      |       |            |             |
| Ttl Gross Liv / Lease Area  |             |                |                                |            |             |                                 |      |       |            |             |