

| CURRENT OWNER | | TOPO | | UTILITIES | | STRT / ROAD | | LOCATION | | CURRENT ASSESSMENT | | | | 801 FY2024 BARNSTABLE, MA VISION | | | | | | | |
|---|------------|------------------|-------------|-------------------|--------------|-------------|------------------------|---|------------|-------------------------------|---------|--------------------------------|------------------|--|-----------------------|--------------------------------|--------------|--------------------|--------------------|---------|----------|
| WILBUR, JOHN D & DEBORAH A 70 BAY LANE CENTERVILLE MA 02632 | | 1 | Level | 6 | Septic | 1 | Paved | | | Description | Code | Assessed | Assessed | | | RESIDENTL RES LAND | 1010 1010 | 498,600 485,200 | 498,600 485,200 | | |
| | | | | 4 | Gas | | | | | | | | | | | | | | | | |
| | | | | 2 | Public Water | | | | | | | | | | | | | | | | |
| SUPPLEMENTAL DATA | | | | | | | | | | Total | | | | 983,800 | 983,800 | | | | | | |
| Alt Prcl ID | | Split Zonin | | Plan Ref. | | 334/94 | | | | | | | | | | | | | | | |
| BID Parcel | | ResExpt Q | | Land Ct# | | #SR | | | | | | | | | | | | | | | |
| #DL 1 | | LOT 4 | | Life Estate | | PP STATU | | | | | | | | | | | | | | | |
| #DL 2 | | | | Assoc Pid# | | | | | | | | | | | | | | | | | |
| GIS ID | | F_968785_2695085 | | | | | | | | | | | | | | | | | | | |
| RECORD OF OWNERSHIP | | | | BK-VOL/PAGE | | SALE DATE | | Q/U | | V/I | | SALE PRIC | | VC | | PREVIOUS ASSESSMENTS (HISTORY) | | | | | |
| WILBUR, JOHN D & DEBORAH A | | | | 23125 | 0005 | 08-28-2008 | U | I | | | 1 | 1A | Year | Code | Assessed | Year | Code | Assessed | Year | Code | Assessed |
| WILBUR, JOHN D | | | | 22910 | 0094 | 05-15-2008 | U | I | | | 498,250 | 1 | 2023 | 1010 | 445,900 | 2022 | 1010 | 340,500 | 2021 | 1010 | 286,500 |
| BALCKE, STEPHANIE W | | | | 10640 | 0328 | 03-07-1997 | U | I | | | 0 | 1F | | 1010 | 341,500 | | 1010 | 289,800 | | 1010 | 263,500 |
| BALCKE, EDWARD C & STEPHANIE W | | | | 3264 | 0209 | 04-06-1981 | Q | | | | 35,000 | U | | | | | | | | 1010 | 4,400 |
| | | | | | | | | | | | | Total | | 787,400 | Total | | 630,300 | Total | | 554,400 | |
| EXEMPTIONS | | | | OTHER ASSESSMENTS | | | | This signature acknowledges a visit by a Data Collector or Assessor | | | | | | | | | | | | | |
| Year | Code | Description | | Amount | | Code | Description | | Number | Amount | | Comm Int | | | | | | | | | |
| | | | | | | | | | | | | | | | | | | | | | |
| Total | | | | 0.00 | | | | | | | | | | | | | | | | | |
| ASSESSING NEIGHBORHOOD | | | | | | | | | | | | APPRAISED VALUE SUMMARY | | | | | | | | | |
| Nbhd | | Nbhd Name | | B | | Tracing | | Batch | | Appraised Bldg. Value (Card) | | | | 457,000 | | | | | | | |
| 0110 | | | | | | | | CENVIL | | Appraised Xf (B) Value (Bldg) | | | | 31,400 | | | | | | | |
| | | | | | | | | | | | | Appraised Ob (B) Value (Bldg) | | | | 10,200 | | | | | |
| | | | | | | | | | | | | Appraised Land Value (Bldg) | | | | 485,200 | | | | | |
| | | | | | | | | | | | | Special Land Value | | | | 0 | | | | | |
| | | | | | | | | | | | | Total Appraised Parcel Value | | | | 983,800 | | | | | |
| | | | | | | | | | | | | Valuation Method | | | | C | | | | | |
| | | | | | | | | | | | | Total Appraised Parcel Value | | | | 983,800 | | | | | |
| BUILDING PERMIT RECORD | | | | | | | | | | | | VISIT / CHANGE HISTORY | | | | | | | | | |
| Permit Id | Issue Date | Type | Description | Amount | Insp Date | % Comp | Date Comp | Comments | | Date | Id | Type | Is | Cd | Purpost/Result | | | | | | |
| 19-2273 | 07-12-2019 | 822 | Insulation | 7,900 | 06-30-2020 | 100 | 06-30-2020 | Insulation | | 10-07-2021 | SR | 02 | | 03 | Cycl Insp Comp | | | | | | |
| 201002716 | 06-03-2010 | WD | Wood Deck | 10,000 | 02-14-2011 | 100 | 06-30-2011 | REPL 14 X 25 | | 05-14-2020 | WD | | | FR | Field Review | | | | | | |
| | | | | | | | | | | 08-10-2015 | JR | 03 | | 16 | In Office Review | | | | | | |
| | | | | | | | | | | 08-08-2014 | JR | 03 | | 16 | In Office Review | | | | | | |
| | | | | | | | | | | 02-18-2011 | RB | 03 | | 02 | Bldg Permit Completed | | | | | | |
| | | | | | | | | | | 02-14-2011 | MK | 02 | | 52 | New Construction | | | | | | |
| | | | | | | | | | | 11-18-2008 | PT | 02 | | 14 | Cyclical Inspection | | | | | | |
| LAND LINE VALUATION SECTION | | | | | | | | | | | | | | | | | | | | | |
| B | Use Code | Description | Zone | LA | Land Units | Unit Price | Size Adj | AC Disc | Site Index | Cond. | Nbhd. | Nbhd. Adj | Notes | Location Adjustmen | Adj Unit P | Land Value | | | | | |
| 1 | 1010 | Single Fam M-0 | RD- | 3 | 0.480 | AC | 176,344.00 | 1.84893 | 1.0000 | 5 | 1.00 | 0110 | 3.100 | | 1.0000 | 1,010,750 | 485,200 | | | | |
| Total Card Land Units | | | | | 0.48 | AC | Parcel Total Land Area | | | | | 0.48 | Total Land Value | | | | 485,200 | | | | |

| CONSTRUCTION DETAIL | | | CONSTRUCTION DETAIL (CONTINUED) | | |
|---------------------|------|----------------|---------------------------------|----|-------------|
| Element | Cd | Description | Element | Cd | Description |
| Style | 04 | Cape Cod | | | |
| Model | 01 | Residential | | | |
| Grade: | C+ | Average Plus | | | |
| Stories | 1.75 | 1 3/4 Stories | | | |
| Exterior Wall 1 | 14 | Wood Shingle | | | |
| Exterior Wall 2 | 11 | Clapboard | | | |
| RooF Structure | 03 | Gable/Hip | | | |
| RooF Cover | 03 | Asph/F Gls/Cmp | | | |
| Interior Wall 1 | 03 | Plastered | | | |
| Interior Wall 2 | | | | | |
| Interior Floor 1 | 12 | Hardwood | | | |
| Interior Floor 2 | 14 | Carpet | | | |
| Heat Fuel | 03 | Gas | | | |
| Heat Type | 05 | Hot Water | | | |
| AC Type | 03 | Central | | | |
| Bedrooms | 03 | 3 Bedrooms | | | |
| Full Baths | 2 | | | | |
| Half Baths | 0 | | | | |
| Extra Fixtures | | | | | |
| Total Rooms | 6 | 6 Rooms | | | |
| Bath Style | | | | | |
| Kitchen Style | | | | | |
| Occupancy | | | | | |
| Usrflid 105 | | | | | |
| Accessory Apt | | | | | |
| Foundation Alt | 01 | Poured Conc. | | | |
| Rms Prts | | | | | |
| Bath Split | 20 | 2 Full-0 Half | | | |

| CONDO DATA | | | | |
|-------------|------|-------------|---------|----------|
| Parcel Id | | C | | Ownr 0.0 |
| Adjust Type | Code | Description | Factor% | |
| Condo Flr | | | | |
| Condo Unit | | | | |

| COST / MARKET VALUATION | |
|--------------------------|---------|
| Building Value New | 531,342 |
| Year Built | 1981 |
| Effective Year Built | 2001 |
| Depreciation Code | G |
| Remodel Rating | |
| Year Remodeled | |
| Depreciation % | 14 |
| Functional Obsol | 0 |
| External Obsol | 0 |
| Trend Factor | 1 |
| Condition | |
| Condition % | |
| Percent Good | 86 |
| RCNLD | 457,000 |
| Dep % Ovr | |
| Dep Ovr Comment | |
| Misc Imp Ovr | |
| Misc Imp Ovr Comment | |
| Cost to Cure Ovr | |
| Cost to Cure Ovr Comment | |

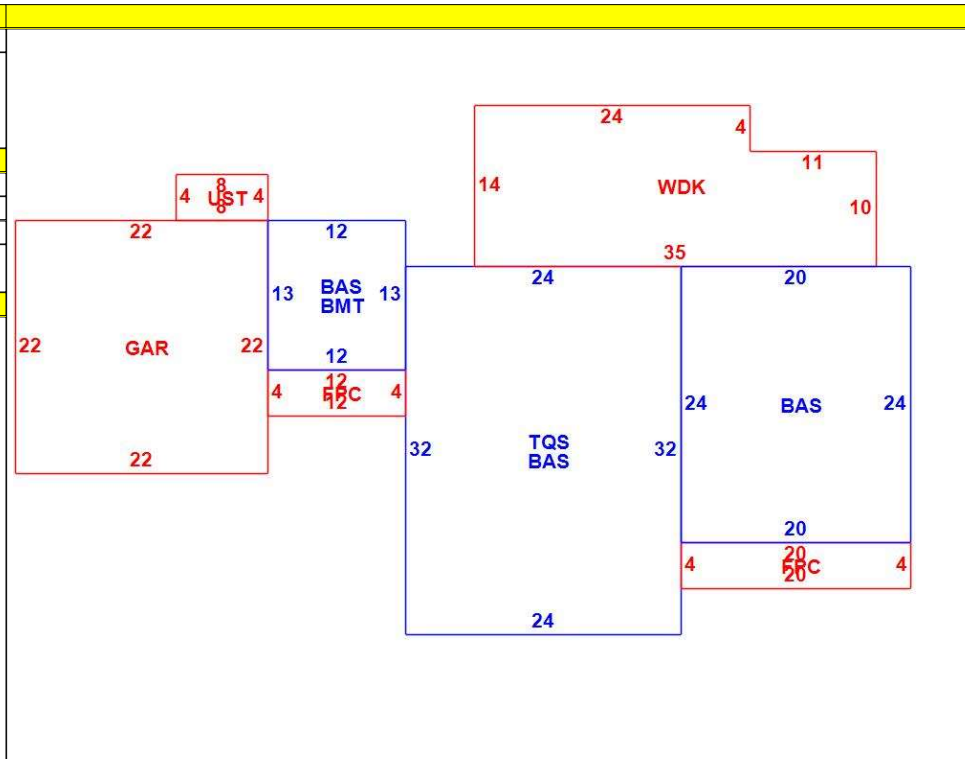

| OB - OUTBUILDING & YARD ITEMS(L) / XF - BUILDING EXTRA FEATURES(B) | | | | | | | | | | |
|--|------------------|-----|-------|------------|--------|----------|------|-------|------------|-------------|
| Code | Description | L/B | Units | Unit Price | Yr Blt | Cond. Cd | % Gd | Grade | Grade Adj. | Appr. Value |
| FPL1 | Fireplace 1 sto | B | 1 | 5000.00 | 2003 | | 86 | | 0.00 | 4,300 |
| WDC | Deck composi | L | 446 | 24.00 | 2021 | | 100 | | 0.00 | 10,200 |
| FOPC | Open Prch-roo | B | 128 | 55.00 | 2003 | | 86 | | 0.00 | 4,700 |
| GAR | Attached Gara | B | 484 | 40.00 | 2003 | | 86 | | 0.00 | 15,600 |
| UST | Utility Storage- | B | 32 | 17.11 | 2003 | | 86 | | 0.00 | 500 |
| BMT | Basement-Unfi | B | 156 | 26.01 | 2003 | | 86 | | 0.00 | 6,300 |

| BUILDING SUB-AREA SUMMARY SECTION | | | | | | |
|-----------------------------------|------------------------|-------------|------------|----------|-----------|----------------|
| Code | Description | Living Area | Floor Area | Eff Area | Unit Cost | Undeprec Value |
| BAS | First Floor | 1,404 | 1,404 | 1,404 | 279.21 | 392,015 |
| BMT | Basement Area | 0 | 156 | 0 | 0.00 | 0 |
| FPC | Open Porch Conc. Floor | 0 | 128 | 0 | 0.00 | 0 |
| GAR | Attached Garage | 0 | 484 | 0 | 0.00 | 0 |
| TQS | Three Quarter Story | 499 | 768 | 499 | 181.42 | 139,327 |
| UST | Utility Enclosure | 0 | 32 | 0 | 0.00 | 0 |
| WDK | Wood Deck | 0 | 446 | 0 | 0.00 | 0 |
| Ttl Gross Liv / Lease Area | | 1,903 | 3,418 | 1,903 | | 531,342 |

