

| CURRENT OWNER | | TOPO | UTILITIES | STRT / ROAD | LOCATION | CURRENT ASSESSMENT | | | |
|--|--|---------|--|-------------|----------|-----------------------|------|----------|----------|
| DOYLE, TIMOTHY C & KATHLEEN M PO BOX 1620 COTUIT MA 02635 | | 1 Level | 2 Public Water | 3 Unpaved | | Description | Code | Assessed | Assessed |
| | | | 4 Gas | | | RESIDNTL | 1010 | 282,100 | 282,100 |
| | | | 6 Septic | | | RES LAND | 1010 | 245,700 | 245,700 |
| SUPPLEMENTAL DATA | | | | | | | | | |
| Alt Prcl ID Split Zonin BID Parcel ResExpt Q YES: #DL 1 LOT 59 #DL 2 GIS ID F_942339_2683724 | | | Plan Ref. 19/143 Land Ct# #SR Life Estate PP STATU Assoc Pid# | | | Total 527,800 527,800 | | | |

801
 FY2024
 BARNSTABLE, MA

VISION

| RECORD OF OWNERSHIP | | BK-VOL/PAGE | SALE DATE | Q/U | V/I | SALE PRIC | VC | PREVIOUS ASSESSMENTS (HISTORY) | | | | | |
|-------------------------------|--|-------------|------------|-----|-----|-----------|----|--------------------------------|---------|----------|---------|-------|----------|
| DOYLE, TIMOTHY C & KATHLEEN M | | 6647 0094 | 03-15-1989 | Q | I | 142,400 | U | Year | Code | Assessed | Year | Code | Assessed |
| WISE, LEO J & JOSEPHINE A | | 6051 0181 | 12-15-1987 | Q | I | 133,000 | U | 2023 | 1010 | 220,700 | 2022 | 1010 | 206,300 |
| SEGERSTEN, MARIE E | | 3430 0002 | 02-15-1982 | U | | 0 | | | 1010 | 223,400 | | 1010 | 153,700 |
| | | | | | | | | | | | 2021 | 1010 | 168,800 |
| | | | | | | | | | | | | 1010 | 156,000 |
| | | | | | | | | | | | | 1010 | 2,000 |
| | | | | | | | | Total | 444,100 | Total | 360,000 | Total | 326,800 |

| EXEMPTIONS | | | OTHER ASSESSMENTS | | | | | |
|------------|------|-----------------------|-------------------|------|-------------|--------|--------|----------|
| Year | Code | Description | Amount | Code | Description | Number | Amount | Comm Int |
| 2021 | 5C | RESIDENTIAL EXEMPTION | 0.00 | | | | | |
| Total | | | 0.00 | | | | | |

This signature acknowledges a visit by a Data Collector or Assessor

| ASSESSING NEIGHBORHOOD | | | |
|------------------------|-----------|---|---------|
| Nbhd | Nbhd Name | B | Tracing |
| 0107 | | | COTUIT |

| APPRAISED VALUE SUMMARY | |
|-------------------------------|---------|
| Appraised Bldg. Value (Card) | 251,200 |
| Appraised Xf (B) Value (Bldg) | 21,600 |
| Appraised Ob (B) Value (Bldg) | 9,300 |
| Appraised Land Value (Bldg) | 245,700 |
| Special Land Value | 0 |
| Total Appraised Parcel Value | 527,800 |
| Valuation Method | C |
| Total Appraised Parcel Value | 527,800 |

| NOTES | | | | | | | |
|-------|--|--|--|--|--|--|--|
| | | | | | | | |

| BUILDING PERMIT RECORD | | | | | | | | VISIT / CHANGE HISTORY | | | | | | |
|------------------------|------------|------|-------------|--------|------------|--------|------------|---------------------------|------------|----|------|----|----|-------------------|
| Permit Id | Issue Date | Type | Description | Amount | Insp Date | % Comp | Date Comp | Comments | Date | Id | Type | Is | Cd | Purpost/Result |
| 19-2824 | 08-30-2019 | 822 | Insulation | 430 | 06-30-2020 | 100 | 06-30-2020 | Insulation/Weatherization | 08-13-2021 | CK | 01 | | 03 | Cycl Insp Comp |
| | | | | | | | | | 07-10-2020 | LH | 03 | | 22 | Change of Address |
| | | | | | | | | | 07-07-2020 | PK | 03 | | 16 | In Office Review |
| | | | | | | | | | 06-04-2020 | DM | | | FR | Field Review |
| | | | | | | | | | 08-23-2019 | CK | 22 | | 22 | Change of Address |
| | | | | | | | | | 04-03-2012 | RB | 03 | | 16 | In Office Review |
| | | | | | | | | | 05-05-2011 | RB | 03 | | 16 | In Office Review |

| LAND LINE VALUATION SECTION | | | | | | | | | | | | | | | | | |
|-----------------------------|----------|----------------|------|----|------------|------------|----------|---------|------------|-------|-------|-----------|-------|--------------------|------------|------------|---------|
| B | Use Code | Description | Zone | LA | Land Units | Unit Price | Size Adj | AC Disc | Site Index | Cond. | Nbhd. | Nbhd. Adj | Notes | Location Adjustmen | Adj Unit P | Land Value | |
| 1 | 1010 | Single Fam M-0 | RF | 2 | 0.950 AC | 176,344.00 | 1.04774 | 1.0000 | 5 | 1.00 | 0107 | 1.400 | | | 1.0000 | 258,661.3 | 245,700 |

| CONSTRUCTION DETAIL | | | CONSTRUCTION DETAIL (CONTINUED) | | |
|---------------------|-----|----------------|---------------------------------|----|-------------|
| Element | Cd | Description | Element | Cd | Description |
| Style | 07 | Modern/Contemp | | | |
| Model | 01 | Residential | | | |
| Grade: | C+ | Average Plus | | | |
| Stories | 1.5 | 1 1/2 Stories | | | |
| Exterior Wall 1 | 06 | Vertical Sidin | | | |
| Exterior Wall 2 | 14 | Wood Shingle | | | |
| RooF Structure | 03 | Gable/Hip | | | |
| RooF Cover | 03 | Asph/F Gls/Cmp | | | |
| Interior Wall 1 | 05 | Drywall | | | |
| Interior Wall 2 | | | | | |
| Interior Floor 1 | 12 | Hardwood | | | |
| Interior Floor 2 | | | | | |
| Heat Fuel | 03 | Gas | | | |
| Heat Type | 04 | Hot Air | | | |
| AC Type | 03 | Central | | | |
| Bedrooms | 03 | 3 Bedrooms | | | |
| Full Baths | 1 | | | | |
| Half Baths | 0 | | | | |
| Extra Fixtures | | | | | |
| Total Rooms | 5 | 5 Rooms | | | |
| Bath Style | | | | | |
| Kitchen Style | | | | | |
| Occupancy | | | | | |
| Usrflid 105 | | | | | |
| Accessory Apt | | | | | |
| Foundation Alt | 01 | Poured Conc. | | | |
| Rms Prts | | | | | |
| Bath Split | 10 | 1 Full-0 Half | | | |

| CONDO DATA | | | | |
|-------------|------|-------------|---------|----------|
| Parcel Id | | C | | Owne 0.0 |
| | | | B | S |
| Adjust Type | Code | Description | Factor% | |
| Condo Flr | | | | |
| Condo Unit | | | | |

| COST / MARKET VALUATION | | |
|--------------------------|--|---------|
| Building Value New | | 302,642 |
| Year Built | | 1972 |
| Effective Year Built | | 1997 |
| Depreciation Code | | G |
| Remodel Rating | | |
| Year Remodeled | | |
| Depreciation % | | 17 |
| Functional Obsol | | 0 |
| External Obsol | | 0 |
| Trend Factor | | 1 |
| Condition | | |
| Condition % | | |
| Percent Good | | 83 |
| RCNLD | | 251,200 |
| Dep % Ovr | | |
| Dep Ovr Comment | | |
| Misc Imp Ovr | | |
| Misc Imp Ovr Comment | | |
| Cost to Cure Ovr | | |
| Cost to Cure Ovr Comment | | |

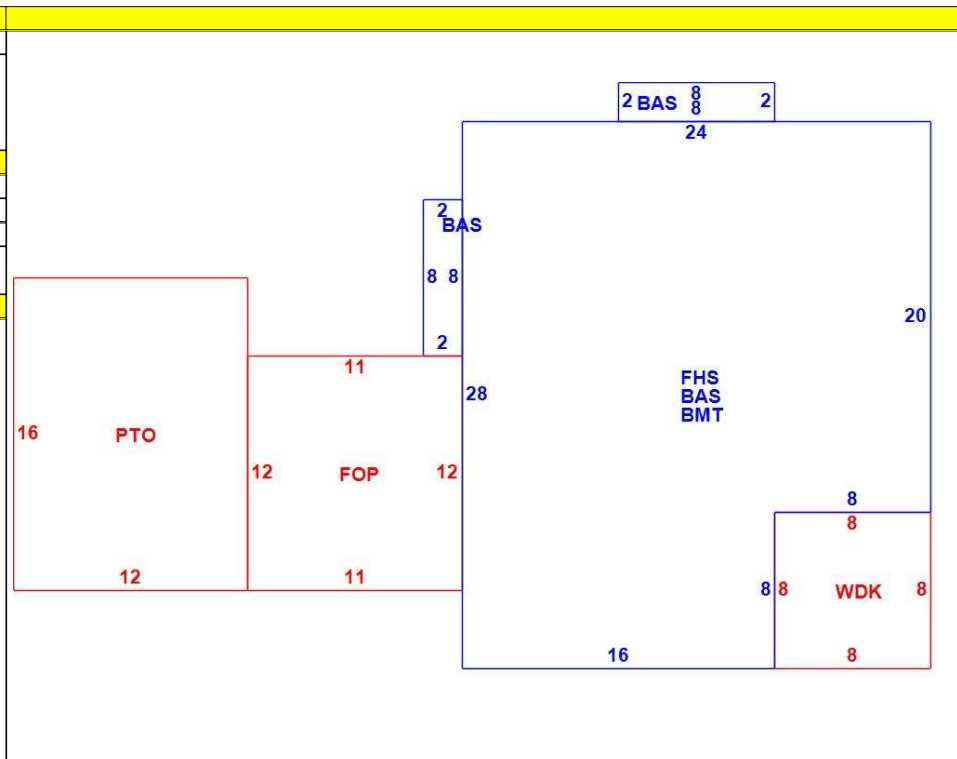

| OB - OUTBUILDING & YARD ITEMS(L) / XF - BUILDING EXTRA FEATURES(B) | | | | | | | | | | |
|--|---------------|-----|-------|------------|--------|----------|------|-------|------------|-------------|
| Code | Description | L/B | Units | Unit Price | Yr Blt | Cond. Cd | % Gd | Grade | Grade Adj. | Appr. Value |
| WDC | Wood Decking | L | 64 | 20.00 | 2000 | | 62 | | 0.00 | 2,000 |
| FOP | Open Porch-ro | B | 132 | 55.00 | 1999 | | 83 | | 0.00 | 5,600 |
| BMT | Basement-Unfi | B | 608 | 26.01 | 1999 | | 83 | | 0.00 | 16,000 |
| PATF | Flagstone Pav | L | 192 | 30.00 | 2020 | | 100 | | 0.00 | 6,400 |
| SHED | Shed | L | 96 | 18.00 | 1996 | | 54 | | 0.00 | 900 |

| BUILDING SUB-AREA SUMMARY SECTION | | | | | | |
|-----------------------------------|---------------|-------------|------------|----------|-----------|----------------|
| Code | Description | Living Area | Floor Area | Eff Area | Unit Cost | Undeprec Value |
| BAS | First Floor | 640 | 640 | 640 | 320.60 | 205,181 |
| BMT | Basement Area | 0 | 608 | 0 | 0.00 | 0 |
| FHS | Half Story | 304 | 608 | 304 | 160.30 | 97,461 |
| FOP | Open Porch | 0 | 132 | 0 | 0.00 | 0 |
| PTO | Patio | 0 | 192 | 0 | 0.00 | 0 |
| WDK | Wood Deck | 0 | 64 | 0 | 0.00 | 0 |
| Ttl Gross Liv / Lease Area | | 944 | 2,244 | 944 | | 302,642 |

