

| CONSTRUCTION DETAIL | | | CONSTRUCTION DETAIL (CONTINUED) | | |
|--------------------------|------|---------------|---------------------------------|-----|-------------|
| Element | Cd | Description | Element | Cd | Description |
| Style | 04 | Cape Cod | | | |
| Model | 01 | Residential | | | |
| Grade: | C+ | Average Plus | | | |
| Stories | 1.5 | 1 1/2 Stories | | | |
| Exterior Wall 1 | 14 | Wood Shingle | | | |
| Exterior Wall 2 | 11 | Clapboard | | | |
| Roof Structure | 03 | Gable/Hip | | | |
| Roof Cover | 10 | Wood Shingle | | | |
| Interior Wall 1 | 05 | Drywall | | | |
| Interior Wall 2 | | | | | |
| Interior Floor 1 | 12 | Hardwood | | | |
| Interior Floor 2 | | | | | |
| Heat Fuel | 03 | Gas | | | |
| Heat Type | 05 | Hot Water | | | |
| AC Type | 01 | None | | | |
| Bedrooms | 03 | 3 Bedrooms | | | |
| Full Baths | 2 | | | | |
| Half Baths | 1 | | | | |
| Extra Fixtures | | | | | |
| Total Rooms | 7 | 7 Rooms | | | |
| Bath Style | | | | | |
| Kitchen Style | | | | | |
| Occupancy | | | | | |
| Usrflid 105 | | | | | |
| Accessory Apt | | | | | |
| Foundation Alt | 01 | Poured Conc. | | | |
| Rms Prts | | | | | |
| Bath Split | 21 | 2 Full-1 Half | | | |
| CONDO DATA | | | COST / MARKET VALUATION | | |
| Parcel Id | | C | Owne | 0.0 | |
| Adjust Type | Code | Description | Factor% | | |
| Condo Flr | | | | | |
| Condo Unit | | | | | |
| Building Value New | | 496,040 | | | |
| Year Built | | 1978 | | | |
| Effective Year Built | | 1995 | | | |
| Depreciation Code | | A | | | |
| Remodel Rating | | | | | |
| Year Remodeled | | | | | |
| Depreciation % | | 19 | | | |
| Functional Obsol | | 0 | | | |
| External Obsol | | 0 | | | |
| Trend Factor | | 1 | | | |
| Condition | | | | | |
| Condition % | | | | | |
| Percent Good | | 81 | | | |
| RCNLD | | 401,800 | | | |
| Dep % Ovr | | | | | |
| Dep Ovr Comment | | | | | |
| Misc Imp Ovr | | | | | |
| Misc Imp Ovr Comment | | | | | |
| Cost to Cure Ovr | | | | | |
| Cost to Cure Ovr Comment | | | | | |

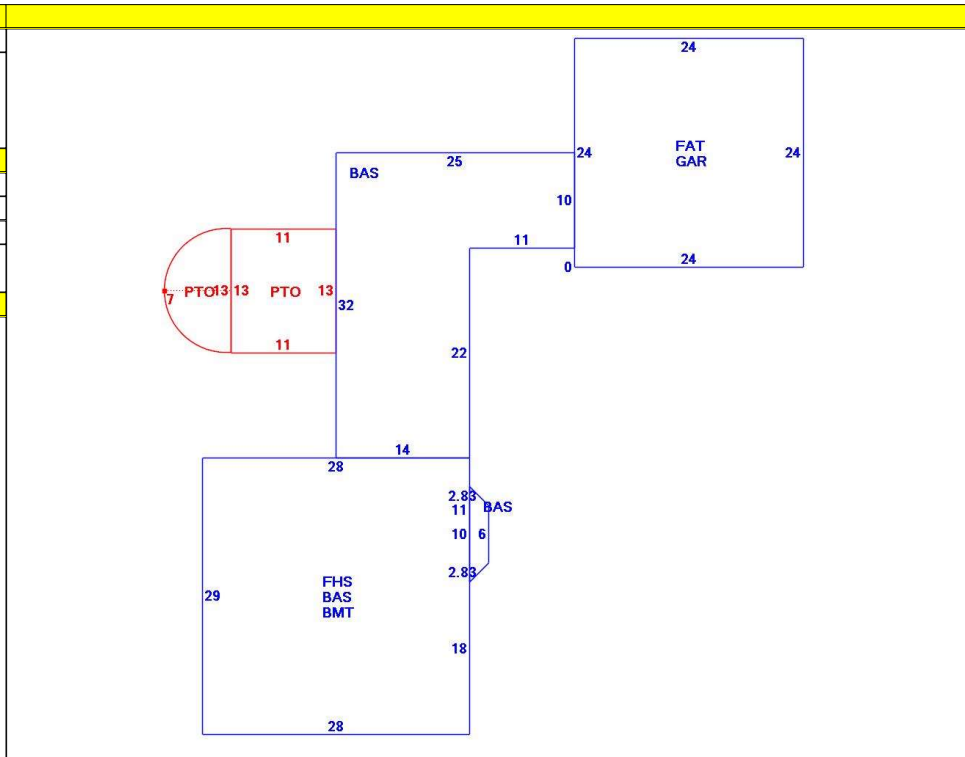

| OB - OUTBUILDING & YARD ITEMS(L) / XF - BUILDING EXTRA FEATURES(B) | | | | | | | | | | |
|--|-----------------|-----|-------|------------|--------|----------|------|-------|------------|-------------|
| Code | Description | L/B | Units | Unit Price | Yr Blt | Cond. Cd | % Gd | Grade | Grade Adj. | Appr. Value |
| FPL2 | Fireplace 1.5 s | B | 1 | 6000.00 | 1997 | | 81 | | 0.00 | 4,900 |
| PAT2 | Patio-Good | L | 216 | 9.94 | 1997 | | 78 | | 0.00 | 1,800 |
| GAR | Attached Gara | B | 576 | 40.00 | 1997 | | 81 | | 0.00 | 16,600 |
| BMT | Basement-Unfi | B | 812 | 26.01 | 1997 | | 81 | | 0.00 | 18,500 |

| BUILDING SUB-AREA SUMMARY SECTION | | | | | | |
|-----------------------------------|-----------------|-------------|------------|----------|-----------|----------------|
| Code | Description | Living Area | Floor Area | Eff Area | Unit Cost | Undeprec Value |
| BAS | First Floor | 1,386 | 1,386 | 1,386 | 264.13 | 366,087 |
| BMT | Basement Area | 0 | 812 | 0 | 0.00 | 0 |
| FAT | Attic, Finished | 86 | 576 | 86 | 39.44 | 22,715 |
| FHS | Half Story | 406 | 812 | 406 | 132.07 | 107,238 |
| GAR | Attached Garage | 0 | 576 | 0 | 0.00 | 0 |
| PTO | Patio | 0 | 216 | 0 | 0.00 | 0 |
| Ttl Gross Liv / Lease Area | | 1,878 | 4,378 | 1,878 | | 496,040 |

