

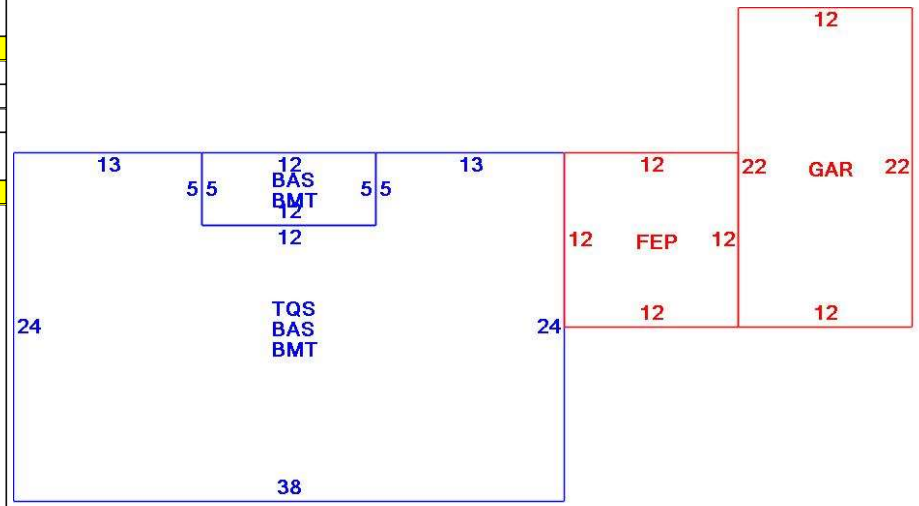

CONSTRUCTION DETAIL			CONSTRUCTION DETAIL (CONTINUED)		
Element	Cd	Description	Element	Cd	Description
Style	63	Gambrel			
Model	01	Residential			
Grade:	C	Average			
Stories	1.8				
Exterior Wall 1	14	Wood Shingle			
Exterior Wall 2	11	Clapboard			
Roof Structure	07	Gambrel			
Roof Cover	03	Asph/F Gls/Cmp			
Interior Wall 1	05	Drywall			
Interior Wall 2					
Interior Floor 1	14	Carpet			
Interior Floor 2					
Heat Fuel	03	Gas			
Heat Type	05	Hot Water			
AC Type	01	None			
Bedrooms	04	4 Bedrooms			
Full Baths	2				
Half Baths	0				
Extra Fixtures					
Total Rooms	7	7 Rooms			
Bath Style					
Kitchen Style					
Occupancy					
Usrflid 105					
Accessory Apt					
Foundation Alt	01	Poured Conc.			
Rms Prts					
Bath Split	20	2 Full-0 Half			

CONDO DATA			
Parcel Id		C	Ownr 0.0
		B	S
Adjust Type	Code	Description	Factor%
Condo Flr			
Condo Unit			

COST / MARKET VALUATION	
Building Value New	367,013
Year Built	1964
Effective Year Built	1988
Depreciation Code	A
Remodel Rating	
Year Remodeled	
Depreciation %	24
Functional Obsol	0
External Obsol	0
Trend Factor	1
Condition	
Condition %	
Percent Good	76
RCNLD	278,900
Dep % Ovr	
Dep Ovr Comment	
Misc Imp Ovr	
Misc Imp Ovr Comment	
Cost to Cure Ovr	
Cost to Cure Ovr Comment	



OB - OUTBUILDING & YARD ITEMS(L) / XF - BUILDING EXTRA FEATURES(B)										
Code	Description	L/B	Units	Unit Price	Yr Blt	Cond. Cd	% Gd	Grade	Grade Adj.	Appr. Value
FPL2	Fireplace 1.5 s	B	1	6000.00	1990		76		0.00	4,600
FEP	Enclosed porc	B	144	70.00	1990		76		0.00	7,800
GAR	Attached Gara	B	264	40.00	1990		76		0.00	9,300
BMT	Basement-Unfi	B	912	26.01	1990		76		0.00	18,900

BUILDING SUB-AREA SUMMARY SECTION						
Code	Description	Living Area	Floor Area	Eff Area	Unit Cost	Undeprec Value
BAS	First Floor	912	912	912	250.35	228,319
BMT	Basement Area	0	912	0	0.00	0
FEP	Enclosed Porch	0	144	0	0.00	0
GAR	Attached Garage	0	264	0	0.00	0
TQS	Three Quarter Story	554	852	554	162.79	138,694
Ttl Gross Liv / Lease Area		1,466	3,084	1,466		367,013

