

| CURRENT OWNER | | TOPO | UTILITIES | STRT / ROAD | LOCATION | CURRENT ASSESSMENT | | | | 801 FY2024 BARNSTABLE, MA VISION | |
|---|--|---------|----------------|--|----------|--------------------|------|----------|----------|--|---------|
| ST GEORGE, KERRY J TR ORCHARD KSG REALTY TRUST 5 ORCHARD STREET MEDWAY MA 02053 | | 1 Level | 2 Public Water | 1 Paved | | Description | Code | Assessed | Assessed | | |
| | | | 4 Gas | | | RESIDNTL | 1010 | 340,000 | 340,000 | | |
| | | | 6 Septic | | | RES LAND | 1010 | 152,900 | 152,900 | | |
| SUPPLEMENTAL DATA | | | | | | Total | | | | 492,900 | 492,900 |
| Alt Prcl ID Split Zonin BID Parcel ResExpt Q #DL 1 LOT 44 #DL 2 GIS ID F_969341_2703420 | | | | Plan Ref. Land Ct# 30545-A (SH 1) #SR Life Estate PP STATU Assoc Pid# | | | | | | | |

| RECORD OF OWNERSHIP | | BK-VOL/PAGE | SALE DATE | Q/U | V/I | SALE PRIC | VC | PREVIOUS ASSESSMENTS (HISTORY) | | | | | | | | |
|-----------------------------------|---------|-------------|------------|------|------------|-----------|------|--------------------------------|-------|---------|----------|-------|---------|---------|------|---------|
| Year | Code | Assessed | Year | Code | Assessed V | Year | Code | Assessed | Year | Code | Assessed | | | | | |
| ST GEORGE, KERRY J TR | C211407 | 0 | 11-25-2016 | U | I | 1 | 1F | 2023 | 1010 | 294,100 | 2022 | 1010 | 255,400 | 2021 | 1010 | 209,600 |
| QUINN, JOSEPH & ST GEORGE, KERRY | C208376 | 0 | 12-28-2015 | Q | I | 290,000 | 00 | | 1010 | 139,000 | | 1010 | 103,000 | | 1010 | 103,000 |
| WHITE, BARIT | C135975 | 0 | 12-15-1994 | U | I | 95,000 | F | | | | | | | | 1010 | 2,500 |
| WHITE, RICHARD P & PAUL K & CASH, | #D59224 | 0 | 09-15-1993 | U | I | 1 | F | | | | | | | | | |
| WHITE, KATHERINE L | C115014 | 0 | 08-15-1988 | U | I | 1 | A | | | | | | | | | |
| Total | | | | | | | | 433,100 | Total | | 358,400 | Total | | 315,100 | | |

| EXEMPTIONS | | | | OTHER ASSESSMENTS | | | | This signature acknowledges a visit by a Data Collector or Assessor | | | | |
|------------|------|-------------|--------|-------------------|-------------|--------|--------|---|--|--|--|--|
| Year | Code | Description | Amount | Code | Description | Number | Amount | Comm Int | | | | |
| | | | | | | | | | | | | |
| Total | | | 0.00 | | | | | | | | | |

| ASSESSING NEIGHBORHOOD | | | | APPRAISED VALUE SUMMARY | | | | |
|------------------------------|-----------|---|---------|-------------------------|-------------------------------|--|---------|---------|
| Nbhd | Nbhd Name | B | Tracing | Batch | | | | |
| 0105 | | | | CENVIL | Appraised Bldg. Value (Card) | | | 288,500 |
| | | | | | Appraised Xf (B) Value (Bldg) | | | 49,000 |
| | | | | | Appraised Ob (B) Value (Bldg) | | | 2,500 |
| | | | | | Appraised Land Value (Bldg) | | | 152,900 |
| | | | | | Special Land Value | | | 0 |
| | | | | | Total Appraised Parcel Value | | | 492,900 |
| | | | | | Valuation Method | | | C |
| Total Appraised Parcel Value | | | | | | | 492,900 | |

| BUILDING PERMIT RECORD | | | | | | | VISIT / CHANGE HISTORY | | | | | | | |
|------------------------|------------|------|-------------|--------|-----------|--------|------------------------|----------|------------|----|------|----|----|----------------------------|
| Permit Id | Issue Date | Type | Description | Amount | Insp Date | % Comp | Date Comp | Comments | Date | Id | Type | Is | Cd | Purpost/Result |
| | | | | | | | | | 04-28-2020 | LS | | | FR | Field Review |
| | | | | | | | | | 01-31-2020 | CK | 02 | | 03 | Cycl Insp Comp |
| | | | | | | | | | 06-02-2016 | JR | 03 | | 20 | Sale Review |
| | | | | | | | | | 03-31-2011 | RB | 03 | | 03 | Cycl Insp Comp |
| | | | | | | | | | 01-06-2009 | PT | 02 | | 14 | Cyclical Inspection |
| | | | | | | | | | 08-08-2001 | PT | 01 | | 00 | Meas/Listed-Interior Acces |

| LAND LINE VALUATION SECTION | | | | | | | | | | | | | | | | | |
|-----------------------------|----------|----------------|------|----|------------|------------|------------------------|---------|------------|-------|-------|-----------|------------------|--------------------|------------|------------|---------|
| B | Use Code | Description | Zone | LA | Land Units | Unit Price | Size Adj | AC Disc | Site Index | Cond. | Nbhd. | Nbhd. Adj | Notes | Location Adjustmen | Adj Unit P | Land Value | |
| 1 | 1010 | Single Fam M-0 | RC | 3 | 0.370 | AC | 176,344.00 | 2.34343 | 1.0000 | 5 | 1.00 | 0105 | 1.000 | | 1.0000 | 413,244.5 | 152,900 |
| Total Card Land Units | | | | | 0.37 | AC | Parcel Total Land Area | | | | | 0.37 | Total Land Value | | | 152,900 | |

| CONSTRUCTION DETAIL | | | CONSTRUCTION DETAIL (CONTINUED) | | |
|---------------------|----|----------------|---------------------------------|----|-------------|
| Element | Cd | Description | Element | Cd | Description |
| Style | 01 | Ranch | | | |
| Model | 01 | Residential | | | |
| Grade: | C | Average | | | |
| Stories | 1 | 1 Story | | | |
| Exterior Wall 1 | 14 | Wood Shingle | | | |
| Exterior Wall 2 | 20 | Brick/Masonry | | | |
| RooF Structure | 03 | Gable/Hip | | | |
| RooF Cover | 03 | Asph/F Gls/Cmp | | | |
| Interior Wall 1 | 05 | Drywall | | | |
| Interior Wall 2 | | | | | |
| Interior Floor 1 | 12 | Hardwood | | | |
| Interior Floor 2 | | | | | |
| Heat Fuel | 03 | Gas | | | |
| Heat Type | 04 | Hot Air | | | |
| AC Type | 03 | Central | | | |
| Bedrooms | 02 | 2 Bedrooms | | | |
| Full Baths | 1 | | | | |
| Half Baths | 1 | | | | |
| Extra Fixtures | | | | | |
| Total Rooms | 5 | 5 Rooms | | | |
| Bath Style | | | | | |
| Kitchen Style | | | | | |
| Occupancy | | | | | |
| Usrflid 105 | | | | | |
| Accessory Apt | | | | | |
| Foundation Alt | 01 | Poured Conc. | | | |
| Rms Prts | | | | | |
| Bath Split | 11 | 1 Full-1 Half | | | |

| CONDO DATA | | | | |
|-------------|------|-------------|---------|-----|
| Parcel Id | | C | Owne | 0.0 |
| Adjust Type | Code | Description | Factor% | |
| Condo Flr | | | | |
| Condo Unit | | | | |

| COST / MARKET VALUATION | | |
|--------------------------|--|---------|
| Building Value New | | 343,416 |
| Year Built | | 1964 |
| Effective Year Built | | 1998 |
| Depreciation Code | | VG |
| Remodel Rating | | |
| Year Remodeled | | |
| Depreciation % | | 16 |
| Functional Obsol | | 0 |
| External Obsol | | 0 |
| Trend Factor | | 1 |
| Condition | | |
| Condition % | | |
| Percent Good | | 84 |
| RCNLD | | 288,500 |
| Dep % Ovr | | |
| Dep Ovr Comment | | |
| Misc Imp Ovr | | |
| Misc Imp Ovr Comment | | |
| Cost to Cure Ovr | | |
| Cost to Cure Ovr Comment | | |

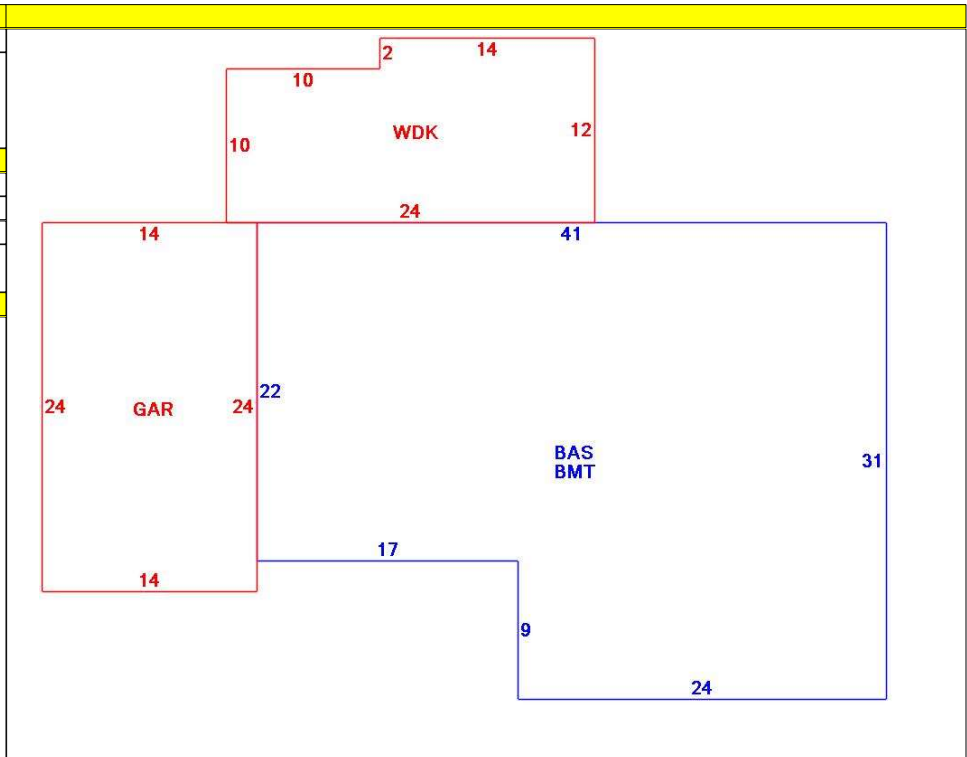

| OB - OUTBUILDING & YARD ITEMS(L) / XF - BUILDING EXTRA FEATURES(B) | | | | | | | | | | |
|--|-----------------|-----|-------|------------|--------|----------|------|-------|------------|-------------|
| Code | Description | L/B | Units | Unit Price | Yr Blt | Cond. Cd | % Gd | Grade | Grade Adj. | Appr. Value |
| FPL1 | Fireplace 1 sto | B | 1 | 5000.00 | 2000 | | 84 | | 0.00 | 4,200 |
| WDC | Wood Deck w/ | L | 268 | 18.00 | 1994 | | 50 | | 0.00 | 2,500 |
| GAR | Attached Gara | B | 336 | 40.00 | 2000 | | 84 | | 0.00 | 12,100 |
| BMT | Basement-Unfi | B | 1,118 | 26.01 | 2000 | | 84 | | 0.00 | 24,000 |
| BFA | Bsmt Fin-Avg | B | 600 | 17.36 | 2000 | | 84 | | 0.00 | 8,700 |

| BUILDING SUB-AREA SUMMARY SECTION | | | | | | |
|-----------------------------------|-----------------|-------------|------------|----------|-----------|----------------|
| Code | Description | Living Area | Floor Area | Eff Area | Unit Cost | Undeprec Value |
| BAS | First Floor | 1,118 | 1,118 | 1,118 | 307.17 | 343,416 |
| BMT | Basement Area | 0 | 1,118 | 0 | 0.00 | 0 |
| GAR | Attached Garage | 0 | 336 | 0 | 0.00 | 0 |
| WDK | Wood Deck | 0 | 268 | 0 | 0.00 | 0 |
| Ttl Gross Liv / Lease Area | | 1,118 | 2,840 | 1,118 | | 343,416 |

