

CURRENT OWNER		TOPO	UTILITIES	STRT / ROAD	LOCATION	CURRENT ASSESSMENT				801 FY2024 BARNSTABLE, MA  <b>VISION</b>
WHITE, BARBARA T TR BARBARA T WHITE 2008 TRUST 126 KNOTTY PINE LANE  CENTERVILLE MA 02632		1 Level	2 Public Water	1 Paved		Description	Code	Assessed	Assessed	
			4 Gas			RESIDNTL	1010	468,500	468,500	
			6 Septic			RES LAND	1010	165,800	165,800	
<b>SUPPLEMENTAL DATA</b>										
		Alt Prcl ID Split Zonin BID Parcel ResExpt Q YES: #DL 1 LOT 26 #DL 2 GIS ID F_969549_2705427			Plan Ref. Land Ct# 32898-B (SH 2) #SR Life Estate PP STATU Assoc Pid#		Total		634,300	634,300

RECORD OF OWNERSHIP		BK-VOL/PAGE	SALE DATE	Q/U	V/I	SALE PRIC	VC	PREVIOUS ASSESSMENTS (HISTORY)									
WHITE, BARBARA T TR		C205383	0	01-09-2015	U	I	1	1F	Year	Code	Assessed	Year	Code	Assessed	Year	Code	Assessed
WHITE, JAMES & BARBARA T		C175807	0	02-02-2005	U	I	1	1A	2023	1010	416,500	2022	1010	368,100	2021	1010	256,200
WHITE, RICHARD S & BARBARA T		C52472	0	09-20-1971	U		0			1010	150,700		1010	111,600		1010	111,600
																1010	57,700
									Total		567,200	Total		479,700	Total		425,500

EXEMPTIONS				OTHER ASSESSMENTS				This signature acknowledges a visit by a Data Collector or Assessor										
Year	Code	Description	Amount	Code	Description	Number	Amount	Comm Int										
2016	5C	RESIDENTIAL EXEMPTION	0.00															
			Total				0.00											

ASSESSING NEIGHBORHOOD				APPRAISED VALUE SUMMARY					
Nbhd	Nbhd Name		B	Tracing		Batch		Appraised Bldg. Value (Card)	355,900
0105						CENVIL		Appraised Xf (B) Value (Bldg)	54,900
								Appraised Ob (B) Value (Bldg)	57,700
								Appraised Land Value (Bldg)	165,800
								Special Land Value	0
								Total Appraised Parcel Value	634,300
								Valuation Method	C
								Total Appraised Parcel Value	634,300

NOTES										VISIT / CHANGE HISTORY					
										Date	Id	Type	Is	Cd	Purpost/Result
										01-19-2023	TR	03		16	In Office Review
										04-21-2020	LS			FR	Field Review
										02-03-2020	CK	01		03	Cycl Insp Comp
										10-22-2015	LH	03		16	In Office Review
										10-26-2006	NF	02		01	Meas/Est

LAND LINE VALUATION SECTION																
B	Use Code	Description	Zone	LA	Land Units	Unit Price	Size Adj	AC Disc	Site Index	Cond.	Nbhd.	Nbhd. Adj	Notes	Location Adjustmen	Adj Unit P	Land Value
1	1010	Single Fam M-0	RC	3	0.610 AC	176,344.00	1.54133	1.0000	5	1.00	0105	1.000		1.0000	271,799.0	165,800
Total Card Land Units					0.61	AC	Parcel Total Land Area					0.61	Total Land Value			165,800

CONSTRUCTION DETAIL			CONSTRUCTION DETAIL (CONTINUED)		
Element	Cd	Description	Element	Cd	Description
Style	01	Ranch			
Model	01	Residential			
Grade:	C	Average			
Stories	1	1 Story			
Exterior Wall 1	14	Wood Shingle			
Exterior Wall 2	25	Vinyl Siding			
Roof Structure	03	Gable/Hip			
Roof Cover	03	Asph/F Gls/Cmp			
Interior Wall 1	05	Drywall			
Interior Wall 2					
Interior Floor 1	12	Hardwood			
Interior Floor 2					
Heat Fuel	03	Gas			
Heat Type	05	Hot Water			
AC Type	03	Central			
Bedrooms	03	3 Bedrooms			
Full Baths	2				
Half Baths	0				
Extra Fixtures					
Total Rooms	6	6 Rooms			
Bath Style					
Kitchen Style					
Occupancy					
Usrflid 105					
Accessory Apt					
Foundation Alt	01	Poured Conc.			
Rms Prts					
Bath Split	20	2 Full-0 Half			
			<b>CONDO DATA</b>		
Parcel Id		C	Owne		0.0
Adjust Type		Code	Description		Factor%
Condo Flr		Condo Unit			
			<b>COST / MARKET VALUATION</b>		
Building Value New		456,334			
Year Built		1971			
Effective Year Built		1991			
Depreciation Code		A			
Remodel Rating					
Year Remodeled					
Depreciation %		22			
Functional Obsol		0			
External Obsol		0			
Trend Factor		1			
Condition					
Condition %					
Percent Good		78			
RCNLD		355,900			
Dep % Ovr					
Dep Ovr Comment					
Misc Imp Ovr					
Misc Imp Ovr Comment					
Cost to Cure Ovr					
Cost to Cure Ovr Comment					

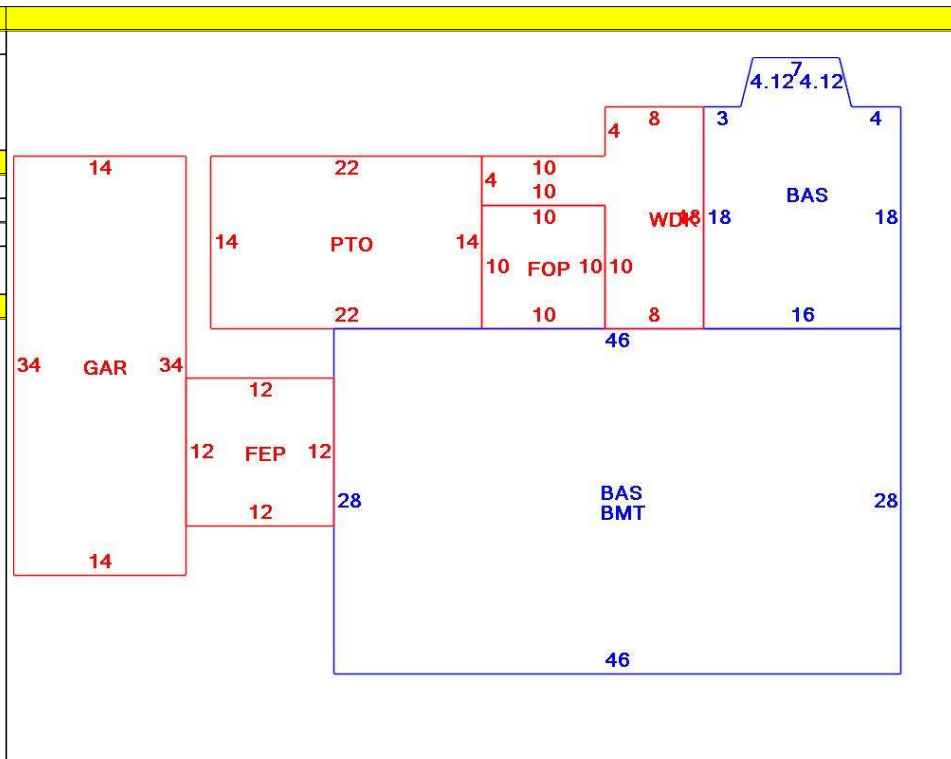

OB - OUTBUILDING & YARD ITEMS(L) / XF - BUILDING EXTRA FEATURES(B)										
Code	Description	L/B	Units	Unit Price	Yr Blt	Cond. Cd	% Gd	Grade	Grade Adj.	Appr. Value
FPL1	Fireplace 1 sto	B	1	5000.00	1993		78		0.00	3,900
FGR7	Gar w/Lft Goo	L	676	70.00	2006		87	00	1.00	41,200
WDC	Wood Decking	L	184	20.00	1996		54		0.00	2,500
PAT1	Patio- Average	L	308	5.89	1996		77		0.00	1,400
FOP	Open Porch-ro	B	100	55.00	1993		78		0.00	4,300
FEP	Enclosed porc	B	144	70.00	1993		78		0.00	8,000
GAR	Attached Gara	B	476	40.00	1993		78		0.00	14,000
BMT	Basement-Unfi	B	1,288	26.01	1993		78		0.00	24,700
GAZ1	Gazebo - Stan	L	1	12887.00	1996		54	C	1.00	7,000
GEN	Emergency Ge	L	1	5550.00	2019		100		0.00	5,600

BUILDING SUB-AREA SUMMARY SECTION						
Code	Description	Living Area	Floor Area	Eff Area	Unit Cost	Undeprec Value
BAS	First Floor	1,608	1,608	1,608	283.79	456,334
BMT	Basement Area	0	1,288	0	0.00	0
FEP	Enclosed Porch	0	144	0	0.00	0
FOP	Open Porch	0	100	0	0.00	0
GAR	Attached Garage	0	476	0	0.00	0
PTO	Patio	0	308	0	0.00	0
WDK	Wood Deck	0	184	0	0.00	0
Ttl Gross Liv / Lease Area		1,608	4,108	1,608		456,334



CURRENT OWNER		TOPO	UTILITIES	STRT / ROAD	LOCATION	CURRENT ASSESSMENT				801 FY2024 BARNSTABLE, MA  <b>VISION</b>	
WHITE, BARBARA T TR BARBARA T WHITE 2008 TRUST 126 KNOTTY PINE LANE  CENTERVILLE MA 02632		1 Level	2 Public Water	1 Paved		Description	Code	Assessed	Assessed		
			4 Gas			RESIDNTL	1010	468,500	468,500		
			6 Septic			RES LAND	1010	165,800	165,800		
<b>SUPPLEMENTAL DATA</b>						Total				634,300	634,300
		Alt Prcl ID	Split Zonin	Plan Ref.	Land Ct# 32898-B (SH 2)						
		BID Parcel	ResExpt Q YES:	Life Estate	PP STATU						
		#DL 1 LOT 26	#DL 2	Assoc Pid#							
		GIS ID F_969549_2705427									

RECORD OF OWNERSHIP		BK-VOL/PAGE	SALE DATE	Q/U	V/I	SALE PRIC	VC	PREVIOUS ASSESSMENTS (HISTORY)					
Year	Code	Assessed	Year	Code	Assessed V	Year	Code	Assessed	Year	Code	Assessed		
2023	1010	416,500	2022	1010	368,100	2021	1010	256,200					
	1010	150,700		1010	111,600		1010	111,600		1010	57,700		
Total		567,200	Total		479,700	Total		425,500					

EXEMPTIONS			OTHER ASSESSMENTS					This signature acknowledges a visit by a Data Collector or Assessor					
Year	Code	Description	Amount	Code	Description	Number	Amount	Comm Int					
Total													

ASSESSING NEIGHBORHOOD						APPRAISED VALUE SUMMARY					
Nbhd	Nbhd Name	B	Tracing	Batch		Appraised Bldg. Value (Card)	355,900				
0105			CENVIL			Appraised Xf (B) Value (Bldg)	54,900				
						Appraised Ob (B) Value (Bldg)	57,700				
						Appraised Land Value (Bldg)	165,800				
						Special Land Value	0				
						Total Appraised Parcel Value	634,300				
						Valuation Method	C				
						Total Appraised Parcel Value	634,300				

NOTES											

BUILDING PERMIT RECORD										VISIT / CHANGE HISTORY					
Permit Id	Issue Date	Type	Description	Amount	Insp Date	% Comp	Date Comp	Comments	Date	Id	Type	Is	Cd	Purpost/Result	

LAND LINE VALUATION SECTION																
B	Use Code	Description	Zone	LA	Land Units	Unit Price	Size Adj	AC Disc	Site Index	Cond.	Nbhd.	Nbhd. Adj	Notes	Location Adjustmen	Adj Unit P	Land Value
Total Card Land Units					Parcel Total Land Area					Total Land Value						

CONSTRUCTION DETAIL						CONSTRUCTION DETAIL (CONTINUED)					
Element	Cd	Description				Element	Cd	Description			
Style	01	Ranch									
Model	01	Residential									
Grade:	C	Average									
Stories	1	1 Story									
Exterior Wall 1	14	Wood Shingle				<b>CONDO DATA</b>					
Exterior Wall 2	25	Vinyl Siding				Parcel Id		C		Ownr	0.0
Roof Structure	03	Gable/Hip						B		S	
Roof Cover	03	Asph/F Gls/Cmp				Adjust Type	Code	Description	Factor%		
Interior Wall 1	05	Drywall				Condo Flr					
Interior Wall 2						Condo Unit					
Interior Floor 1	12	Hardwood				<b>COST / MARKET VALUATION</b>					
Interior Floor 2						Building Value New					
Heat Fuel	03	Gas				Year Built					
Heat Type	05	Hot Water				Effective Year Built					
AC Type	03	Central				Depreciation Code					
Bedrooms	03	3 Bedrooms				Remodel Rating					
Full Baths	2					Year Remodeled					
Half Baths	0					Depreciation %					
Extra Fixtures						Functional Obsol					
Total Rooms	6	6 Rooms				External Obsol					
Bath Style						Trend Factor					
Kitchen Style						Condition					
Occupancy						Condition %					
Usrflid 105						Percent Good					
Accessory Apt						RCNLD					
Foundation Alt	01	Poured Conc.				Dep % Ovr					
Rms Prts						Dep Ovr Comment					
Bath Split	20	2 Full-0 Half				Misc Imp Ovr					
						Misc Imp Ovr Comment					
						Cost to Cure Ovr					
						Cost to Cure Ovr Comment					
<b>OB - OUTBUILDING &amp; YARD ITEMS(L) / XF - BUILDING EXTRA FEATURES(B)</b>											
Code	Description	L/B	Units	Unit Price	Yr Blt	Cond. Cd	% Gd	Grade	Grade Adj.	Appr. Value	
SOL1	Solar PV Pane	B	16	860.00	2022		0		0.00	0	
<b>BUILDING SUB-AREA SUMMARY SECTION</b>											
Code	Description	Living Area	Floor Area	Eff Area	Unit Cost	Undeprec Value					
Ttl Gross Liv / Lease Area											