

| CURRENT OWNER | | TOPO | UTILITIES | STRT / ROAD | LOCATION | CURRENT ASSESSMENT | | | |
|---|--|---------|-------------------|-------------|----------|-----------------------|------|----------|----------|
| CELLI, CHRISTOPHER & NICOLAS, K 27 WINDLASS LANE CENTERVILLE MA 02632 | | 1 Level | 2 Public Water | 1 Paved | | Description | Code | Assessed | Assessed |
| | | | 4 Gas | | | RESIDNTL | 1010 | 452,300 | 452,300 |
| | | | 6 Septic | | | RES LAND | 1010 | 152,600 | 152,600 |
| SUPPLEMENTAL DATA | | | | | | | | | |
| Alt Prcl ID | | | Plan Ref. 236/127 | | | | | | |
| Split Zonin | | | Land Ct# | | | | | | |
| BID Parcel | | | #SR | | | | | | |
| ResExpt Q | | | Life Estate | | | | | | |
| #DL 1 LOT 5 | | | PP STATU | | | | | | |
| #DL 2 | | | Assoc Pid# | | | | | | |
| GIS ID F_968117_2707360 | | | | | | Total 604,900 604,900 | | | |

801
FY2024
BARNSTABLE, MA

VISION

| RECORD OF OWNERSHIP | | BK-VOL/PAGE | SALE DATE | Q/U | V/I | SALE PRIC | VC | PREVIOUS ASSESSMENTS (HISTORY) | | | | | |
|-----------------------------------|--|-------------|------------|-----|-----|-----------|----|--------------------------------|------|----------|-------|------|----------|
| CELLI, CHRISTOPHER & NICOLAS, KAT | | 33557 0286 | 12-09-2020 | Q | I | 405,000 | 00 | Year | Code | Assessed | Year | Code | Assessed |
| CONNOLLY, PATRICIA & MCCARTHY, MA | | 23706 0106 | 05-15-2009 | U | I | 10,000 | 1A | 2023 | 1010 | 387,600 | 2022 | 1010 | 332,900 |
| MCCARTHY, MARY C ET AL | | 20941 0120 | 04-26-2006 | Q | I | 350,000 | 00 | | 1010 | 138,700 | | 1010 | 102,700 |
| NICKERSON, ROBERT A & LAURA TRS | | 14448 0020 | 11-15-2001 | Q | I | 285,000 | 00 | | | | | 1010 | 4,200 |
| OLIVA, NICHOLAS F & MELANIE M | | 7918 0072 | 03-15-1992 | U | I | 1 | 1A | Total | | 526,300 | Total | | 435,600 |
| | | | | | | | | Total | | | Total | | 374,100 |

| EXEMPTIONS | | | OTHER ASSESSMENTS | | | | | |
|------------|------|-------------|-------------------|------|-------------|--------|--------|----------|
| Year | Code | Description | Amount | Code | Description | Number | Amount | Comm Int |
| | | | | | | | | |
| Total | | | 0.00 | | | | | |

This signature acknowledges a visit by a Data Collector or Assessor

| ASSESSING NEIGHBORHOOD | | | |
|------------------------|-----------|---|---------|
| Nbhd | Nbhd Name | B | Tracing |
| 0105 | | | CENVIL |

| APPRAISED VALUE SUMMARY | |
|-------------------------------|---------|
| Appraised Bldg. Value (Card) | 406,900 |
| Appraised Xf (B) Value (Bldg) | 41,200 |
| Appraised Ob (B) Value (Bldg) | 4,200 |
| Appraised Land Value (Bldg) | 152,600 |
| Special Land Value | 0 |
| Total Appraised Parcel Value | 604,900 |
| Valuation Method | C |
| Total Appraised Parcel Value | 604,900 |

| BUILDING PERMIT RECORD | | | | | | | | VISIT / CHANGE HISTORY | | | | | | |
|------------------------|------------|------|----------------|--------|------------|--------|-----------|-------------------------------|------------|----|------|----|----|----------------------------|
| Permit Id | Issue Date | Type | Description | Amount | Insp Date | % Comp | Date Comp | Comments | Date | Id | Type | Is | Cd | Purpost/Result |
| EXPR-22-9 | 07-05-2022 | 835 | Sid/Wind/Roof/ | 10,000 | | 100 | | strip and re-roof dwelling | 04-17-2020 | LS | | | FR | Field Review |
| EXPR-21-6 | 04-08-2021 | 835 | Sid/Wind/Roof/ | 5,179 | | 100 | | Insulation and Weatherization | 03-21-2018 | KM | 01 | | 03 | Cycl Insp Comp |
| B35062 | 05-01-1992 | WD | Wood Deck | 1,500 | 01-15-1993 | 100 | | CE DECK | 04-04-2011 | RB | 03 | | 03 | Cycl Insp Comp |
| | | | | | | | | | 06-29-2010 | TP | 03 | | 16 | In Office Review |
| | | | | | | | | | 02-04-2009 | PT | 02 | | 14 | Cyclical Inspection |
| | | | | | | | | | 08-08-2006 | JK | 22 | | 22 | Change of Address |
| | | | | | | | | | 01-27-2000 | PT | 01 | | 00 | Meas/Listed-Interior Acces |

| LAND LINE VALUATION SECTION | | | | | | | | | | | | | | | | | |
|-----------------------------|----------|----------------|------|----|------------|------------------------|----------|---------|------------|-------|-------|------------------|-------|--------------------|------------|------------|---------|
| B | Use Code | Description | Zone | LA | Land Units | Unit Price | Size Adj | AC Disc | Site Index | Cond. | Nbhd. | Nbhd. Adj | Notes | Location Adjustmen | Adj Unit P | Land Value | |
| 1 | 1010 | Single Fam M-0 | RC | 3 | 0.360 AC | 176,344.00 | 2.40337 | 1.0000 | 5 | 1.00 | 0105 | 1.000 | | 1.0000 | 423,825.1 | 152,600 | |
| Total Card Land Units | | | | | 0.36 AC | Parcel Total Land Area | | | | | 0.36 | Total Land Value | | | | | 152,600 |

| CONSTRUCTION DETAIL | | | CONSTRUCTION DETAIL (CONTINUED) | | |
|---------------------|----|----------------|---------------------------------|----|-------------|
| Element | Cd | Description | Element | Cd | Description |
| Style | 01 | Ranch | | | |
| Model | 01 | Residential | | | |
| Grade: | C | Average | | | |
| Stories | 1 | 1 Story | | | |
| Exterior Wall 1 | 14 | Wood Shingle | | | |
| Exterior Wall 2 | 25 | Vinyl Siding | | | |
| Roof Structure | 03 | Gable/Hip | | | |
| Roof Cover | 03 | Asph/F Gls/Cmp | | | |
| Interior Wall 1 | 05 | Drywall | | | |
| Interior Wall 2 | | | | | |
| Interior Floor 1 | 14 | Carpet | | | |
| Interior Floor 2 | | | | | |
| Heat Fuel | 03 | Gas | | | |
| Heat Type | 05 | Hot Water | | | |
| AC Type | 03 | Central | | | |
| Bedrooms | 03 | 3 Bedrooms | | | |
| Full Baths | 2 | | | | |
| Half Baths | 0 | | | | |
| Extra Fixtures | | | | | |
| Total Rooms | 7 | 7 Rooms | | | |
| Bath Style | | | | | |
| Kitchen Style | | | | | |
| Occupancy | | | | | |
| Usrflid 105 | | | | | |
| Accessory Apt | | | | | |
| Foundation Alt | 08 | Mixed | | | |
| Rms Prts | | | | | |
| Bath Split | 20 | 2 Full-0 Half | | | |

| CONDO DATA | | | |
|-------------|------------|-------------|---------|
| Parcel Id | C | Ownr | 0.0 |
| Adjust Type | Code | Description | Factor% |
| Condo Flr | Condo Unit | | |
| | | | |
| | | | |
| | | | |

| COST / MARKET VALUATION | |
|--------------------------|---------|
| Building Value New | 502,329 |
| Year Built | 1977 |
| Effective Year Built | 1994 |
| Depreciation Code | A |
| Remodel Rating | |
| Year Remodeled | |
| Depreciation % | 19 |
| Functional Obsol | 0 |
| External Obsol | 0 |
| Trend Factor | 1 |
| Condition | |
| Condition % | |
| Percent Good | 81 |
| RCNLD | 406,900 |
| Dep % Ovr | |
| Dep Ovr Comment | |
| Misc Imp Ovr | |
| Misc Imp Ovr Comment | |
| Cost to Cure Ovr | |
| Cost to Cure Ovr Comment | |

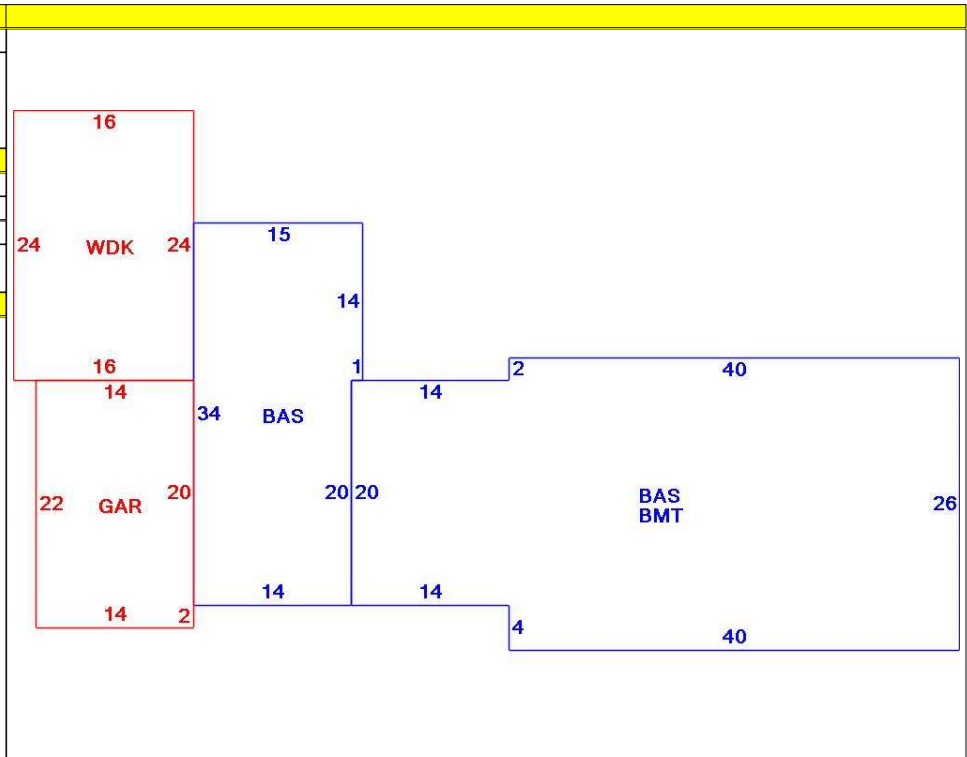

| OB - OUTBUILDING & YARD ITEMS(L) / XF - BUILDING EXTRA FEATURES(B) | | | | | | | | | | |
|--|-----------------|-----|-------|------------|--------|----------|------|-------|------------|-------------|
| Code | Description | L/B | Units | Unit Price | Yr Blt | Cond. Cd | % Gd | Grade | Grade Adj. | Appr. Value |
| FPL1 | Fireplace 1 sto | B | 1 | 5000.00 | 1996 | | 81 | | 0.00 | 4,100 |
| WDC | Wood Decking | L | 384 | 20.00 | 1997 | | 56 | | 0.00 | 4,200 |
| GAR | Attached Gara | B | 308 | 40.00 | 1996 | | 81 | | 0.00 | 11,000 |
| BMT | Basement-Unfi | B | 1,320 | 26.01 | 1996 | | 81 | | 0.00 | 26,100 |

| BUILDING SUB-AREA SUMMARY SECTION | | | | | | |
|-----------------------------------|-----------------|-------------|------------|----------|-----------|----------------|
| Code | Description | Living Area | Floor Area | Eff Area | Unit Cost | Undeprec Value |
| BAS | First Floor | 1,810 | 1,810 | 1,810 | 277.53 | 502,329 |
| BMT | Basement Area | 0 | 1,320 | 0 | 0.00 | 0 |
| GAR | Attached Garage | 0 | 308 | 0 | 0.00 | 0 |
| WDC | Wood Deck | 0 | 384 | 0 | 0.00 | 0 |
| Ttl Gross Liv / Lease Area | | 1,810 | 3,822 | 1,810 | | 502,329 |

