

CURRENT OWNER		TOPO	UTILITIES	STRT / ROAD	LOCATION	CURRENT ASSESSMENT				801 FY2024 BARNSTABLE, MA VISION
LISTER, WILMA A 10 MOORING DRIVE COTUIT MA 02635	1	Level	2	Public Water		Description RESIDNTL RES LAND	Code 1010 1010	Assessed 315,000 160,400	Assessed 315,000 160,400	
	4	Gas	1	Paved						
	6	Septic								
SUPPLEMENTAL DATA						Total				475,400
Alt Prcl ID Split Zonin BID Parcel ResExpt Q YES: #DL 1 LOT 81 #DL 2 GIS ID F_944771_2694797				Plan Ref. TUBE 167 Land Ct# #SR Life Estate PP STATU Assoc Pid#						475,400

RECORD OF OWNERSHIP		BK-VOL/PAGE	SALE DATE	Q/U	V/I	SALE PRIC	VC	PREVIOUS ASSESSMENTS (HISTORY)								
LISTER, TEDD & KRISTEN LISTER, WILMA A LISTER, WILMA A LISTER, ROBERT W & WILMA A HURLEY, EDITH A	35721	68	03-20-2023	U	I	0	1F	Year	Code	Assessed	Year	Code	Assessed	Year	Code	Assessed
	34908	128	02-15-2022	U	I	350,000	1A	2023	1010	272,300	2022	1010	239,000	2021	1010	195,400
	32519	0145	12-05-2019	U	I	1	1F		1010	145,800		1010	108,000		1010	108,000
	21851	0253	03-15-2007	Q	I	284,000	00								1010	2,700
4008	0346	02-15-1984	U	I	0	G	Total		418,100	Total		347,000	Total		306,100	

EXEMPTIONS				OTHER ASSESSMENTS				This signature acknowledges a visit by a Data Collector or Assessor								
Year	Code	Description	Amount	Code	Description	Number	Amount	Comm Int								
2023	5C	RESIDENTIAL EXEMPTION	0.00													
Total			0.00													

ASSESSING NEIGHBORHOOD				APPRAISED VALUE SUMMARY			
Nbhd	Nbhd Name	B	Tracing	Batch			
0105			COTUIT				

NOTES										APPRAISED VALUE SUMMARY	
										Appraised Bldg. Value (Card)	268,400
										Appraised Xf (B) Value (Bldg)	43,900
										Appraised Ob (B) Value (Bldg)	2,700
										Appraised Land Value (Bldg)	160,400
										Special Land Value	0
										Total Appraised Parcel Value	475,400
										Valuation Method	C
										Total Appraised Parcel Value	475,400

BUILDING PERMIT RECORD									VISIT / CHANGE HISTORY					
Permit Id	Issue Date	Type	Description	Amount	Insp Date	% Comp	Date Comp	Comments	Date	Id	Type	Is	Cd	Purpost/Result
B22406	08-01-1980	DW	Dwelling	0	01-15-1981	100	12-31-1981	CO 1 STOR	10-21-2022	JO			16	In Office Review
									05-14-2021	JD	03		16	In Office Review
									04-14-2021	JD	03		16	In Office Review
									03-03-2021	JD	03		16	In Office Review
									02-01-2021	JD	03		16	In Office Review
									05-28-2020	DM			FR	Field Review
									09-18-2013	RB	03		03	Cycl Insp Comp

LAND LINE VALUATION SECTION																	
B	Use Code	Description	Zone	LA	Land Units	Unit Price	Size Adj	AC Disc	Site Index	Cond.	Nbhd.	Nbhd. Adj	Notes	Location Adjustmen	Adj Unit P	Land Value	
1	1010	Single Fam M-0	RF	2	0.540	AC	176,344.00	1.68474	1.0000	5	1.00	0105	1.000		1.0000	297,086.7	160,400
Total Card Land Units					0.54	AC	Parcel Total Land Area					0.54	Total Land Value			160,400	

CONSTRUCTION DETAIL			CONSTRUCTION DETAIL (CONTINUED)		
Element	Cd	Description	Element	Cd	Description
Style	01	Ranch			
Model	01	Residential			
Grade:	C	Average			
Stories	1	1 Story			
Exterior Wall 1	14	Wood Shingle			
Exterior Wall 2					
RooF Structure	03	Gable/Hip			
RooF Cover	03	Asph/F Gls/Cmp			
Interior Wall 1	05	Drywall			
Interior Wall 2					
Interior Floor 1	14	Carpet			
Interior Floor 2					
Heat Fuel	03	Gas			
Heat Type	05	Hot Water			
AC Type	01	None			
Bedrooms	02	2 Bedrooms			
Full Baths	1				
Half Baths	1				
Extra Fixtures					
Total Rooms	5	5 Rooms			
Bath Style					
Kitchen Style					
Occupancy					
Usrflid 105					
Accessory Apt					
Foundation Alt	01	Poured Conc.			
Rms Prts					
Bath Split	11	1 Full-1 Half			

CONDO DATA			
Parcel Id		C	Owne 0.0
Adjust Type	Code	Description	Factor%
Condo Flr			
Condo Unit			

COST / MARKET VALUATION	
Building Value New	312,077
Year Built	1980
Effective Year Built	2001
Depreciation Code	G
Remodel Rating	
Year Remodeled	
Depreciation %	14
Functional Obsol	0
External Obsol	0
Trend Factor	1
Condition	
Condition %	
Percent Good	86
RCNLD	268,400
Dep % Ovr	
Dep Ovr Comment	
Misc Imp Ovr	
Misc Imp Ovr Comment	
Cost to Cure Ovr	
Cost to Cure Ovr Comment	

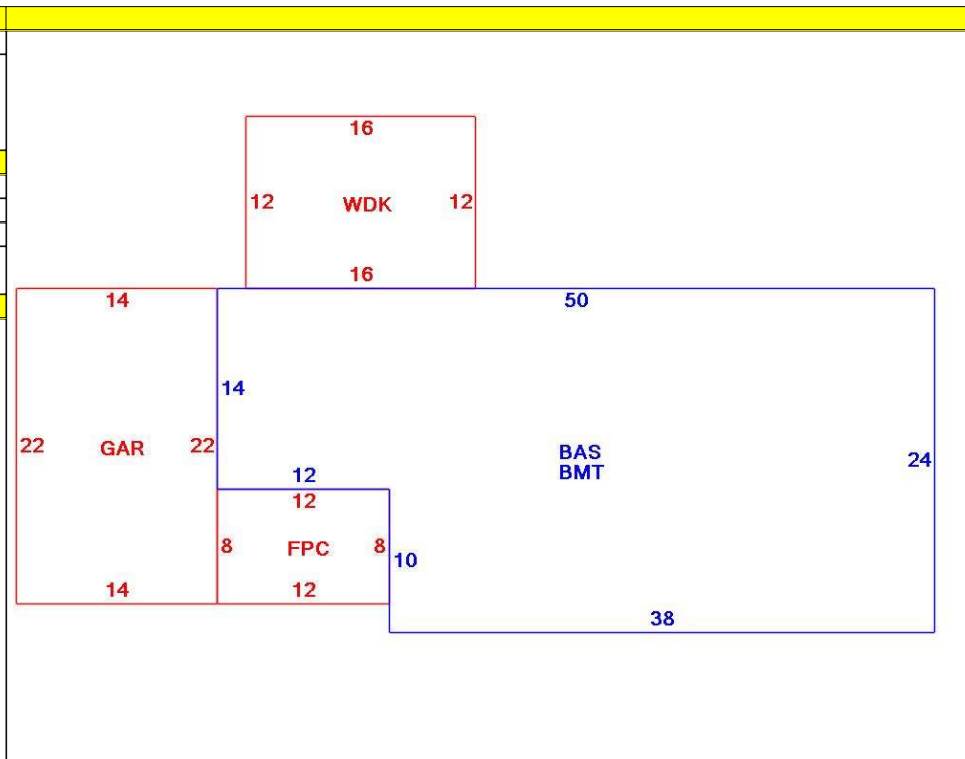

OB - OUTBUILDING & YARD ITEMS(L) / XF - BUILDING EXTRA FEATURES(B)										
Code	Description	L/B	Units	Unit Price	Yr Blt	Cond. Cd	% Gd	Grade	Grade Adj.	Appr. Value
FPL1	Fireplace 1 sto	B	1	5000.00	2003		86		0.00	4,300
WDC	Wood Decking	L	192	20.00	1998		58		0.00	2,700
FOPC	Open Prch-roo	B	96	55.00	2003		86		0.00	3,900
GAR	Attached Gara	B	308	40.00	2003		86		0.00	11,700
BMT	Basement-Unfi	B	1,080	26.01	2003		86		0.00	24,000

BUILDING SUB-AREA SUMMARY SECTION						
Code	Description	Living Area	Floor Area	Eff Area	Unit Cost	Undeprec Value
BAS	First Floor	1,080	1,080	1,080	288.96	312,077
BMT	Basement Area	0	1,080	0	0.00	0
FPC	Open Porch Conc. Floor	0	96	0	0.00	0
GAR	Attached Garage	0	308	0	0.00	0
WDK	Wood Deck	0	192	0	0.00	0
Ttl Gross Liv / Lease Area		1,080	2,756	1,080		312,077

