

| CURRENT OWNER   |  | TOPO                    | UTILITIES      | STRT / ROAD      | LOCATION | CURRENT ASSESSMENT |      |          |          | 801<br>FY2024<br>BARNSTABLE, MA<br><br><b>VISION</b> |         |
|---|--|-------------------------|----------------|------------------|----------|--------------------|------|----------|----------|--|---------|
| MICKUNAS, RUTA & EDMUND TRS<br>VISTA CIRCLE REALTY TRUST<br><br>12 VISTA CIRCLE<br>CENTERVILLE MA 02632 |  | 1 Level                 | 2 Public Water | 1 Paved          |          | Description        | Code | Assessed | Assessed |  |         |
|   |  |                         | 4 Gas          |                  |          | RESIDNTL           | 1010 | 441,900  | 441,900  |  |         |
|   |  |                         | 6 Septic       |                  |          | RES LAND           | 1010 | 151,900  | 151,900  |  |         |
| <b>SUPPLEMENTAL DATA</b>  |  |                         |                |                  |          | Total              |      |          |          | 593,800  | 593,800 |
|   |  | Alt Prcl ID             |                | Plan Ref. 386/27 |          |                    |      |          |          |  |         |
|   |  | Split Zonin             |                | Land Ct#         |          |                    |      |          |          |  |         |
|   |  | BID Parcel              |                | #SR              |          |                    |      |          |          |  |         |
|   |  | ResExpt Q YES:          |                | Life Estate      |          |                    |      |          |          |  |         |
|   |  | #DL 1 LOT 19            |                | PP STATU         |          |                    |      |          |          |  |         |
|   |  | #DL 2                   |                | Assoc Pid#       |          |                    |      |          |          |  |         |
|   |  | GIS ID F_969205_2710415 |                |                  |          |                    |      |          |          |  |         |

| RECORD OF OWNERSHIP               |       | BK-VOL/PAGE | SALE DATE  | Q/U | V/I | SALE PRIC | VC | PREVIOUS ASSESSMENTS (HISTORY) |      |          |       |      |          |       |      |          |
|-----------------------------------|-------|-------------|------------|-----|-----|-----------|----|--------------------------------|------|----------|-------|------|----------|-------|------|----------|
| MICKUNAS, RUTA & EDMUND TRS       | 36035 | 46          | 10-21-2011 | U   | I   | 0         | 1F | Year                           | Code | Assessed | Year  | Code | Assessed | Year  | Code | Assessed |
| JURKEVICIUS, KOSTAS & MICKUNAS, R | 13738 | 0218        | 04-18-2001 | U   | I   | 1         | 1A | 2023                           | 1010 | 381,600  | 2022  | 1010 | 334,400  | 2021  | 1010 | 269,200  |
| JURKEVICIUS, KOSTAS & JOSEPHINE   | 10326 | 0020        | 07-15-1996 | U   | I   | 165,900   | 1  |                                | 1010 | 138,100  |       | 1010 | 102,300  |       | 1010 | 102,300  |
| WILLIAMS, R ARTHUR & BETTY L      | 1400  | 0072        | 05-15-1968 | U   | V   | 0         |    | Total                          |      | 519,700  | Total |      | 436,700  | Total |      | 378,800  |

| EXEMPTIONS |      |                       |        | OTHER ASSESSMENTS |             |        |        | This signature acknowledges a visit by a Data Collector or Assessor |  |  |  |  |  |  |  |  |
|------------|------|-----------------------|--------|-------------------|-------------|--------|--------|---|--|--|--|--|--|--|--|--|
| Year       | Code | Description           | Amount | Code              | Description | Number | Amount | Comm Int  |  |  |  |  |  |  |  |  |
| 2020       | 5C   | RESIDENTIAL EXEMPTION | 0.00   |                   |             |        |        |   |  |  |  |  |  |  |  |  |
| Total      |      |                       | 0.00   |                   |             |        |        |   |  |  |  |  |  |  |  |  |

| ASSESSING NEIGHBORHOOD |           |   |         | APPRAISED VALUE SUMMARY |  |  |  |
|------------------------|-----------|---|---------|-------------------------|--|--|--|
| Nbhd                   | Nbhd Name | B | Tracing | Batch                   |  |  |  |
| 0105                   |           |   | CENVIL  |                         |  |  |  |

| NOTES |  |  |  |  |  |  |  |  |  |  |  | APPRAISED VALUE SUMMARY       |         |  |  |
|-------|--|--|--|--|--|--|--|--|--|--|--|-------------------------------|---------|--|--|
|       |  |  |  |  |  |  |  |  |  |  |  | Appraised Bldg. Value (Card)  | 379,200 |  |  |
|       |  |  |  |  |  |  |  |  |  |  |  | Appraised Xf (B) Value (Bldg) | 55,400  |  |  |
|       |  |  |  |  |  |  |  |  |  |  |  | Appraised Ob (B) Value (Bldg) | 7,300   |  |  |
|       |  |  |  |  |  |  |  |  |  |  |  | Appraised Land Value (Bldg)   | 151,900 |  |  |
|       |  |  |  |  |  |  |  |  |  |  |  | Special Land Value            | 0       |  |  |
|       |  |  |  |  |  |  |  |  |  |  |  | Total Appraised Parcel Value  | 593,800 |  |  |
|       |  |  |  |  |  |  |  |  |  |  |  | Valuation Method              | C       |  |  |
|       |  |  |  |  |  |  |  |  |  |  |  | Total Appraised Parcel Value  | 593,800 |  |  |

| BUILDING PERMIT RECORD |            |      |             |        |            |        |            |           | VISIT / CHANGE HISTORY |    |      |    |    |                            |
|------------------------|------------|------|-------------|--------|------------|--------|------------|-----------|------------------------|----|------|----|----|----------------------------|
| Permit Id              | Issue Date | Type | Description | Amount | Insp Date  | % Comp | Date Comp  | Comments  | Date                   | Id | Type | Is | Cd | Purpost/Result             |
| 10914                  | 10-01-1995 | DW   | Dwelling    | 80,000 | 01-15-1996 | 100    | 01-01-1997 | CE 1 STOR | 05-04-2020             | SR | 01   |    | 03 | Cycl Insp Comp             |
|                        |            |      |             |        |            |        |            |           | 04-17-2020             | LS |      |    | FR | Field Review               |
|                        |            |      |             |        |            |        |            |           | 08-12-2019             | TR | 03   |    | 16 | In Office Review           |
|                        |            |      |             |        |            |        |            |           | 07-20-2009             | PT | 02   |    | 14 | Cyclical Inspection        |
|                        |            |      |             |        |            |        |            |           | 11-21-2000             | PT | 01   |    | 00 | Meas/Listed-Interior Acces |

| LAND LINE VALUATION SECTION |          |                |      |    |            |            |                        |         |            |       |       |           |                  |                    |            |            |         |
|-----------------------------|----------|----------------|------|----|------------|------------|------------------------|---------|------------|-------|-------|-----------|------------------|--------------------|------------|------------|---------|
| B                           | Use Code | Description    | Zone | LA | Land Units | Unit Price | Size Adj               | AC Disc | Site Index | Cond. | Nbhd. | Nbhd. Adj | Notes            | Location Adjustmen | Adj Unit P | Land Value |         |
| 1                           | 1010     | Single Fam M-0 | RC   | 3  | 0.340      | AC         | 176,344.00             | 2.53383 | 1.0000     | 5     | 1.00  | 0105      | 1.000            |                    | 1.0000     | 446,820.4  | 151,900 |
| Total Card Land Units       |          |                |      |    | 0.34       | AC         | Parcel Total Land Area |         |            |       |       | 0.34      | Total Land Value |                    |            | 151,900    |         |

| CONSTRUCTION DETAIL |    |                | CONSTRUCTION DETAIL (CONTINUED) |    |             |
|---------------------|----|----------------|---------------------------------|----|-------------|
| Element             | Cd | Description    | Element                         | Cd | Description |
| Style               | 01 | Ranch          |                                 |    |             |
| Model               | 01 | Residential    |                                 |    |             |
| Grade:              | C  | Average        |                                 |    |             |
| Stories             | 1  | 1 Story        |                                 |    |             |
| Exterior Wall 1     | 25 | Vinyl Siding   |                                 |    |             |
| Exterior Wall 2     |    |                |                                 |    |             |
| Roof Structure      | 03 | Gable/Hip      |                                 |    |             |
| Roof Cover          | 03 | Asph/F Gls/Cmp |                                 |    |             |
| Interior Wall 1     | 03 | Plastered      |                                 |    |             |
| Interior Wall 2     |    |                |                                 |    |             |
| Interior Floor 1    | 11 | Ceram Clay Til |                                 |    |             |
| Interior Floor 2    | 23 | Laminate       |                                 |    |             |
| Heat Fuel           | 03 | Gas            |                                 |    |             |
| Heat Type           | 05 | Hot Water      |                                 |    |             |
| AC Type             | 03 | Central        |                                 |    |             |
| Bedrooms            | 03 | 3 Bedrooms     |                                 |    |             |
| Full Baths          | 2  |                |                                 |    |             |
| Half Baths          | 0  |                |                                 |    |             |
| Extra Fixtures      |    |                |                                 |    |             |
| Total Rooms         | 5  | 5 Rooms        |                                 |    |             |
| Bath Style          | 02 | Average        |                                 |    |             |
| Kitchen Style       | 02 | Modernized     |                                 |    |             |
| Occupancy           |    |                |                                 |    |             |
| Usrflid 105         |    |                |                                 |    |             |
| Accessory Apt       |    |                |                                 |    |             |
| Foundation Alt      | 01 | Poured Conc.   |                                 |    |             |
| Rms Prts            |    |                |                                 |    |             |
| Bath Split          | 20 | 2 Full-0 Half  |                                 |    |             |

| CONDO DATA  |      |             |         |     |
|-------------|------|-------------|---------|-----|
| Parcel Id   |      | C           | Owne    | 0.0 |
| Adjust Type | Code | Description | Factor% |     |
| Condo Flr   |      |             |         |     |
| Condo Unit  |      |             |         |     |

| COST / MARKET VALUATION  |         |         |
|--------------------------|---------|---------|
| Building Value New       |         | 430,885 |
| Year Built               |         | 1996    |
| Effective Year Built     |         | 2004    |
| Depreciation Code        |         | A       |
| Remodel Rating           |         |         |
| Year Remodeled           |         |         |
| Depreciation %           | 12      |         |
| Functional Obsol         | 0       |         |
| External Obsol           | 0       |         |
| Trend Factor             | 1       |         |
| Condition                |         |         |
| Condition %              |         |         |
| Percent Good             | 88      |         |
| RCNLD                    | 379,200 |         |
| Dep % Ovr                |         |         |
| Dep Ovr Comment          |         |         |
| Misc Imp Ovr             |         |         |
| Misc Imp Ovr Comment     |         |         |
| Cost to Cure Ovr         |         |         |
| Cost to Cure Ovr Comment |         |         |

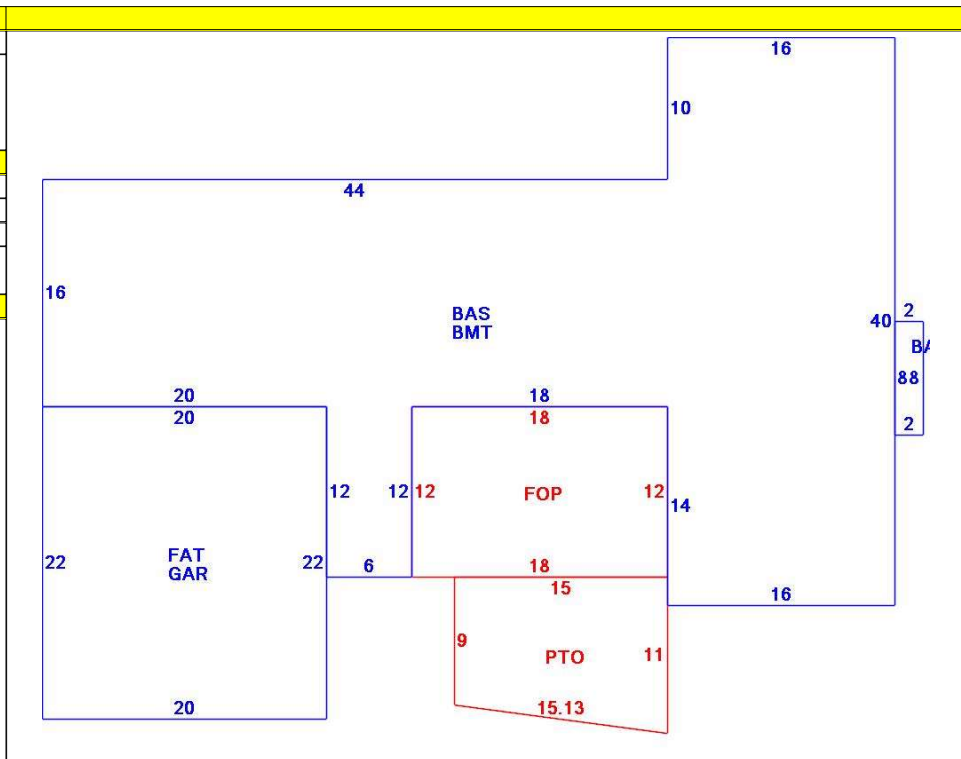

| OB - OUTBUILDING & YARD ITEMS(L) / XF - BUILDING EXTRA FEATURES(B) |                |     |       |            |        |          |      |       |            |             |
|--|----------------|-----|-------|------------|--------|----------|------|-------|------------|-------------|
| Code   | Description    | L/B | Units | Unit Price | Yr Blt | Cond. Cd | % Gd | Grade | Grade Adj. | Appr. Value |
| FPLG   | Gas Fireplace- | B   | 1     | 2500.00    | 2006   |          | 88   |       | 0.00       | 2,200       |
| FOP  | Open Porch-ro  | B   | 216   | 55.00      | 2006   |          | 88   |       | 0.00       | 8,300       |
| GAR  | Attached Gara  | B   | 440   | 40.00      | 2006   |          | 88   |       | 0.00       | 15,000      |
| BMT  | Basement-Unfi  | B   | 1,416 | 26.01      | 2006   |          | 88   |       | 0.00       | 29,900      |
| GEN  | Emergency Ge   | L   | 1     | 5550.00    | 2019   |          | 100  |       | 0.00       | 5,600       |
| PAT2   | Patio-Good     | L   | 150   | 9.94       | 2019   |          | 100  |       | 0.00       | 1,700       |

| BUILDING SUB-AREA SUMMARY SECTION |                 |             |            |          |           |                |
|-----------------------------------|-----------------|-------------|------------|----------|-----------|----------------|
| Code                              | Description     | Living Area | Floor Area | Eff Area | Unit Cost | Undeprec Value |
| BAS                               | First Floor     | 1,432       | 1,432      | 1,432    | 287.64    | 411,900        |
| BMT                               | Basement Area   | 0           | 1,416      | 0        | 0.00      | 0              |
| FAT                               | Attic, Finished | 66          | 440        | 66       | 43.15     | 18,984         |
| FOP                               | Open Porch      | 0           | 216        | 0        | 0.00      | 0              |
| GAR                               | Attached Garage | 0           | 440        | 0        | 0.00      | 0              |
| PTO                               | Patio           | 0           | 150        | 0        | 0.00      | 0              |
| Ttl Gross Liv / Lease Area        |                 | 1,498       | 4,094      | 1,498    |           | 430,884        |

