

CURRENT OWNER		TOPO	UTILITIES	STRT / ROAD	LOCATION	CURRENT ASSESSMENT				801 FY2024 BARNSTABLE, MA  <b>VISION</b>
DAVIES, CHERYL A & BROWN, BONN		1 Level	6 Septic	1 Paved		Description	Code	Assessed	Assessed	
PO BOX 584			5 Well			RESIDNTL	1010	281,400	281,400	
CAZENOVIA NY 13035		<b>SUPPLEMENTAL DATA</b>				RES LAND	1010	364,300	364,300	
Alt Prcl ID		Split Zonin		Plan Ref.						
BID Parcel		ResExpt Q		Land Ct#						
#DL 1		#DL 2		#SR						
GIS ID F_968446_2715782				Life Estate						
				PP STATU						
				Assoc Pid#						
						Total		645,700	645,700	

RECORD OF OWNERSHIP		BK-VOL/PAGE	SALE DATE	Q/U	V/I	SALE PRIC	VC	PREVIOUS ASSESSMENTS (HISTORY)						
DAVIES, CHERYL A & BROWN, BONNIE		34610	282	10-28-2021	U	I	1	1F	Year	Code	Assessed	Year	Code	Assessed
PRIEST, FAITH A		3928	0147	11-15-1983	Q	I	100,000	U	2023	1010	247,700	2022	1010	205,400
										1010	341,800		1010	263,400
												2021	1010	157,400
													1010	267,500
													1010	15,400
						Total		589,500	Total		468,800	Total		440,300

EXEMPTIONS			OTHER ASSESSMENTS				APPRaised VALUE SUMMARY					
Year	Code	Description	Amount	Code	Description	Number	Amount	Comm Int	This signature acknowledges a visit by a Data Collector or Assessor			
									Appraised Bldg. Value (Card) 266,000			
Total			0.00					Appraised Xf (B) Value (Bldg) 0				
<b>ASSESSING NEIGHBORHOOD</b>							Appraised Ob (B) Value (Bldg) 15,400					
Nbhd	Nbhd Name		B	Tracing		Batch		Appraised Land Value (Bldg) 364,300				
0107						WBARNS		Special Land Value 0				
<b>NOTES</b>							Total Appraised Parcel Value 645,700					
							Valuation Method C					
							Total Appraised Parcel Value 645,700					

BUILDING PERMIT RECORD								VISIT / CHANGE HISTORY						
Permit Id	Issue Date	Type	Description	Amount	Insp Date	% Comp	Date Comp	Comments	Date	Id	Type	Is	Cd	Purpost/Result
64393	10-09-2002	NR	New Roof	1,500	12-18-2002	100	01-01-2003		02-03-2022	BM	22		22	Change of Address
									05-18-2020	DM			FR	Field Review
									10-01-2019	SR	02		03	Cycl Insp Comp
									03-31-2014	JR	03		16	In Office Review
									12-18-2002	MF	02		02	Bldg Permit Completed
									09-20-2000	PT	01		00	Meas/Listed-Interior Acces

LAND LINE VALUATION SECTION																
B	Use Code	Description	Zone	LA	Land Units	Unit Price	Size Adj	AC Disc	Site Index	Cond.	Nbhd.	Nbhd. Adj	Notes	Location Adjustmen	Adj Unit P	Land Value
1	1010	Single Fam M-0	RF	5	1.000	AC 176,344.00	1.00000	1.0000	5	1.00	0107	1.400		1.0000	246,881.6	246,900
1	1010	Single Fam M-0	RF	5	6.260	AC 14,250.00	1.00000	0.9400	0	1.00	0107	1.400		1.0000	18,753	117,400
Total Card Land Units					7.26	AC	Parcel Total Land Area					7.26	Total Land Value			364,300

CONSTRUCTION DETAIL			CONSTRUCTION DETAIL (CONTINUED)		
Element	Cd	Description	Element	Cd	Description
Style	04	Cape Cod			
Model	01	Residential			
Grade:	C	Average			
Stories	1.5	1 1/2 Stories			
Exterior Wall 1	14	Wood Shingle			
Exterior Wall 2					
RooF Structure	03	Gable/Hip			
RooF Cover	03	Asph/F Gls/Cmp			
Interior Wall 1	03	Plastered			
Interior Wall 2					
Interior Floor 1	09	Pine/Soft Wood			
Interior Floor 2					
Heat Fuel	02	Oil			
Heat Type	04	Hot Air			
AC Type	03	Central			
Bedrooms	04	4 Bedrooms			
Full Baths	1				
Half Baths	0				
Extra Fixtures					
Total Rooms	6	6 Rooms			
Bath Style					
Kitchen Style					
Occupancy					
UsrflD 105					
Accessory Apt					
Foundation Alt	11	Stone Ftgs			
Rms Prts					
Bath Split	10	1 Full-0 Half			
			<b>CONDO DATA</b>		
			Parcel Id	C	Owne 0.0
			Adjust Type Code Description Factor%		
			Condo Flr		
			Condo Unit		
			<b>COST / MARKET VALUATION</b>		
			Building Value New		385,459
			Year Built		1700
			Effective Year Built		1979
			Depreciation Code		A
			Remodel Rating		
			Year Remodeled		
			Depreciation %		31
			Functional Obsol		0
			External Obsol		0
			Trend Factor		1
			Condition		
			Condition %		
			Percent Good		69
			RCNLD		266,000
			Dep % Ovr		
			Dep Ovr Comment		
			Misc Imp Ovr		
			Misc Imp Ovr Comment		
			Cost to Cure Ovr		
			Cost to Cure Ovr Comment		

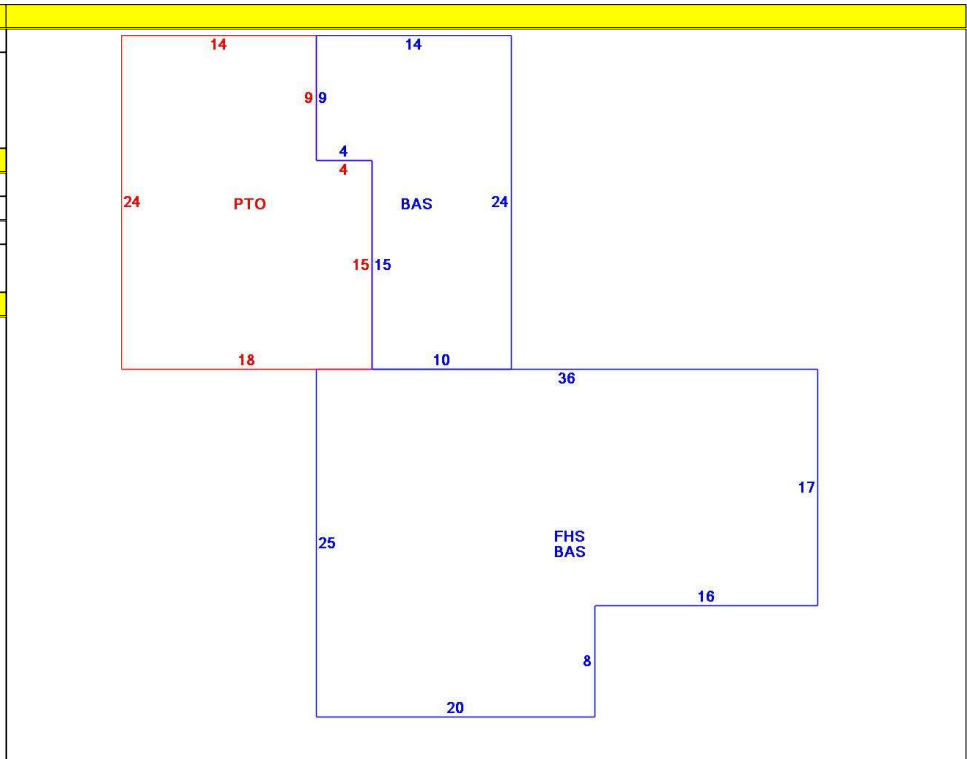

OB - OUTBUILDING & YARD ITEMS(L) / XF - BUILDING EXTRA FEATURES(B)										
Code	Description	L/B	Units	Unit Price	Yr Blt	Cond. Cd	% Gd	Grade	Grade Adj.	Appr. Value
BRN3	Barn w loft	L	480	39.66	1986		67	00	1.00	12,800
PAT2	Patio-Good	L	396	9.94	1986		67		0.00	2,600

BUILDING SUB-AREA SUMMARY SECTION						
Code	Description	Living Area	Floor Area	Eff Area	Unit Cost	Undeprec Value
BAS	First Floor	1,048	1,048	1,048	268.80	281,702
FHS	Half Story	386	772	386	134.40	103,757
PTO	Patio	0	396	0	0.00	0
Ttl Gross Liv / Lease Area		1,434	2,216	1,434		385,459

