

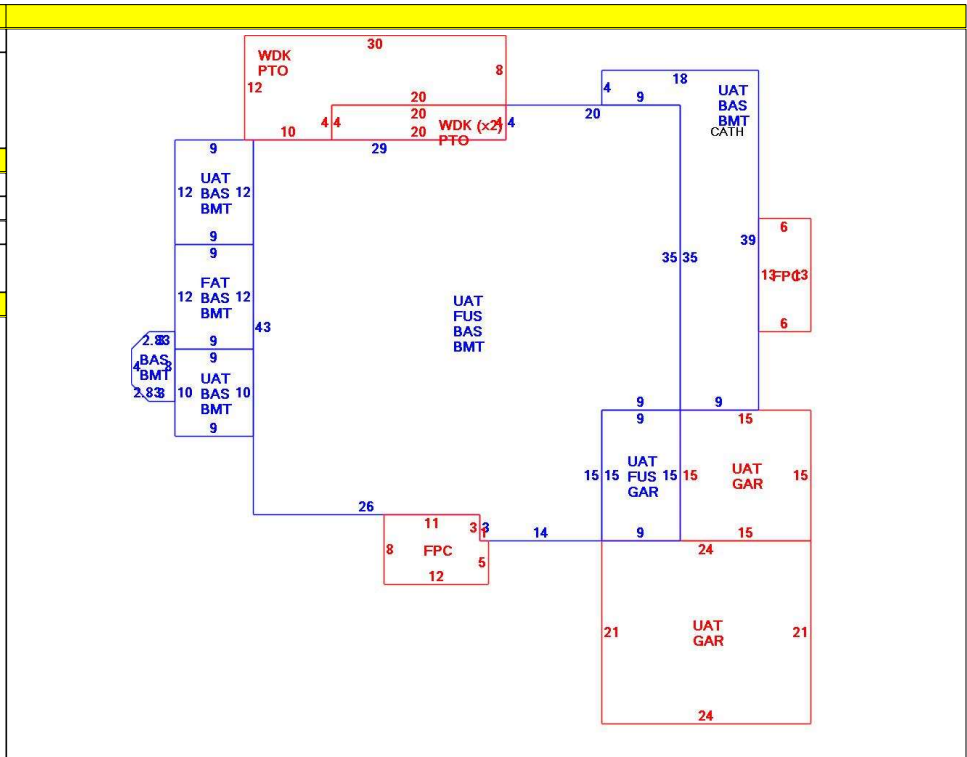

CONSTRUCTION DETAIL			CONSTRUCTION DETAIL (CONTINUED)		
Element	Cd	Description	Element	Cd	Description
Style	03	Colonial			
Model	01	Residential			
Grade:	B+	Custom Plus			
Stories	2.3				
Exterior Wall 1	11	Clapboard			
Exterior Wall 2					
RooF Structure	03	Gable/Hip			
RooF Cover	03	Asph/F Gls/Cmp			
Interior Wall 1	03	Plastered			
Interior Wall 2					
Interior Floor 1	12	Hardwood			
Interior Floor 2					
Heat Fuel	03	Gas			
Heat Type	05	Hot Water			
AC Type	03	Central			
Bedrooms	06	6 Bedrooms			
Full Baths	5				
Half Baths	0				
Extra Fixtures					
Total Rooms	10	10 Rooms			
Bath Style					
Kitchen Style					
Occupancy					
Usrflid 105					
Accessory Apt					
Foundation Alt	01	Poured Conc.			
Rms Prts					
Bath Split	50	5 Full-0 Half			
			<b>CONDO DATA</b>		
			Parcel Id	C	Owne 0.0
			Adjust Type Code Description Factor%		
			Condo Flr		
			Condo Unit		
			<b>COST / MARKET VALUATION</b>		
			Building Value New		1,506,760
			Year Built		2002
			Effective Year Built		2007
			Depreciation Code		A
			Remodel Rating		
			Year Remodeled		
			Depreciation %		9
			Functional Obsol		0
			External Obsol		0
			Trend Factor		1
			Condition		
			Condition %		
			Percent Good		91
			RCNLD		1,371,200
			Dep % Ovr		
			Dep Ovr Comment		
			Misc Imp Ovr		
			Misc Imp Ovr Comment		
			Cost to Cure Ovr		
			Cost to Cure Ovr Comment		



OB - OUTBUILDING & YARD ITEMS(L) / XF - BUILDING EXTRA FEATURES(B)										
Code	Description	L/B	Units	Unit Price	Yr Blt	Cond. Cd	% Gd	Grade	Grade Adj.	Appr. Value
FPL1	Fireplace 1 sto	B	3	5000.00	2009		91		0.00	13,700
WDC	Wood Decking	L	440	20.00	2006		74		0.00	6,200
PAT1	Patio- Average	L	360	5.89	2006		87		0.00	1,800
FOPC	Open Prch-roo	B	171	55.00	2009		91		0.00	6,100
GAR	Attached Gara	B	864	40.00	2009		91		0.00	25,100
BMT	Basement-Unfi	B	2,850	26.01	2009		91		0.00	54,500
DKPL	Pond Dock-Lig	L	1	4200.00	2003		100		0.00	4,200

BUILDING SUB-AREA SUMMARY SECTION						
Code	Description	Living Area	Floor Area	Eff Area	Unit Cost	Undeprec Value
BAS	First Floor	2,850	2,850	2,850	275.01	783,768
BMT	Basement Area	0	2,850	0	0.00	0
FAT	Attic, Finished	16	108	16	40.74	4,400
FPC	Open Porch Conc. Floor	0	171	0	0.00	0
FUS	Upper Story	2,256	2,256	2,256	275.01	620,414
GAR	Attached Garage	0	864	0	0.00	0
PTO	Patio	0	360	0	0.00	0
UAT	Attic, Unfinished	0	3,570	357	27.50	98,177
WDK	Wood Deck	0	440	0	0.00	0
Ttl Gross Liv / Lease Area		5,122	13,469	5,479		1,506,759

