

CURRENT OWNER		TOPO		UTILITIES		STRT / ROAD		LOCATION		CURRENT ASSESSMENT			
WHITTLESEY, LINDA B & MEGAN BO LINDA B WHITTLESEY REALTY TRUS 1560 MAIN ST./RTE 6A WEST BARNSTA MA 02668		1	Level	4	Gas	1	Paved	1	Water View	Description	Code	Assessed	Assessed
				5	Well					RESIDNTL	1010	435,900	435,900
				6	Septic					RES LAND	1010	275,400	275,400
SUPPLEMENTAL DATA													
		Alt Prcl ID Split Zonin BID Parcel ResExpt Q YES: #DL 1 PARCELA #DL 2 GIS ID F_968991_2717677				Plan Ref. 69/147 Land Ct# #SR Life Estate PP STATU Assoc Pid#				Total 711,300 711,300			

801
 FY2024
 BARNSTABLE, MA

VISION

RECORD OF OWNERSHIP		BK-VOL/PAGE		SALE DATE		Q/U		V/I		SALE PRIC		VC		PREVIOUS ASSESSMENTS (HISTORY)						
WHITTLESEY, LINDA B & MEGAN BONN WHITTLESEY, STEPHEN & LINDA B		23959	0347	08-12-2009		U	I			1	1A	Year	Code	Assessed	Year	Code	Assessed	Year	Code	Assessed
		1397	0013	04-11-1968		U				0		2023	1010	342,700	2022	1010	315,800	2021	1010	267,700
												Total 595,600		Total 496,700		Total 454,100				

EXEMPTIONS				OTHER ASSESSMENTS			
Year	Code	Description	Amount	Code	Description	Number	Amount
2010	5C	RESIDENTIAL EXEMPTION	0.00				
Total			0.00				

This signature acknowledges a visit by a Data Collector or Assessor

ASSESSING NEIGHBORHOOD			
Nbhd	Nbhd Name	B	Tracing
0107			WBARN

APPRAISED VALUE SUMMARY

Appraised Bldg. Value (Card)	398,800
Appraised Xf (B) Value (Bldg)	34,400
Appraised Ob (B) Value (Bldg)	2,700
Appraised Land Value (Bldg)	275,400
Special Land Value	0
Total Appraised Parcel Value	711,300
Valuation Method	C
Total Appraised Parcel Value	711,300

NOTES

BUILDING PERMIT RECORD								VISIT / CHANGE HISTORY							
Permit Id	Issue Date	Type	Description	Amount	Insp Date	% Comp	Date Comp	Comments	Date	Id	Type	Is	Cd	Purpost/Result	
EXPR-22-9	08-01-2022	835	Sid/Wind/Roof/	1,000		100		insulation and air sealing work	06-08-2020	SR	01		03	Cycl Insp Comp	
31209	05-27-1998	NR	New Roof	4,400	01-01-1999	100			05-18-2020	DM			FR	Field Review	
B31363	10-01-1987	AD	Addition	12,000	01-15-1988	100		WB 2ND FL	05-02-2014	AL	03		16	In Office Review	
									05-01-2000	PT	01		00	Meas/Listed-Interior Acces	
									03-15-1988	M					

LAND LINE VALUATION SECTION

B	Use Code	Description	Zone	LA	Land Units	Unit Price	Size Adj	AC Disc	Site Index	Cond.	Nbhd.	Nbhd. Adj	Notes	Location Adjustmen	Adj Unit P	Land Value	
1	1010	Single Fam M-0	RF	5	1.000	AC 176,344.00	1.00000	1.0000	5	1.00	0107	1.400		1.0000	246,881.6	246,900	
1	1010	Single Fam M-0	RF	5	1.410	AC 14,250.00	1.00000	1.0000	0	1.00	0107	1.400		1.0000	19,950	28,100	
1	1010	Single Fam M-0	RF	5	0.170	AC 2,375.00	1.00000	1.0000	0	1.00	WTLD	1.000	WETLAND	1.0000	2,375	400	
Total Card Land Units					2.58	AC	Parcel Total Land Area					2.58	Total Land Value				275,400

CONSTRUCTION DETAIL			CONSTRUCTION DETAIL (CONTINUED)		
Element	Cd	Description	Element	Cd	Description
Style	07	Modern/Contemp			
Model	01	Residential			
Grade:	C	Average			
Stories	2	2 Stories			
Exterior Wall 1	11	Clapboard			
Exterior Wall 2					
RooF Structure	03	Gable/Hip			
RooF Cover	03	Asph/F Gls/Cmp			
Interior Wall 1	05	Drywall			
Interior Wall 2					
Interior Floor 1	09	Pine/Soft Wood			
Interior Floor 2	14	Carpet			
Heat Fuel	03	Gas			
Heat Type	05	Hot Water			
AC Type	03	Central			
Bedrooms	04	4 Bedrooms			
Full Baths	2				
Half Baths	0				
Extra Fixtures					
Total Rooms	7	7 Rooms			
Bath Style					
Kitchen Style					
Occupancy					
UsrflD 105					
Accessory Apt					
Foundation Alt	00	Typical			
Rms Prts					
Bath Split	20	2 Full-0 Half			

CONDO DATA				
Parcel Id		C		Ownr 0.0
			B	S
Adjust Type	Code	Description	Factor%	
Condo Flr				
Condo Unit				

COST / MARKET VALUATION		
Building Value New		517,884
Year Built		1969
Effective Year Built		1990
Depreciation Code		A
Remodel Rating		
Year Remodeled		
Depreciation %		23
Functional Obsol		0
External Obsol		0
Trend Factor		1
Condition		
Condition %		
Percent Good		77
RCNLD		398,800
Dep % Ovr		
Dep Ovr Comment		
Misc Imp Ovr		
Misc Imp Ovr Comment		
Cost to Cure Ovr		
Cost to Cure Ovr Comment		

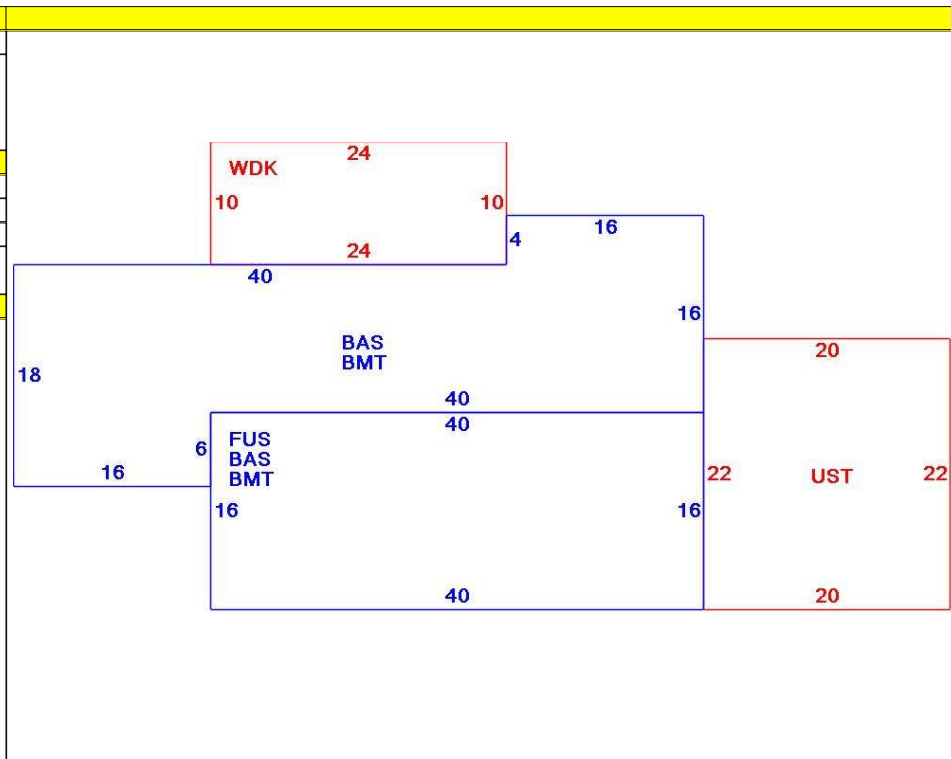

OB - OUTBUILDING & YARD ITEMS(L) / XF - BUILDING EXTRA FEATURES(B)										
Code	Description	L/B	Units	Unit Price	Yr Blt	Cond. Cd	% Gd	Grade	Grade Adj.	Appr. Value
WDC	Wood Decking	L	240	20.00	1995		52		0.00	2,700
UST	Utility Storage	B	440	17.11	1992		100		0.00	7,500
BMT	Basement-Unfi	B	1,472	26.01	1992		77		0.00	26,900

BUILDING SUB-AREA SUMMARY SECTION						
Code	Description	Living Area	Floor Area	Eff Area	Unit Cost	Undeprec Value
BAS	First Floor	1,472	1,472	1,472	245.21	360,949
BMT	Basement Area	0	1,472	0	0.00	0
FUS	Upper Story	640	640	640	245.21	156,934
UST	Utility Enclosure	0	440	0	0.00	0
WDK	Wood Deck	0	240	0	0.00	0
Ttl Gross Liv / Lease Area		2,112	4,264	2,112		517,883

