

| CURRENT OWNER                                       |  | TOPO   |        | UTILITIES |              | STRT / ROAD   |            | LOCATION |            | CURRENT ASSESSMENT  |                      |                                  |                                  |
|---|--|--|--------|-----------|--------------|---|------------|----------|------------|---|----------------------|----------------------------------|----------------------------------|
| PACKARD, DANIEL M<br>C/O GEMINI VALVE<br>2 OTTER CT |  | 1  | Level  | 2         | Public Water | 1   | Paved      | 7        | Waterfront | Description<br>RESIDNTL<br>RES LAND   | Code<br>1010<br>1010 | Assessed<br>549,100<br>1,894,900 | Assessed<br>549,100<br>1,894,900 |
|   |  | 4  | Gas    |           |              | 1   | Excel View |          |            |   |                      |                                  |                                  |
|   |  | 6  | Septic |           |              |   |            |          |            |   |                      |                                  |                                  |
| <b>SUPPLEMENTAL DATA</b>                            |  |  |        |           |              |   |            |          |            |   |                      |                                  |                                  |
| RAYMOND NH 03077                                    |  | Alt Prcl ID<br>Split Zonin<br>BID Parcel<br>ResExpt Q<br>#DL 1<br>#DL 2<br>GIS ID F_970534_2694792 |        |           |              | Plan Ref.<br>Land Ct#<br>#SR<br>Life Estate<br>PP STATU<br>Assoc Pid# |            |          |            | Total 2,444,000 2,444,000<br><div style="text-align: center; font-size: 2em; font-weight: bold;">VISION</div> |                      |                                  |                                  |
|   |  |  |        |           |              |   |            |          |            |   |                      |                                  |                                  |

| RECORD OF OWNERSHIP                 |  | BK-VOL/PAGE |      | SALE DATE  |  | Q/U |   | V/I     |  | SALE PRIC |      | VC        |         | PREVIOUS ASSESSMENTS (HISTORY) |           |         |          |           |         |          |      |         |          |
|-------------------------------------|--|-------------|------|------------|--|-----|---|---------|--|-----------|------|-----------|---------|--------------------------------|-----------|---------|----------|-----------|---------|----------|------|---------|----------|
| PACKARD, DANIEL M<br>GEHRING, CLARA |  | 4386        | 0015 | 01-15-1985 |  | Q   | I | 150,000 |  | U         |      |           |         |                                | Year      | Code    | Assessed | Year      | Code    | Assessed | Year | Code    | Assessed |
|                                     |  | 2613        | 0134 | 11-09-1977 |  | U   |   | 0       |  |           | 2023 | 1010      | 467,000 | 2022                           | 1010      | 391,500 | 2021     | 1010      | 969,800 | 2021     | 1010 | 309,600 |          |
|                                     |  |             |      |            |  |     |   |         |  | Total     |      | 2,189,700 | Total   |                                | 1,361,300 | Total   |          | 1,273,500 |         |          |      |         |          |

| EXEMPTIONS |      |             |        | OTHER ASSESSMENTS |             |        |        | This signature acknowledges a visit by a Data Collector or Assessor |  |  |  |  |  |  |  |  |  |  |  |
|------------|------|-------------|--------|-------------------|-------------|--------|--------|---|--|--|--|--|--|--|--|--|--|--|--|
| Year       | Code | Description | Amount | Code              | Description | Number | Amount |   |  |  |  |  |  |  |  |  |  |  |  |
|            |      |             | Total  | 0.00              |             |        |        |   |  |  |  |  |  |  |  |  |  |  |  |

| ASSESSING NEIGHBORHOOD |           |   |         | APPRaised VALUE SUMMARY       |           |  |  |
|------------------------|-----------|---|---------|-------------------------------|-----------|--|--|
| Nbhd                   | Nbhd Name | B | Tracing | Batch                         |           |  |  |
| 0118                   |           |   |         | CENVIL                        |           |  |  |
| NOTES                  |           |   |         | Appraised Bldg. Value (Card)  | 507,600   |  |  |
|                        |           |   |         | Appraised Xf (B) Value (Bldg) | 21,900    |  |  |
|                        |           |   |         | Appraised Ob (B) Value (Bldg) | 19,600    |  |  |
|                        |           |   |         | Appraised Land Value (Bldg)   | 1,894,900 |  |  |
|                        |           |   |         | Special Land Value            | 0         |  |  |
|                        |           |   |         | Total Appraised Parcel Value  | 2,444,000 |  |  |
|                        |           |   |         | Valuation Method              | C         |  |  |
|                        |           |   |         | Total Appraised Parcel Value  | 2,444,000 |  |  |

| BUILDING PERMIT RECORD |            |      |             |         |            |        |            |                         | VISIT / CHANGE HISTORY |    |      |    |    |                            |
|------------------------|------------|------|-------------|---------|------------|--------|------------|-------------------------|------------------------|----|------|----|----|----------------------------|
| Permit Id              | Issue Date | Type | Description | Amount  | Insp Date  | % Comp | Date Comp  | Comments                | Date                   | Id | Type | Is | Cd | Purpost/Result             |
| 201508261              | 12-23-2015 | AD   | Addition    | 120,000 | 06-14-2016 | 100    | 06-30-2018 | RAISE REAR WALL TO ALLO | 05-14-2020             | WD |      |    | FR | Field Review               |
| 67634                  | 03-24-2003 | AD   | Addition    | 52,000  | 06-04-2004 | 100    | 01-01-2004 |                         | 01-11-2017             | SR | 02   |    | 02 | Bldg Permit Completed      |
| B35559                 | 12-01-1992 | AD   | Addition    | 20,000  | 01-15-1994 | 100    | 12-31-1994 | CE FOUND.               | 08-20-2015             | JR | 03   |    | 20 | Sale Review                |
|                        |            |      |             |         |            |        |            |                         | 06-04-2004             | MF | 02   |    | 02 | Bldg Permit Completed      |
|                        |            |      |             |         |            |        |            |                         | 06-22-2001             | PT | 01   |    | 00 | Meas/Listed-Interior Acces |

| LAND LINE VALUATION SECTION |          |                |      |    |            |            |                        |         |            |       |       |           |                  |                    |            |            |           |           |
|-----------------------------|----------|----------------|------|----|------------|------------|------------------------|---------|------------|-------|-------|-----------|------------------|--------------------|------------|------------|-----------|-----------|
| B                           | Use Code | Description    | Zone | LA | Land Units | Unit Price | Size Adj               | AC Disc | Site Index | Cond. | Nbhd. | Nbhd. Adj | Notes            | Location Adjustmen | Adj Unit P | Land Value |           |           |
| 1                           | 1010     | Single Fam M-0 | CBD  | 3  | 0.330      | AC         | 176,344.00             | 2.60499 | 1.0000     | 5     | 1.00  | 0118      | 12.500           |                    | 1.0000     | 5,742,183  | 1,894,900 |           |
| Total Card Land Units       |          |                |      |    | 0.33       | AC         | Parcel Total Land Area |         |            |       |       | 0.33      | Total Land Value |                    |            |            |           | 1,894,900 |

| CONSTRUCTION DETAIL |    |                | CONSTRUCTION DETAIL (CONTINUED) |    |             |
|---------------------|----|----------------|---------------------------------|----|-------------|
| Element             | Cd | Description    | Element                         | Cd | Description |
| Style               | 06 | Conventional   |                                 |    |             |
| Model               | 01 | Residential    |                                 |    |             |
| Grade:              | C+ | Average Plus   |                                 |    |             |
| Stories             | 2  | 2 Stories      |                                 |    |             |
| Exterior Wall 1     | 14 | Wood Shingle   |                                 |    |             |
| Exterior Wall 2     |    |                |                                 |    |             |
| Roof Structure      | 03 | Gable/Hip      |                                 |    |             |
| Roof Cover          | 03 | Asph/F Gls/Cmp |                                 |    |             |
| Interior Wall 1     | 05 | Drywall        |                                 |    |             |
| Interior Wall 2     |    |                |                                 |    |             |
| Interior Floor 1    | 14 | Carpet         |                                 |    |             |
| Interior Floor 2    | 22 | Wide Pine      |                                 |    |             |
| Heat Fuel           | 03 | Gas            |                                 |    |             |
| Heat Type           | 05 | Hot Water      |                                 |    |             |
| AC Type             | 03 | Central        |                                 |    |             |
| Bedrooms            | 04 | 4 Bedrooms     |                                 |    |             |
| Full Baths          | 5  |                |                                 |    |             |
| Half Baths          | 0  |                |                                 |    |             |
| Extra Fixtures      |    |                |                                 |    |             |
| Total Rooms         | 7  | 7 Rooms        |                                 |    |             |
| Bath Style          |    |                |                                 |    |             |
| Kitchen Style       |    |                |                                 |    |             |
| Occupancy           |    |                |                                 |    |             |
| Usrflid 105         |    |                |                                 |    |             |
| Accessory Apt       |    |                |                                 |    |             |
| Foundation Alt      | 08 | Mixed          |                                 |    |             |
| Rms Prts            |    |                |                                 |    |             |
| Bath Split          | 50 | 5 Full-0 Half  |                                 |    |             |

| CONDO DATA |   |   |   |          |
|------------|---|---|---|----------|
| Parcel Id  | C | B | S | Ownr 0.0 |
|            |   |   |   |          |

| COST / MARKET VALUATION |      |             |         |  |
|-------------------------|------|-------------|---------|--|
| Adjust Type             | Code | Description | Factor% |  |
| Condo Flr               |      |             |         |  |
| Condo Unit              |      |             |         |  |

|                          |         |
|--------------------------|---------|
| Building Value New       | 659,210 |
| Year Built               | 1948    |
| Effective Year Built     | 1990    |
| Depreciation Code        | VG      |
| Remodel Rating           |         |
| Year Remodeled           |         |
| Depreciation %           | 23      |
| Functional Obsol         | 0       |
| External Obsol           | 0       |
| Trend Factor             | 1       |
| Condition                |         |
| Condition %              |         |
| Percent Good             | 77      |
| RCNLD                    | 507,600 |
| Dep % Ovr                |         |
| Dep Ovr Comment          |         |
| Misc Imp Ovr             |         |
| Misc Imp Ovr Comment     |         |
| Cost to Cure Ovr         |         |
| Cost to Cure Ovr Comment |         |

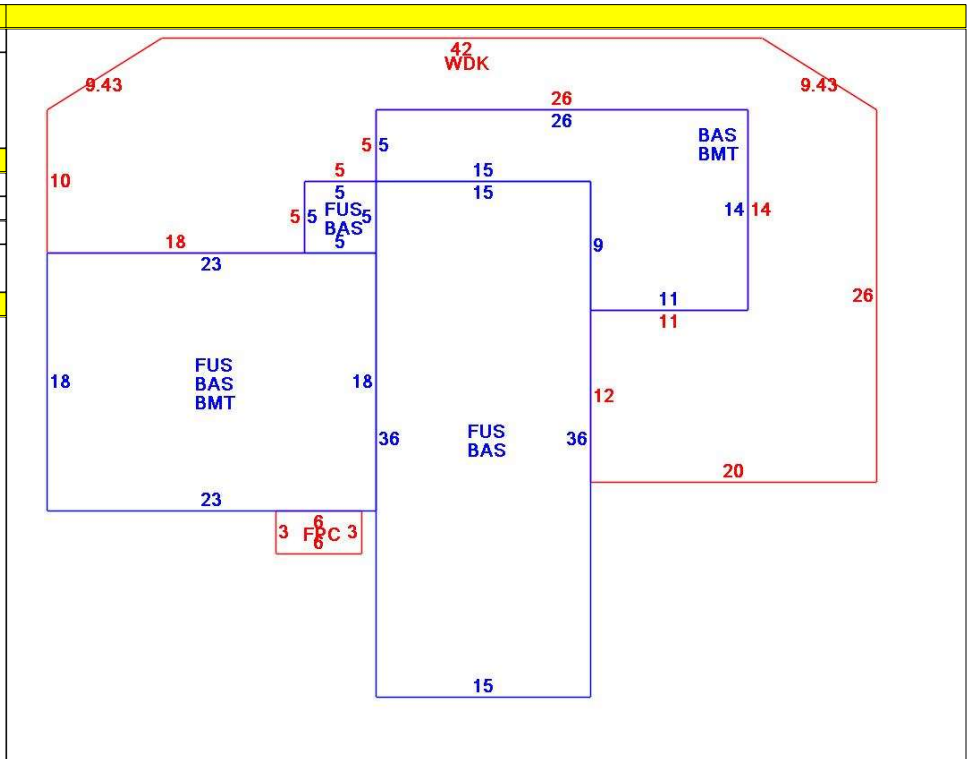

| OB - OUTBUILDING & YARD ITEMS(L) / XF - BUILDING EXTRA FEATURES(B) |                 |     |       |            |        |          |      |       |            |             |
|--|-----------------|-----|-------|------------|--------|----------|------|-------|------------|-------------|
| Code   | Description     | L/B | Units | Unit Price | Yr Blt | Cond. Cd | % Gd | Grade | Grade Adj. | Appr. Value |
| FPL3   | Fireplace 2 sto | B   | 1     | 7000.00    | 1992   |          | 77   |       | 0.00       | 5,400       |
| WDC  | Deck comp w     | L   | 821   | 28.00      | 2016   |          | 94   |       | 0.00       | 19,600      |
| FOPC   | Open Prch-roo   | B   | 18    | 55.00      | 1992   |          | 77   |       | 0.00       | 1,100       |
| BMT  | Basement-Unfi   | B   | 643   | 26.01      | 1992   |          | 77   |       | 0.00       | 15,400      |

| BUILDING SUB-AREA SUMMARY SECTION |                        |             |            |          |           |                |
|-----------------------------------|------------------------|-------------|------------|----------|-----------|----------------|
| Code                              | Description            | Living Area | Floor Area | Eff Area | Unit Cost | Undeprec Value |
| BAS                               | First Floor            | 1,208       | 1,208      | 1,208    | 301.42    | 364,118        |
| BMT                               | Basement Area          | 0           | 643        | 0        | 0.00      | 0              |
| FPC                               | Open Porch Conc. Floor | 0           | 18         | 0        | 0.00      | 0              |
| FUS                               | Upper Story            | 979         | 979        | 979      | 301.42    | 295,092        |
| WDK                               | Wood Deck              | 0           | 821        | 0        | 0.00      | 0              |
| Ttl Gross Liv / Lease Area        |                        | 2,187       | 3,669      | 2,187    |           | 659,210        |

