

| CURRENT OWNER | | TOPO | UTILITIES | STRT / ROAD | LOCATION | CURRENT ASSESSMENT | | | | 801 FY2024 BARNSTABLE, MA VISION | |
|--|--|---------|----------------|--|----------|--------------------|------|----------|----------|--|---------|
| QUEENEY, ELLEN L 129 PARK AVENUE CENTERVILLE MA 02632 | | 1 Level | 2 Public Water | 1 Paved | | Description | Code | Assessed | Assessed | | |
| | | | 4 Gas | | | RESIDNTL | 1010 | 378,000 | 378,000 | | |
| | | | 6 Septic | | | RES LAND | 1010 | 320,100 | 320,100 | | |
| SUPPLEMENTAL DATA | | | | | | Total | | | | 698,100 | 698,100 |
| Alt Prcl ID Split Zonin BID Parcel ResExpt Q #DL 1 LOT 22 & 20-FT STRIP OF #DL 2 GIS ID F_970426_2698465 | | | | Plan Ref. 21/133 Land Ct# #SR Life Estate PP STATU Assoc Pid# | | | | | | | |

| RECORD OF OWNERSHIP | | BK-VOL/PAGE | SALE DATE | Q/U | V/I | SALE PRIC | VC | PREVIOUS ASSESSMENTS (HISTORY) | | | | | | | | |
|---------------------------------|-------|-------------|------------|-----|-----|-----------|----|--------------------------------|------|----------|------|---------|----------|-------|--|---------|
| QUEENEY, ELLEN L | 32926 | 0300 | 05-22-2020 | U | I | 1 | 1F | Year | Code | Assessed | Year | Code | Assessed | | | |
| QUEENEY, ELLEN L & ADELAIDE M | 29825 | 0126 | 07-28-2016 | Q | I | 373,000 | 00 | 2023 | 1010 | 336,200 | 2022 | 1010 | 277,500 | | | |
| CONNORS, THOMAS F SR & SANDRA L | 10742 | 0264 | 05-09-1997 | Q | I | 156,000 | 00 | | 1010 | 297,600 | | 1010 | 205,800 | | | |
| WILCOX, HOWARD J & KAREN T | 9095 | 0114 | 03-15-1994 | Q | I | 142,000 | U | | | | | 1010 | 2,900 | | | |
| EICHMAN, EDWARD J & SALLY J | 7919 | 0257 | 03-16-1992 | Q | I | 123,500 | U | | | | | | | | | |
| Total | | | | | | | | 633,800 | | Total | | 483,300 | | Total | | 422,600 |

| EXEMPTIONS | | | OTHER ASSESSMENTS | | | | This signature acknowledges a visit by a Data Collector or Assessor | | | | | | | | |
|------------|------|-------------|-------------------|------|-------------|--------|---|----------|--|--|--|--|--|--|--|
| Year | Code | Description | Amount | Code | Description | Number | Amount | Comm Int | | | | | | | |
| | | | | | | | | | | | | | | | |
| Total | | | 0.00 | | | | | | | | | | | | |

| ASSESSING NEIGHBORHOOD | | | | APPRAISED VALUE SUMMARY | | | |
|------------------------|-----------|---|---------|-------------------------|-------------------------------|---------|--|
| Nbhd | Nbhd Name | B | Tracing | Batch | | | |
| 0109 | | | | CENVIL | Appraised Bldg. Value (Card) | 364,000 | |
| | | | | | Appraised Xf (B) Value (Bldg) | 5,700 | |
| | | | | | Appraised Ob (B) Value (Bldg) | 8,300 | |
| | | | | | Appraised Land Value (Bldg) | 320,100 | |
| | | | | | Special Land Value | 0 | |
| | | | | | Total Appraised Parcel Value | 698,100 | |
| | | | | | Valuation Method | C | |
| | | | | | Total Appraised Parcel Value | 698,100 | |

| NOTES | | | | | | | | VISIT / CHANGE HISTORY | | | | | | | |
|-----------|------------|------|-------------|--------|------------|--------|------------|------------------------|------------|----|------|----|----|----------------------------|--|
| Permit Id | Issue Date | Type | Description | Amount | Insp Date | % Comp | Date Comp | Comments | Date | Id | Type | Is | Cd | Purpost/Result | |
| 35291 | 10-10-1998 | AD | Addition | 28,500 | 05-30-2000 | 100 | 01-01-2000 | | 03-12-2021 | SR | 01 | | 03 | Cycl Insp Comp | |
| | | | | | | | | | 05-18-2020 | WD | | | FR | Field Review | |
| | | | | | | | | | 09-04-2009 | PT | 02 | | 14 | Cyclical Inspection | |
| | | | | | | | | | 09-19-2001 | PT | 01 | | 00 | Meas/Listed-Interior Acces | |
| | | | | | | | | | 05-30-2000 | DD | 02 | | 02 | Bldg Permit Completed | |
| | | | | | | | | | 12-15-1988 | ME | 02 | | 01 | Meas/Est | |

| LAND LINE VALUATION SECTION | | | | | | | | | | | | | | | | | |
|-----------------------------|----------|----------------|------|----|------------|------------|------------------------|---------|------------|-------|-------|-----------|------------------|--------------------|------------|------------|---------|
| B | Use Code | Description | Zone | LA | Land Units | Unit Price | Size Adj | AC Disc | Site Index | Cond. | Nbhd. | Nbhd. Adj | Notes | Location Adjustmen | Adj Unit P | Land Value | |
| 1 | 1010 | Single Fam M-0 | RD- | 3 | 0.220 | AC | 176,344.00 | 3.75053 | 1.0000 | 5 | 1.00 | 0109 | 2.200 | | 1.0000 | 1,455,049 | 320,100 |
| Total Card Land Units | | | | | 0.22 | AC | Parcel Total Land Area | | | | | 0.22 | Total Land Value | | | | 320,100 |

| CONSTRUCTION DETAIL | | | CONSTRUCTION DETAIL (CONTINUED) | | |
|---------------------|----|----------------|---------------------------------|------|-------------|
| Element | Cd | Description | Element | Cd | Description |
| Style | 04 | Cape Cod | | | |
| Model | 01 | Residential | | | |
| Grade: | C+ | Average Plus | | | |
| Stories | 1 | 1 Story | | | |
| Exterior Wall 1 | 14 | Wood Shingle | | | |
| Exterior Wall 2 | | | | | |
| Roof Structure | 11 | Bowstring Trus | | | |
| Roof Cover | 03 | Asph/F Gls/Cmp | | | |
| Interior Wall 1 | 05 | Drywall | | | |
| Interior Wall 2 | | | | | |
| Interior Floor 1 | 14 | Carpet | | | |
| Interior Floor 2 | 12 | Hardwood | | | |
| Heat Fuel | 03 | Gas | | | |
| Heat Type | 04 | Hot Air | | | |
| AC Type | 01 | None | | | |
| Bedrooms | 02 | 2 Bedrooms | | | |
| Full Baths | 2 | | | | |
| Half Baths | 0 | | | | |
| Extra Fixtures | | | | | |
| Total Rooms | 5 | 5 Rooms | | | |
| Bath Style | | | | | |
| Kitchen Style | | | | | |
| Occupancy | | | | | |
| Usrflid 105 | | | | | |
| Accessory Apt | | | | | |
| Foundation Alt | 02 | Conc. Block | | | |
| Rms Prts | | | | | |
| Bath Split | 20 | 2 Full-0 Half | | | |
| | | | CONDO DATA | | |
| | | | Parcel Id | C | Owne 0.0 |
| | | | | B | S |
| | | | Adjust Type | Code | Description |
| | | | Condo Flr | | Factor% |
| | | | Condo Unit | | |
| | | | COST / MARKET VALUATION | | |
| | | | Building Value New | | 478,895 |
| | | | Year Built | | 1955 |
| | | | Effective Year Built | | 1988 |
| | | | Depreciation Code | | G |
| | | | Remodel Rating | | |
| | | | Year Remodeled | | |
| | | | Depreciation % | | 24 |
| | | | Functional Obsol | | 0 |
| | | | External Obsol | | 0 |
| | | | Trend Factor | | 1 |
| | | | Condition | | |
| | | | Condition % | | |
| | | | Percent Good | | 76 |
| | | | RCNLD | | 364,000 |
| | | | Dep % Ovr | | |
| | | | Dep Ovr Comment | | |
| | | | Misc Imp Ovr | | |
| | | | Misc Imp Ovr Comment | | |
| | | | Cost to Cure Ovr | | |
| | | | Cost to Cure Ovr Comment | | |

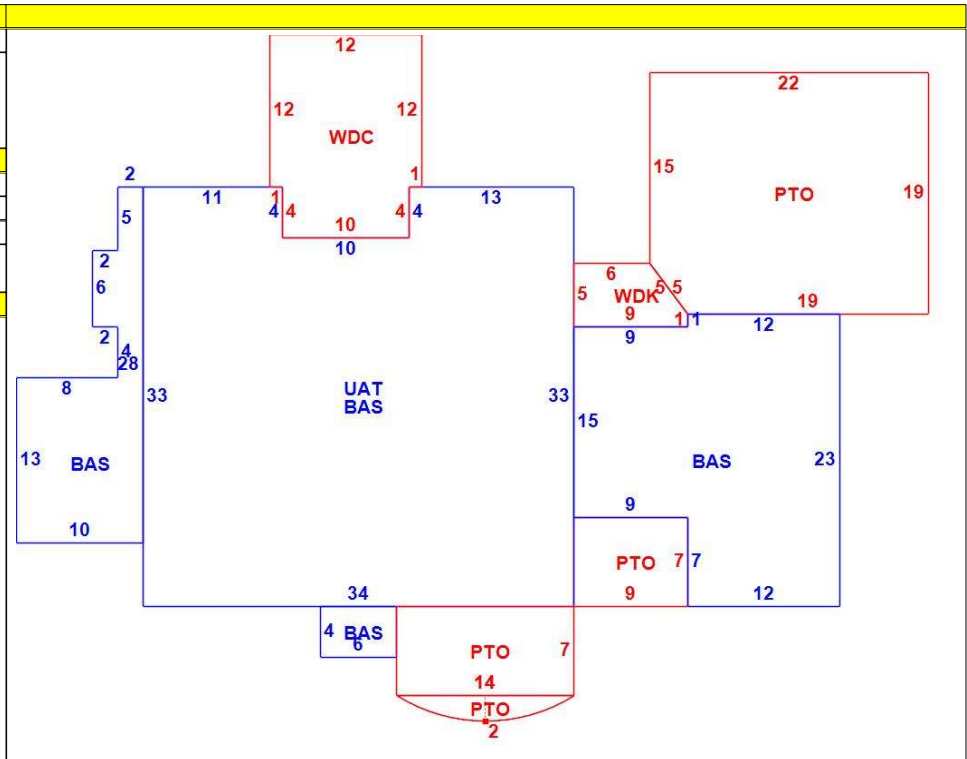

| OB - OUTBUILDING & YARD ITEMS(L) / XF - BUILDING EXTRA FEATURES(B) | | | | | | | | | | |
|--|-----------------|-----|-------|------------|--------|----------|------|-------|------------|-------------|
| Code | Description | L/B | Units | Unit Price | Yr Blt | Cond. Cd | % Gd | Grade | Grade Adj. | Appr. Value |
| FPL1 | Fireplace 1 sto | B | 1 | 5000.00 | 1990 | | 76 | | 0.00 | 3,800 |
| WDC | Wood Decking | L | 39 | 20.00 | 1992 | | 46 | | 0.00 | 1,100 |
| PAT2 | Patio-Good | L | 592 | 9.94 | 1992 | | 73 | | 0.00 | 4,100 |
| FPLG | Gas Fireplace- | B | 1 | 2500.00 | 1990 | | 76 | | 0.00 | 1,900 |
| WDC | Wood Deck w/ | L | 184 | 18.00 | 1996 | | 54 | | 0.00 | 2,200 |
| SHED | Shed | L | 96 | 18.00 | 1996 | | 54 | | 0.00 | 900 |

| BUILDING SUB-AREA SUMMARY SECTION | | | | | | |
|-----------------------------------|-------------------|-------------|------------|----------|-----------|----------------|
| Code | Description | Living Area | Floor Area | Eff Area | Unit Cost | Undeprec Value |
| BAS | First Floor | 1,689 | 1,689 | 1,689 | 266.50 | 450,113 |
| PTO | Patio | 0 | 592 | 0 | 0.00 | 0 |
| UAT | Attic, Unfinished | 0 | 1,082 | 108 | 26.60 | 28,782 |
| WDC | WDC | 0 | 184 | 0 | 0.00 | 0 |
| WDK | Wood Deck | 0 | 39 | 0 | 0.00 | 0 |
| Ttl Gross Liv / Lease Area | | 1,689 | 3,586 | 1,797 | | 478,895 |

