

| CURRENT OWNER   |  | TOPO | UTILITIES | STRT / ROAD  | LOCATION | CURRENT ASSESSMENT |      |          |          |                                 |
|---|--|------|-----------|--|----------|--------------------|------|----------|----------|---------------------------------|
| JONES, ROBERT R & RITA R  |  |      |           |  |          | Description        | Code | Assessed | Assessed | 801<br>FY2024<br>BARNSTABLE, MA |
| 65 PINEWOOD RD  |  |      |           |  |          | RESIDNTL           | 1010 | 249,400  | 249,400  |                                 |
| HYANNIS MA 02601  |  |      |           |  |          | RES LAND           | 1010 | 210,400  | 210,400  | <b>VISION</b>                   |
| SUPPLEMENTAL DATA   |  |      |           |  |          | Total              |      |          |          |                                 |
| Alt Prcl ID<br>Split Zonin<br>BID Parcel<br>ResExpt Q<br>#DL 1 LOT 9A<br>#DL 2<br>GIS ID F_971715_2700164 |  |      |           | Plan Ref. 143/39<br>Land Ct#<br>#SR<br>Life Estate<br>PP STATU<br>Assoc Pid# |          |                    |      |          |          |                                 |

| RECORD OF OWNERSHIP      |  | BK-VOL/PAGE | SALE DATE | Q/U        | V/I | SALE PRIC | VC | PREVIOUS ASSESSMENTS (HISTORY) |       |      |          |       |      |          |       |      |          |
|--------------------------|--|-------------|-----------|------------|-----|-----------|----|--------------------------------|-------|------|----------|-------|------|----------|-------|------|----------|
| JONES, ROBERT R & RITA R |  | P1469-E1    | 0         | 11-15-1991 | U   | I         | 0  | 1A                             | Year  | Code | Assessed | Year  | Code | Assessed | Year  | Code | Assessed |
| JONES, LESTER A          |  | 3125        | 0005      | 07-16-1980 | U   |           | 0  |                                | 2023  | 1010 | 215,800  | 2022  | 1010 | 187,400  | 2021  | 1010 | 152,200  |
|                          |  |             |           |            |     |           |    |                                |       | 1010 | 191,300  |       | 1010 | 131,600  |       | 1010 | 133,600  |
|                          |  |             |           |            |     |           |    |                                |       |      |          |       |      |          |       | 1010 | 3,700    |
|                          |  |             |           |            |     |           |    |                                | Total |      | 407,100  | Total |      | 319,000  | Total |      | 289,500  |

| EXEMPTIONS |      |             |        | OTHER ASSESSMENTS |             |        |        | This signature acknowledges a visit by a Data Collector or Assessor |  |  |  |  |  |  |  |  |  |  |
|------------|------|-------------|--------|-------------------|-------------|--------|--------|---|--|--|--|--|--|--|--|--|--|--|
| Year       | Code | Description | Amount | Code              | Description | Number | Amount | Comm Int  |  |  |  |  |  |  |  |  |  |  |
|            |      |             |        |                   |             |        |        |   |  |  |  |  |  |  |  |  |  |  |
| Total      |      |             | 0.00   |                   |             |        |        |   |  |  |  |  |  |  |  |  |  |  |

| ASSESSING NEIGHBORHOOD |           |   |         | APPRAISED VALUE SUMMARY              |  |  |  |  |  |  |  |  |  |  |
|------------------------|-----------|---|---------|--------------------------------------|--|--|--|--|--|--|--|--|--|--|
| Nbhd                   | Nbhd Name | B | Tracing | Batch                                |  |  |  |  |  |  |  |  |  |  |
| 0107                   |           |   |         | CENVIL                               |  |  |  |  |  |  |  |  |  |  |
| NOTES                  |           |   |         | Appraised Bldg. Value (Card) 211,300 |  |  |  |  |  |  |  |  |  |  |
|                        |           |   |         | Appraised Xf (B) Value (Bldg) 34,400 |  |  |  |  |  |  |  |  |  |  |
|                        |           |   |         | Appraised Ob (B) Value (Bldg) 3,700  |  |  |  |  |  |  |  |  |  |  |
|                        |           |   |         | Appraised Land Value (Bldg) 210,400  |  |  |  |  |  |  |  |  |  |  |
|                        |           |   |         | Special Land Value 0                 |  |  |  |  |  |  |  |  |  |  |
|                        |           |   |         | Total Appraised Parcel Value 459,800 |  |  |  |  |  |  |  |  |  |  |
|                        |           |   |         | Valuation Method C                   |  |  |  |  |  |  |  |  |  |  |
|                        |           |   |         | Total Appraised Parcel Value 459,800 |  |  |  |  |  |  |  |  |  |  |

| BUILDING PERMIT RECORD |            |      |             |        |            |        |            |                | VISIT / CHANGE HISTORY |    |      |    |    |                  |
|------------------------|------------|------|-------------|--------|------------|--------|------------|----------------|------------------------|----|------|----|----|------------------|
| Permit Id              | Issue Date | Type | Description | Amount | Insp Date  | % Comp | Date Comp  | Comments       | Date                   | Id | Type | Is | Cd | Purpost/Result   |
| 201505201              | 08-27-2015 | IN   | Insulation  | 4,700  | 06-30-2016 | 100    | 06-30-2016 | WEATHERIZATION | 06-05-2020             | LS |      |    | FR | Field Review     |
|                        |            |      |             |        |            |        |            |                | 06-05-2017             | KM | 02   |    | 03 | Cycl Insp Comp   |
|                        |            |      |             |        |            |        |            |                | 04-05-2016             | AL | 03   |    | 16 | In Office Review |
|                        |            |      |             |        |            |        |            |                | 09-05-2012             | TR | 03   |    | 16 | In Office Review |

| LAND LINE VALUATION SECTION |          |                |      |    |            |            |                        |         |            |       |       |           |                  |                    |            |            |         |
|-----------------------------|----------|----------------|------|----|------------|------------|------------------------|---------|------------|-------|-------|-----------|------------------|--------------------|------------|------------|---------|
| B                           | Use Code | Description    | Zone | LA | Land Units | Unit Price | Size Adj               | AC Disc | Site Index | Cond. | Nbhd. | Nbhd. Adj | Notes            | Location Adjustmen | Adj Unit P | Land Value |         |
| 1                           | 1010     | Single Fam M-0 | RC   | 3  | 0.290      | AC         | 176,344.00             | 2.93869 | 1.0000     | 5     | 1.00  | 0107      | 1.400            |                    | 1.0000     | 725,514.4  | 210,400 |
| Total Card Land Units       |          |                |      |    | 0.29       | AC         | Parcel Total Land Area |         |            |       |       | 0.29      | Total Land Value |                    |            | 210,400    |         |

| CONSTRUCTION DETAIL |    |                | CONSTRUCTION DETAIL (CONTINUED) |    |             |
|---------------------|----|----------------|---------------------------------|----|-------------|
| Element             | Cd | Description    | Element                         | Cd | Description |
| Style               | 01 | Ranch          |                                 |    |             |
| Model               | 01 | Residential    |                                 |    |             |
| Grade:              | C  | Average        |                                 |    |             |
| Stories             | 1  | 1 Story        |                                 |    |             |
| Exterior Wall 1     | 19 | Brick Veneer   |                                 |    |             |
| Exterior Wall 2     | 14 | Wood Shingle   |                                 |    |             |
| RooF Structure      | 03 | Gable/Hip      |                                 |    |             |
| RooF Cover          | 03 | Asph/F Gls/Cmp |                                 |    |             |
| Interior Wall 1     | 07 | Knotty Pine    |                                 |    |             |
| Interior Wall 2     |    |                |                                 |    |             |
| Interior Floor 1    | 14 | Carpet         |                                 |    |             |
| Interior Floor 2    |    |                |                                 |    |             |
| Heat Fuel           | 03 | Gas            |                                 |    |             |
| Heat Type           | 09 | Typical        |                                 |    |             |
| AC Type             | 01 | None           |                                 |    |             |
| Bedrooms            | 02 | 2 Bedrooms     |                                 |    |             |
| Full Baths          | 1  |                |                                 |    |             |
| Half Baths          | 0  |                |                                 |    |             |
| Extra Fixtures      |    |                |                                 |    |             |
| Total Rooms         | 5  | 5 Rooms        |                                 |    |             |
| Bath Style          |    |                |                                 |    |             |
| Kitchen Style       |    |                |                                 |    |             |
| Occupancy           |    |                |                                 |    |             |
| Usrflid 105         |    |                |                                 |    |             |
| Accessory Apt       |    |                |                                 |    |             |
| Foundation Alt      | 01 | Poured Conc.   |                                 |    |             |
| Rms Prts            |    |                |                                 |    |             |
| Bath Split          | 10 | 1 Full-0 Half  |                                 |    |             |

| CONDO DATA  |      |             |         |     |
|-------------|------|-------------|---------|-----|
| Parcel Id   |      | C           | Owne    | 0.0 |
|             |      |             |         |     |
| Adjust Type | Code | Description | Factor% |     |
| Condo Flr   |      |             |         |     |
| Condo Unit  |      |             |         |     |

| COST / MARKET VALUATION  |  |         |
|--------------------------|--|---------|
| Building Value New       |  | 285,521 |
| Year Built               |  | 1959    |
| Effective Year Built     |  | 1985    |
| Depreciation Code        |  | A       |
| Remodel Rating           |  |         |
| Year Remodeled           |  |         |
| Depreciation %           |  | 26      |
| Functional Obsol         |  | 0       |
| External Obsol           |  | 0       |
| Trend Factor             |  | 1       |
| Condition                |  |         |
| Condition %              |  |         |
| Percent Good             |  | 74      |
| RCNLD                    |  | 211,300 |
| Dep % Ovr                |  |         |
| Dep Ovr Comment          |  |         |
| Misc Imp Ovr             |  |         |
| Misc Imp Ovr Comment     |  |         |
| Cost to Cure Ovr         |  |         |
| Cost to Cure Ovr Comment |  |         |

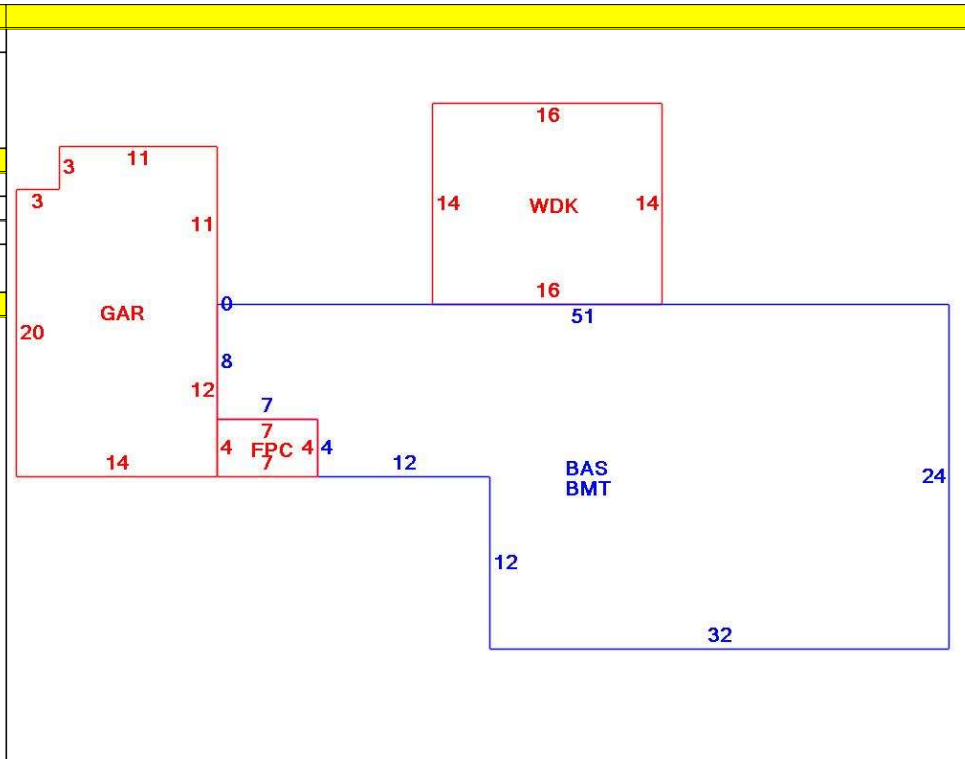

| OB - OUTBUILDING & YARD ITEMS(L) / XF - BUILDING EXTRA FEATURES(B) |                 |     |       |            |        |          |      |       |            |             |
|--|-----------------|-----|-------|------------|--------|----------|------|-------|------------|-------------|
| Code   | Description     | L/B | Units | Unit Price | Yr Blt | Cond. Cd | % Gd | Grade | Grade Adj. | Appr. Value |
| FPL1   | Fireplace 1 sto | B   | 1     | 5000.00    | 1987   |          | 74   |       | 0.00       | 3,700       |
| WDC  | Wood Decking    | L   | 224   | 20.00      | 1993   |          | 74   |       | 0.00       | 3,700       |
| FOPC   | Open Prch-roo   | B   | 28    | 55.00      | 1987   |          | 74   |       | 0.00       | 1,400       |
| GAR  | Attached Gara   | B   | 313   | 40.00      | 1987   |          | 74   |       | 0.00       | 10,200      |
| BMT  | Basement-Unfi   | B   | 960   | 26.01      | 1987   |          | 74   |       | 0.00       | 19,100      |

| BUILDING SUB-AREA SUMMARY SECTION |                        |             |            |          |           |                |
|-----------------------------------|------------------------|-------------|------------|----------|-----------|----------------|
| Code                              | Description            | Living Area | Floor Area | Eff Area | Unit Cost | Undeprec Value |
| BAS                               | First Floor            | 968         | 968        | 968      | 294.96    | 285,521        |
| BMT                               | Basement Area          | 0           | 968        | 0        | 0.00      | 0              |
| FPC                               | Open Porch Conc. Floor | 0           | 28         | 0        | 0.00      | 0              |
| GAR                               | Attached Garage        | 0           | 313        | 0        | 0.00      | 0              |
| WDC                               | Wood Deck              | 0           | 224        | 0        | 0.00      | 0              |
| Ttl Gross Liv / Lease Area        |                        | 968         | 2,501      | 968      |           | 285,521        |

