

CURRENT OWNER		TOPO	UTILITIES	STRT / ROAD	LOCATION	CURRENT ASSESSMENT				801 FY2024 BARNSTABLE, MA VISION	
GLAZEBROOK, NEIL & PAULA 23 OLD STAGE ROAD CENTERVILLE MA 02632		1 Level	2 Public Water	1 Paved		Description	Code	Assessed	Assessed		
			4 Gas			RESIDNTL	1010	796,600	796,600		
			6 Septic			RES LAND	1010	149,000	149,000		
SUPPLEMENTAL DATA						Total				945,600	945,600
Alt Prcl ID Split Zonin BID Parcel ResExpt Q #DL 1 LOT A1 & A7 #DL 2 GIS ID F_970683_2699892				Plan Ref. 287/42 Land Ct# #SR Life Estate PP STATU Assoc Pid#							

RECORD OF OWNERSHIP		BK-VOL/PAGE	SALE DATE	Q/U	V/I	SALE PRIC	VC	PREVIOUS ASSESSMENTS (HISTORY)								
Year	Code	Assessed	Year	Code	Assessed V	Year	Code	Assessed	Year	Code	Assessed					
GLAZEBROOK, NEIL & PAULA	34064	304	04-30-2021	Q	I	715,000	00									
LENNON, EDWARD & KELLY	23692	0212	05-12-2009	U	I	245,000	1	2023	1010	686,600	2022	1010	570,800	2021	1010	465,900
BARTOL, WENDY P	9282	0115	07-15-1994	Q	I	122,500	U		1010	135,400		1010	100,300		1010	100,300
WOOD, DANIEL C	8505	0023	03-15-1993	U	I	75,000	A								1010	5,700
CATALINI, JOAN	4271	0167	10-15-1984	Q	I	78,000	U									
Total								822,000	Total		671,100	Total		571,900		

EXEMPTIONS				OTHER ASSESSMENTS				This signature acknowledges a visit by a Data Collector or Assessor					
Year	Code	Description	Amount	Code	Description	Number	Amount	Comm Int					
Total			0.00										

ASSESSING NEIGHBORHOOD				APPRAISED VALUE SUMMARY				
Nbhd	Nbhd Name	B	Tracing	Batch				
0105				CENVIL	Appraised Bldg. Value (Card)	724,800		
					Appraised Xf (B) Value (Bldg)	58,000		
					Appraised Ob (B) Value (Bldg)	13,800		
					Appraised Land Value (Bldg)	149,000		
					Special Land Value	0		
					Total Appraised Parcel Value	945,600		
					Valuation Method	C		
Total Appraised Parcel Value					945,600			

NOTES									VISIT / CHANGE HISTORY					
Permit Id	Issue Date	Type	Description	Amount	Insp Date	% Comp	Date Comp	Comments	Date	Id	Type	Is	Cd	Purpost/Result
200904034	06-21-2010	RE	Remodel	9,000	06-09-2011	100	06-30-2011	BMT W 1BDRM APT	03-19-2021	SR	02		03	Cycl Insp Comp
200902114	05-14-2009	RE	Remodel	60,000	06-09-2011	100	06-30-2011	KIT,3BTHS,FLOORING,10X12	06-05-2020	LS			FR	Field Review
81173	12-09-2004	AD	Addition	250,000	12-13-2005	100	06-30-2007	PMT EXPIRED	01-11-2018	MD	22		22	Change of Address
78869	08-25-2004	AD	Addition	40,000	07-21-2005	100	01-01-2005	FNDN UNDER EXIST	04-05-2016	AL	03		16	In Office Review
17025	08-02-1996	RE	Remodel	25,000	08-05-1997	100	01-01-1997		01-28-2013	DR	22		22	Change of Address
17021	08-02-1996	OB	Out Building	800	08-05-1997	100	01-01-1997	6X8 SHED	08-01-2011	RB	03		02	Bldg Permit Completed
									03-07-2007	JG			21	Remodeled

LAND LINE VALUATION SECTION																	
B	Use Code	Description	Zone	LA	Land Units	Unit Price	Size Adj	AC Disc	Site Index	Cond.	Nbhd.	Nbhd. Adj	Notes	Location Adjustmen	Adj Unit P	Land Value	
1	1010	Single Fam M-0	RD-	3	0.250	AC	176,344.00	3.37919	1.0000	5	1.00	0105	1.000		1.0000	595,901.6	149,000
Total Card Land Units					0.25	AC	Parcel Total Land Area					0.25	Total Land Value			149,000	

CONSTRUCTION DETAIL			CONSTRUCTION DETAIL (CONTINUED)		
Element	Cd	Description	Element	Cd	Description
Style	06	Conventional			
Model	01	Residential			
Grade:	B	Custom			
Stories	1.5	1 1/2 Stories			
Exterior Wall 1	14	Wood Shingle			
Exterior Wall 2	11	Clapboard			
Roof Structure	03	Gable/Hip			
Roof Cover	03	Asph/F Gls/Cmp			
Interior Wall 1	05	Drywall			
Interior Wall 2					
Interior Floor 1	09	Pine/Soft Wood			
Interior Floor 2					
Heat Fuel	03	Gas			
Heat Type	05	Hot Water			
AC Type	03	Central			
Bedrooms	03	3 Bedrooms			
Full Baths	2				
Half Baths	0				
Extra Fixtures					
Total Rooms	7	7 Rooms			
Bath Style					
Kitchen Style					
Occupancy					
Usrflid 105					
Accessory Apt	Y	Apt here			
Foundation Alt	02	Conc. Block			
Rms Prts					
Bath Split	20	2 Full-0 Half			
			CONDO DATA		
			Parcel Id	C	Ownr 0.0
			Adjust Type	Code	Description Factor%
			Condo Flr		
			Condo Unit		
			COST / MARKET VALUATION		
			Building Value New		796,497
			Year Built		2005
			Effective Year Built		2008
			Depreciation Code		A
			Remodel Rating		
			Year Remodeled		
			Depreciation %		9
			Functional Obsol		0
			External Obsol		0
			Trend Factor		1
			Condition		
			Condition %		
			Percent Good		91
			RCNLD		724,800
			Dep % Ovr		
			Dep Ovr Comment		
			Misc Imp Ovr		
			Misc Imp Ovr Comment		
			Cost to Cure Ovr		
			Cost to Cure Ovr Comment		

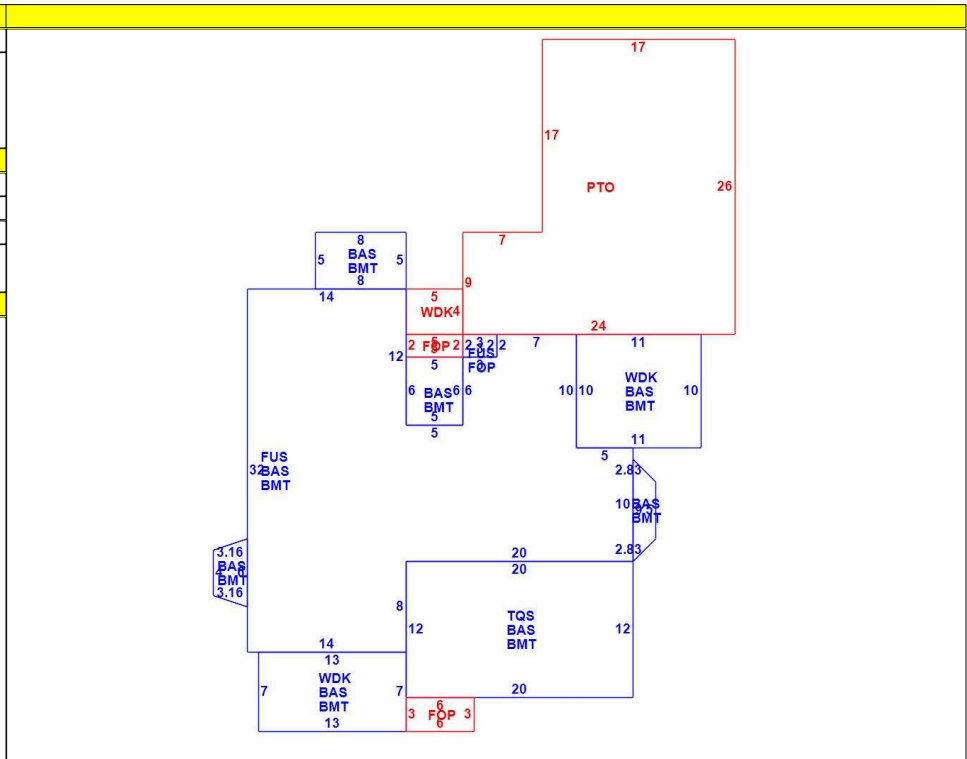

OB - OUTBUILDING & YARD ITEMS(L) / XF - BUILDING EXTRA FEATURES(B)										
Code	Description	L/B	Units	Unit Price	Yr Blt	Cond. Cd	% Gd	Grade	Grade Adj.	Appr. Value
FPL3	Fireplace 2 sto	B	1	7000.00	2010		91		0.00	6,400
BFA	Bsmt Fin-Avg	B	1,292	17.36	2010		91		0.00	20,400
WDC	Wood Decking	L	221	20.00	2008		78		0.00	3,900
PAT2	Patio-Good	L	505	9.94	2008		89		0.00	4,300
FOP	Open Porch-ro	B	34	55.00	2010		91		0.00	2,400
BMT	Basement-Unfi	B	1,292	26.01	2010		91		0.00	28,800
GEN	Emergency Ge	L	1	5550.00	2020		100		0.00	5,600

BUILDING SUB-AREA SUMMARY SECTION						
Code	Description	Living Area	Floor Area	Eff Area	Unit Cost	Undeprec Value
BAS	First Floor	1,292	1,292	1,292	361.06	466,489
BMT	Basement Area	0	1,292	0	0.00	0
FOP	Open Porch	0	34	0	0.00	0
FUS	Upper Story	758	758	758	361.06	273,683
PTO	Patio	0	505	0	0.00	0
TQS	Three Quarter Story	156	240	156	234.69	56,325
WDK	Wood Deck	0	221	0	0.00	0
Ttl Gross Liv / Lease Area		2,206	4,342	2,206		796,497

