

| CURRENT OWNER   |  | TOPO                    | UTILITIES    | STRT / ROAD      | LOCATION     | CURRENT ASSESSMENT |       |             |         | 801<br>FY2024<br>BARNSTABLE, MA<br><br><b>VISION</b> |          |          |
|---|--|-------------------------|--------------|------------------|--------------|--------------------|-------|-------------|---------|--|----------|----------|
| CONNORS, TIMOTHY J & DEGRAAN,<br>ROBERT & DONNA & CEFAIL, STEVE<br>30 DEAN STREET<br><br>BRAINTREE MA 02184 |  | 2                       | Above Street | 2                | Public Water | 1                  | Paved | Description | Code    |  | Assessed | Assessed |
|   |  |                         |              | 4                | Gas          |                    |       | RESIDNTL    | 1010    |  | 384,000  | 384,000  |
|   |  |                         |              | 6                | Septic       |                    |       | RES LAND    | 1010    |  | 200,900  | 200,900  |
| <b>SUPPLEMENTAL DATA</b>  |  |                         |              |                  |              | Total              |       | 584,900     | 584,900 |  |          |          |
|   |  | Alt Prcl ID             |              | Plan Ref. 233/61 |              |                    |       |             |         |  |          |          |
|   |  | Split Zonin             |              | Land Ct#         |              |                    |       |             |         |  |          |          |
|   |  | BID Parcel              |              | #SR              |              |                    |       |             |         |  |          |          |
|   |  | ResExpt Q               |              | Life Estate      |              |                    |       |             |         |  |          |          |
|   |  | #DL 1 LOT 1             |              | PP STATU         |              |                    |       |             |         |  |          |          |
|   |  | #DL 2                   |              |                  |              |                    |       |             |         |  |          |          |
|   |  | GIS ID F_972660_2701619 |              | Assoc Pid#       |              |                    |       |             |         |  |          |          |

| RECORD OF OWNERSHIP              |  | BK-VOL/PAGE | SALE DATE | Q/U        | V/I | SALE PRIC | VC      | PREVIOUS ASSESSMENTS (HISTORY) |      |         |          |         |       |          |
|----------------------------------|--|-------------|-----------|------------|-----|-----------|---------|--------------------------------|------|---------|----------|---------|-------|----------|
| CONNORS, TIMOTHY J & DEGRAAN, ME |  | 29663       | 0224      | 05-20-2016 | Q   | I         | 353,500 | 00                             | Year | Code    | Assessed | Year    | Code  | Assessed |
| JKM HOLDINGS LLC                 |  | 26189       | 0019      | 03-26-2012 | U   | I         | 10      | 1F                             | 2023 | 1010    | 340,800  | 2022    | 1010  | 286,500  |
| MARTORE, JOSEPH & GRACIA         |  | 4305        | 0285      | 11-15-1984 | Q   | I         | 117,000 | U                              |      | 1010    | 198,500  |         | 1010  | 141,200  |
| COLETTI, GUY TR                  |  | 4305        | 0284      | 11-15-1984 | U   | V         | 0       | B                              |      |         |          |         | 1010  | 4,900    |
| COLETTI, GUY                     |  | 3686        | 0288      | 03-15-1983 | Q   | V         | 22,500  | U                              |      |         |          |         |       |          |
|                                  |  | Total       |           |            |     |           |         |                                |      | 539,300 | Total    | 427,700 | Total | 382,100  |

| EXEMPTIONS |      |             |        | OTHER ASSESSMENTS |             |        |        | This signature acknowledges a visit by a Data Collector or Assessor |  |  |  |  |  |  |  |  |
|------------|------|-------------|--------|-------------------|-------------|--------|--------|---|--|--|--|--|--|--|--|--|
| Year       | Code | Description | Amount | Code              | Description | Number | Amount | Comm Int  |  |  |  |  |  |  |  |  |
|            |      |             |        |                   |             |        |        |   |  |  |  |  |  |  |  |  |
| Total      |      |             | 0.00   |                   |             |        |        |   |  |  |  |  |  |  |  |  |

| ASSESSING NEIGHBORHOOD |           |   |         | APPRAISED VALUE SUMMARY              |  |  |  |  |
|------------------------|-----------|---|---------|--------------------------------------|--|--|--|--|
| Nbhd                   | Nbhd Name | B | Tracing | Batch                                |  |  |  |  |
| 0106                   |           |   | CENVIL  |                                      |  |  |  |  |
| <b>NOTES</b>           |           |   |         | Appraised Bldg. Value (Card) 341,300 |  |  |  |  |
|                        |           |   |         | Appraised Xf (B) Value (Bldg) 31,200 |  |  |  |  |
|                        |           |   |         | Appraised Ob (B) Value (Bldg) 11,500 |  |  |  |  |
|                        |           |   |         | Appraised Land Value (Bldg) 200,900  |  |  |  |  |
|                        |           |   |         | Special Land Value 0                 |  |  |  |  |
|                        |           |   |         | Total Appraised Parcel Value 584,900 |  |  |  |  |
|                        |           |   |         | Valuation Method C                   |  |  |  |  |
|                        |           |   |         | Total Appraised Parcel Value 584,900 |  |  |  |  |

| BUILDING PERMIT RECORD |            |      |             |        |            |        |            |                          | VISIT / CHANGE HISTORY |    |      |    |    |                       |
|------------------------|------------|------|-------------|--------|------------|--------|------------|--------------------------|------------------------|----|------|----|----|-----------------------|
| Permit Id              | Issue Date | Type | Description | Amount | Insp Date  | % Comp | Date Comp  | Comments                 | Date                   | Id | Type | Is | Cd | Purpost/Result        |
| 201422746              | 05-15-2014 | IN   | Insulation  | 1,682  | 06-30-2014 | 100    | 06-30-2014 | INSULATE ATTIC ; KNEEWAL | 04-02-2021             | SR | 02   |    | 03 | Cycl Insp Comp        |
| 201000891              | 03-12-2010 | RW   | Repair Work | 75,000 | 10-04-2010 | 100    | 06-30-2011 | WATER DMG                | 06-05-2020             | LS |      |    | FR | Field Review          |
| 85512                  | 07-18-2005 | NR   | New Roof    | 7,000  |            | 100    |            |                          | 05-20-2016             | AL | 03   |    | 16 | In Office Review      |
|                        |            |      |             |        |            |        |            |                          | 03-26-2015             | JR | 03   |    | 03 | Cycl Insp Comp        |
|                        |            |      |             |        |            |        |            |                          | 05-16-2014             | JR | 03   |    | 16 | In Office Review      |
|                        |            |      |             |        |            |        |            |                          | 03-09-2011             | RB | 03   |    | 02 | Bldg Permit Completed |
|                        |            |      |             |        |            |        |            |                          | 10-04-2010             | MK | 02   |    | 52 | New Construction      |

| LAND LINE VALUATION SECTION |          |                |      |    |            |            |                        |         |            |       |       |           |                  |                    |            |            |         |
|-----------------------------|----------|----------------|------|----|------------|------------|------------------------|---------|------------|-------|-------|-----------|------------------|--------------------|------------|------------|---------|
| B                           | Use Code | Description    | Zone | LA | Land Units | Unit Price | Size Adj               | AC Disc | Site Index | Cond. | Nbhd. | Nbhd. Adj | Notes            | Location Adjustmen | Adj Unit P | Land Value |         |
| 1                           | 1010     | Single Fam M-0 | RD-  | 3  | 0.900      | AC         | 176,344.00             | 1.10079 | 1.0000     | 5     | 1.00  | 0106      | 1.150            |                    | 1.0000     | 223,233.8  | 200,900 |
| Total Card Land Units       |          |                |      |    | 0.90       | AC         | Parcel Total Land Area |         |            |       |       | 0.90      | Total Land Value |                    |            |            | 200,900 |

| CONSTRUCTION DETAIL      |      |                | CONSTRUCTION DETAIL (CONTINUED) |         |             |
|--------------------------|------|----------------|---------------------------------|---------|-------------|
| Element                  | Cd   | Description    | Element                         | Cd      | Description |
| Style                    | 04   | Cape Cod       |                                 |         |             |
| Model                    | 01   | Residential    |                                 |         |             |
| Grade:                   | C    | Average        |                                 |         |             |
| Stories                  | 1.75 | 1 3/4 Stories  |                                 |         |             |
| Exterior Wall 1          | 14   | Wood Shingle   |                                 |         |             |
| Exterior Wall 2          | 11   | Clapboard      |                                 |         |             |
| Roof Structure           | 03   | Gable/Hip      |                                 |         |             |
| Roof Cover               | 10   | Wood Shingle   |                                 |         |             |
| Interior Wall 1          | 05   | Drywall        |                                 |         |             |
| Interior Wall 2          |      |                |                                 |         |             |
| Interior Floor 1         | 09   | Pine/Soft Wood |                                 |         |             |
| Interior Floor 2         | 14   | Carpet         |                                 |         |             |
| Heat Fuel                | 02   | Oil            |                                 |         |             |
| Heat Type                | 05   | Hot Water      |                                 |         |             |
| AC Type                  | 01   | None           |                                 |         |             |
| Bedrooms                 | 04   | 4 Bedrooms     |                                 |         |             |
| Full Baths               | 2    |                |                                 |         |             |
| Half Baths               | 0    |                |                                 |         |             |
| Extra Fixtures           |      |                |                                 |         |             |
| Total Rooms              | 8    | 8 Rooms        |                                 |         |             |
| Bath Style               |      |                |                                 |         |             |
| Kitchen Style            |      |                |                                 |         |             |
| Occupancy                |      |                |                                 |         |             |
| Usrflid 105              |      |                |                                 |         |             |
| Accessory Apt            |      |                |                                 |         |             |
| Foundation Alt           | 01   | Poured Conc.   |                                 |         |             |
| Rms Prts                 |      |                |                                 |         |             |
| Bath Split               | 20   | 2 Full-0 Half  |                                 |         |             |
|                          |      |                | <b>CONDO DATA</b>               |         |             |
| Parcel Id                |      |                | C                               | Ownr    | 0.0         |
| Adjust Type              |      | Code           | Description                     | Factor% |             |
| Condo Flr                |      |                |                                 |         |             |
| Condo Unit               |      |                |                                 |         |             |
|                          |      |                | <b>COST / MARKET VALUATION</b>  |         |             |
| Building Value New       |      |                |                                 | 406,347 |             |
| Year Built               |      |                |                                 | 1984    |             |
| Effective Year Built     |      |                |                                 | 1998    |             |
| Depreciation Code        |      |                |                                 | A       |             |
| Remodel Rating           |      |                |                                 |         |             |
| Year Remodeled           |      |                |                                 |         |             |
| Depreciation %           |      |                |                                 | 16      |             |
| Functional Obsol         |      |                |                                 | 0       |             |
| External Obsol           |      |                |                                 | 0       |             |
| Trend Factor             |      |                |                                 | 1       |             |
| Condition                |      |                |                                 |         |             |
| Condition %              |      |                |                                 |         |             |
| Percent Good             |      |                |                                 | 84      |             |
| RCNLD                    |      |                |                                 | 341,300 |             |
| Dep % Ovr                |      |                |                                 |         |             |
| Dep Ovr Comment          |      |                |                                 |         |             |
| Misc Imp Ovr             |      |                |                                 |         |             |
| Misc Imp Ovr Comment     |      |                |                                 |         |             |
| Cost to Cure Ovr         |      |                |                                 |         |             |
| Cost to Cure Ovr Comment |      |                |                                 |         |             |

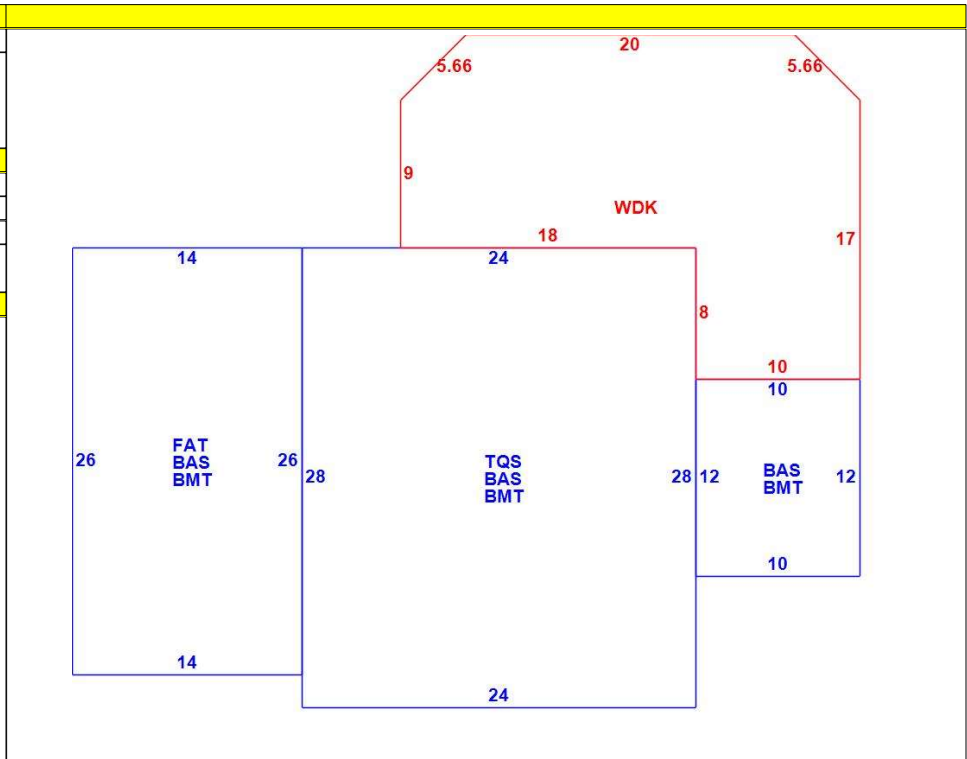

| OB - OUTBUILDING & YARD ITEMS(L) / XF - BUILDING EXTRA FEATURES(B) |                 |     |       |            |        |          |      |       |            |             |
|--|-----------------|-----|-------|------------|--------|----------|------|-------|------------|-------------|
| Code   | Description     | L/B | Units | Unit Price | Yr Blt | Cond. Cd | % Gd | Grade | Grade Adj. | Appr. Value |
| FPL2   | Fireplace 1.5 s | B   | 1     | 6000.00    | 2000   |          | 84   |       | 0.00       | 5,000       |
| FPO  | Ext FP Openin   | B   | 1     | 2000.00    | 2000   |          | 84   |       | 0.00       | 1,700       |
| WDC  | Deck comp w     | L   | 428   | 28.00      | 2020   |          | 100  |       | 0.00       | 11,500      |
| BMT  | Basement-Unfi   | B   | 1,156 | 26.01      | 2000   |          | 84   |       | 0.00       | 24,500      |

| BUILDING SUB-AREA SUMMARY SECTION |                     |             |            |          |           |                |
|-----------------------------------|---------------------|-------------|------------|----------|-----------|----------------|
| Code                              | Description         | Living Area | Floor Area | Eff Area | Unit Cost | Undeprec Value |
| BAS                               | First Floor         | 1,156       | 1,156      | 1,156    | 246.57    | 285,035        |
| BMT                               | Basement Area       | 0           | 1,156      | 0        | 0.00      | 0              |
| FAT                               | Attic, Finished     | 55          | 364        | 55       | 37.26     | 13,561         |
| TQS                               | Three Quarter Story | 437         | 672        | 437      | 160.34    | 107,751        |
| WDK                               | Wood Deck           | 0           | 428        | 0        | 0.00      | 0              |
| Ttl Gross Liv / Lease Area        |                     | 1,648       | 3,776      | 1,648    |           | 406,347        |

