

CURRENT OWNER		TOPO	UTILITIES	STRT / ROAD	LOCATION	CURRENT ASSESSMENT			
BAKER, MARIE-ANNE TR BAKER FAMILY TRUST 25 EILEEN DR BRAINTREE MA 02184		1 Level	2 Public Water	1 Paved		Description	Code	Assessed	Assessed
			4 Gas			RESIDNTL	1010	451,900	451,900
			6 Septic			RES LAND	1010	239,300	239,300
SUPPLEMENTAL DATA									
		Alt Prcl ID		Plan Ref. 126/103					
		Split Zonin		Land Ct#					
		BID Parcel		#SR					
		ResExpt Q		Life Estate					
		#DL 1 LOT 40		PP STATU					
		#DL 2		Assoc Pid#					
		GIS ID F_970881_2704703							
						Total		691,200	691,200

801
 FY2024
 BARNSTABLE, MA
VISION

RECORD OF OWNERSHIP		BK-VOL/PAGE	SALE DATE	Q/U	V/I	SALE PRIC	VC	PREVIOUS ASSESSMENTS (HISTORY)					
BAKER, MARIE-ANNE TR		10513 0313	12-06-1996	Q	I	133,000	00	Year	Code	Assessed	Year	Code	Assessed
LESHAN, LAWRENCE L & EDA J		8312 0097	11-18-1992	Q	I	144,000	U	2023	1010	391,800	2022	1010	336,400
HOUSE, EDWARD A & BARBARA R		5677 0038	04-22-1987	Q	I	157,000	U		1010	236,700		1010	151,700
ROBBINS, JAMES JR & GAYLENE K		2758 0241	08-02-1978	U		0						1010	3,100
						Total		628,500	Total	488,100	Total	435,500	

EXEMPTIONS			OTHER ASSESSMENTS					
Year	Code	Description	Amount	Code	Description	Number	Amount	Comm Int
		Total	0.00					

This signature acknowledges a visit by a Data Collector or Assessor

ASSESSING NEIGHBORHOOD				
Nbhd	Nbhd Name	B	Tracing	Batch
0108				CENVIL

NOTES			

APPRAISED VALUE SUMMARY	
Appraised Bldg. Value (Card)	407,100
Appraised Xf (B) Value (Bldg)	41,700
Appraised Ob (B) Value (Bldg)	3,100
Appraised Land Value (Bldg)	239,300
Special Land Value	0
Total Appraised Parcel Value	691,200
Valuation Method	C
Total Appraised Parcel Value	691,200

BUILDING PERMIT RECORD								VISIT / CHANGE HISTORY						
Permit Id	Issue Date	Type	Description	Amount	Insp Date	% Comp	Date Comp	Comments	Date	Id	Type	Is	Cd	Purpost/Result
201307118	10-18-2013	RE	Remodel	30,000	07-28-2014	100	06-30-2014	RENO BTH,KIT-CUT OPENIN	04-17-2020	WD			FR	Field Review
									08-06-2014	MW	02		02	Bldg Permit Completed
									06-02-2014	MW	02		13	CALL BACK
									09-30-2009	PT	02		14	Cyclical Inspection
									12-01-2000	PT	01		00	Meas/Listed-Interior Acces

LAND LINE VALUATION SECTION																	
B	Use Code	Description	Zone	LA	Land Units	Unit Price	Size Adj	AC Disc	Site Index	Cond.	Nbhd.	Nbhd. Adj	Notes	Location Adjustmen	Adj Unit P	Land Value	
1	1010	Single Fam M-0	RD-	3	0.180 AC	176,344.00	4.43465	1.0000	5	1.00	0108	1.700		1.0000	1,329,439	239,300	
Total Card Land Units					0.18 AC	Parcel Total Land Area					0.18	Total Land Value					239,300

CONSTRUCTION DETAIL			CONSTRUCTION DETAIL (CONTINUED)		
Element	Cd	Description	Element	Cd	Description
Style	01	Ranch			
Model	01	Residential			
Grade:	C+	Average Plus			
Stories	1	1 Story			
Exterior Wall 1	25	Vinyl Siding			
Exterior Wall 2					
Roof Structure	03	Gable/Hip			
Roof Cover	03	Asph/F Gls/Cmp			
Interior Wall 1	05	Drywall			
Interior Wall 2					
Interior Floor 1	14	Carpet			
Interior Floor 2	12	Hardwood			
Heat Fuel	03	Gas			
Heat Type	05	Hot Water			
AC Type	01	None			
Bedrooms	03	3 Bedrooms			
Full Baths	3				
Half Baths	0				
Extra Fixtures					
Total Rooms	6	6 Rooms			
Bath Style					
Kitchen Style					
Occupancy					
Usrflid 105					
Accessory Apt					
Foundation Alt	01	Poured Conc.			
Rms Prts					
Bath Split	30	3 Full-0 Half			

CONDO DATA				
Parcel Id		C		Ownr 0.0
			B	S
Adjust Type	Code	Description	Factor%	
Condo Flr				
Condo Unit				

COST / MARKET VALUATION	
Building Value New	502,563
Year Built	1969
Effective Year Built	1995
Depreciation Code	G
Remodel Rating	
Year Remodeled	
Depreciation %	19
Functional Obsol	0
External Obsol	0
Trend Factor	1
Condition	
Condition %	
Percent Good	81
RCNLD	407,100
Dep % Ovr	
Dep Ovr Comment	
Misc Imp Ovr	
Misc Imp Ovr Comment	
Cost to Cure Ovr	
Cost to Cure Ovr Comment	

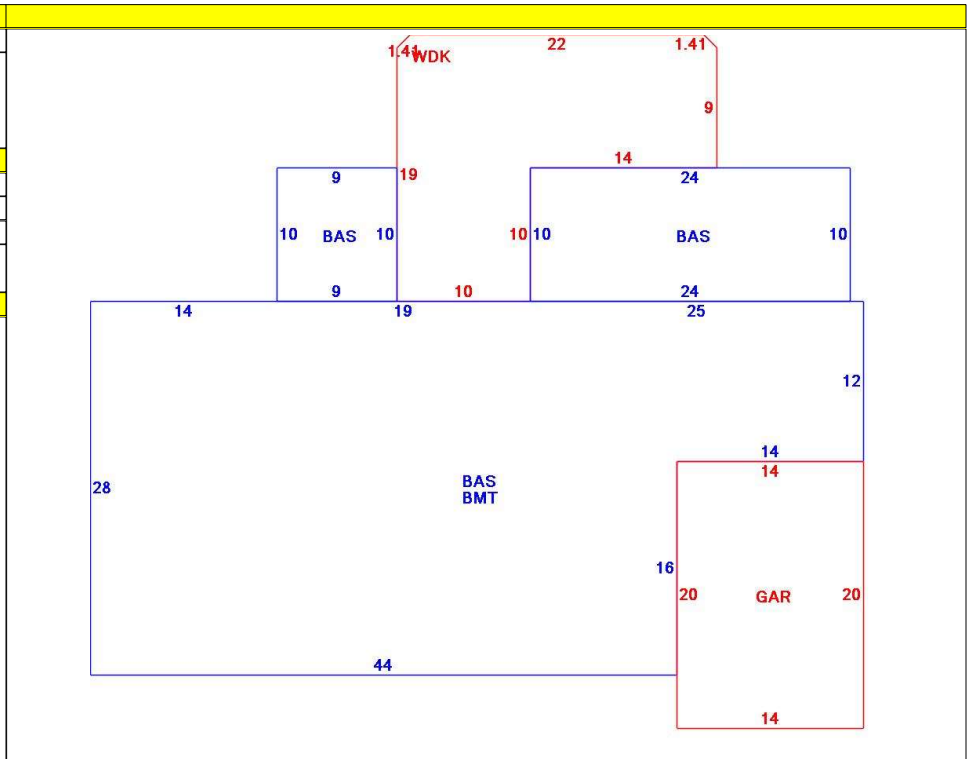

OB - OUTBUILDING & YARD ITEMS(L) / XF - BUILDING EXTRA FEATURES(B)										
Code	Description	L/B	Units	Unit Price	Yr Blt	Cond. Cd	% Gd	Grade	Grade Adj.	Appr. Value
FPL1	Fireplace 1 sto	B	1	5000.00	1997		81		0.00	4,100
WDC	Wood Deck w/	L	339	18.00	1995		52		0.00	3,100
GAR	Attached Gara	B	280	40.00	1997		81		0.00	10,300
BMT	Basement-Unfi	B	1,400	26.01	1997		81		0.00	27,300

BUILDING SUB-AREA SUMMARY SECTION						
Code	Description	Living Area	Floor Area	Eff Area	Unit Cost	Undeprec Value
BAS	First Floor	1,730	1,730	1,730	290.50	502,563
BMT	Basement Area	0	1,400	0	0.00	0
GAR	Attached Garage	0	280	0	0.00	0
WDK	Wood Deck	0	339	0	0.00	0
Ttl Gross Liv / Lease Area		1,730	3,749	1,730		502,563

