

CURRENT OWNER		TOPO	UTILITIES	STRT / ROAD	LOCATION	CURRENT ASSESSMENT			
BERGO, VLADISLAV  13 JOHNNY CAKE ROAD  CENTERVILLE MA 02632		1 Level	2 Public Water	1 Paved		Description	Code	Assessed	Assessed
			4 Gas			RESIDENTL	1010	363,200	363,200
			6 Septic			RES LAND	1010	245,400	245,400
<b>SUPPLEMENTAL DATA</b>									
Alt Prcl ID Split Zonin BID Parcel ResExpt Q NO APP: #DL 1 LOT 53 #DL 2 GIS ID F_970872_2704232				Plan Ref. 126/103 Land Ct# #SR Life Estate PP STATU Assoc Pid#		Total 608,600 608,600			

801  
FY2024  
BARNSTABLE, MA

**VISION**

RECORD OF OWNERSHIP		BK-VOL/PAGE	SALE DATE	Q/U	V/I	SALE PRIC	VC	PREVIOUS ASSESSMENTS (HISTORY)					
BERGO, VLADISLAV		34637 089	11-05-2021	Q	I	645,000	00	Year	Code	Assessed	Year	Code	Assessed
HARTMANN, ROBERT J & LOWE, JENNI		27752 0148	10-11-2013	U	I	1	1F	2023	1010	309,200	2022	1010	220,700
HARTMANN, ROBERT J		24640 0041	06-25-2010	Q	I	370,000	00		1010	242,800		1010	155,500
HILL, RYAN S		11562 0022	07-10-1998	Q	I	116,000	00					1010	3,700
EATON, WILLIAM L & NANCY S		1460 0451	01-09-1970	U		0		Total		552,000	Total		376,200
								Total			Total		330,200

EXEMPTIONS				OTHER ASSESSMENTS			
Year	Code	Description	Amount	Code	Description	Number	Amount
2023	N5C	NO RESIDENTIAL EXEMPTION	0.00				
Total			0.00				

This signature acknowledges a visit by a Data Collector or Assessor

ASSESSING NEIGHBORHOOD			
Nbhd	Nbhd Name	B	Tracing
0108			CENVIL

APPRAISED VALUE SUMMARY	
Appraised Bldg. Value (Card)	339,800
Appraised Xf (B) Value (Bldg)	19,000
Appraised Ob (B) Value (Bldg)	4,400
Appraised Land Value (Bldg)	245,400
Special Land Value	0
Total Appraised Parcel Value	608,600
Valuation Method	C
Total Appraised Parcel Value	608,600

NOTES							

BUILDING PERMIT RECORD								VISIT / CHANGE HISTORY						
Permit Id	Issue Date	Type	Description	Amount	Insp Date	% Comp	Date Comp	Comments	Date	Id	Type	Is	Cd	Purpost/Result
19-3978	11-25-2019	822	Insulation	4,900		100		Add R-38 fiberglass, R-37 cell	02-11-2021	SR	02		03	Cycl Insp Comp
201506808	10-13-2015	NR	New Roof	7,650	06-30-2016	100	06-30-2016	RE-ROOF STRIPPING OLD	04-17-2020	WD			FR	Field Review
74036	01-07-2004	AD	Addition	23,040	04-28-2005	100	01-01-2005		05-20-2011	TP	03		16	In Office Review
									04-28-2005	MF	02		02	Bldg Permit Completed
									12-01-2000	PT	01		00	Meas/Listed-Interior Acces

LAND LINE VALUATION SECTION																
B	Use Code	Description	Zone	LA	Land Units	Unit Price	Size Adj	AC Disc	Site Index	Cond.	Nbhd.	Nbhd. Adj	Notes	Location Adjustmen	Adj Unit P	Land Value
1	1010	Single Fam M-0	RD-	3	0.210 AC	176,344.00	3.89789	1.0000	5	1.00	0108	1.700		1.0000	1,168,525	245,400
Total Card Land Units					0.21	AC	Parcel Total Land Area					0.21	Total Land Value			245,400

CONSTRUCTION DETAIL			CONSTRUCTION DETAIL (CONTINUED)		
Element	Cd	Description	Element	Cd	Description
Style	01	Ranch			
Model	01	Residential			
Grade:	C+	Average Plus			
Stories	1	1 Story			
Exterior Wall 1	14	Wood Shingle			
Exterior Wall 2	11	Clapboard			
Roof Structure	03	Gable/Hip			
Roof Cover	03	Asph/F Gls/Cmp			
Interior Wall 1	05	Drywall			
Interior Wall 2					
Interior Floor 1	12	Hardwood			
Interior Floor 2	14	Carpet			
Heat Fuel	03	Gas			
Heat Type	05	Hot Water			
AC Type	03	Central			
Bedrooms	03	3 Bedrooms			
Full Baths	2				
Half Baths	0				
Extra Fixtures					
Total Rooms	6	6 Rooms			
Bath Style					
Kitchen Style					
Occupancy					
Usrflid 105					
Accessory Apt					
Foundation Alt	08	Mixed			
Rms Prts					
Bath Split	20	2 Full-0 Half			

CONDO DATA				
Parcel Id		C	Owne	0.0
Adjust Type	Code	Description	Factor%	
Condo Flr				
Condo Unit				

COST / MARKET VALUATION	
Building Value New	430,133
Year Built	1952
Effective Year Built	1992
Depreciation Code	VG
Remodel Rating	
Year Remodeled	
Depreciation %	21
Functional Obsol	0
External Obsol	0
Trend Factor	1
Condition	
Condition %	
Percent Good	79
RCNLD	339,800
Dep % Ovr	
Dep Ovr Comment	
Misc Imp Ovr	
Misc Imp Ovr Comment	
Cost to Cure Ovr	
Cost to Cure Ovr Comment	

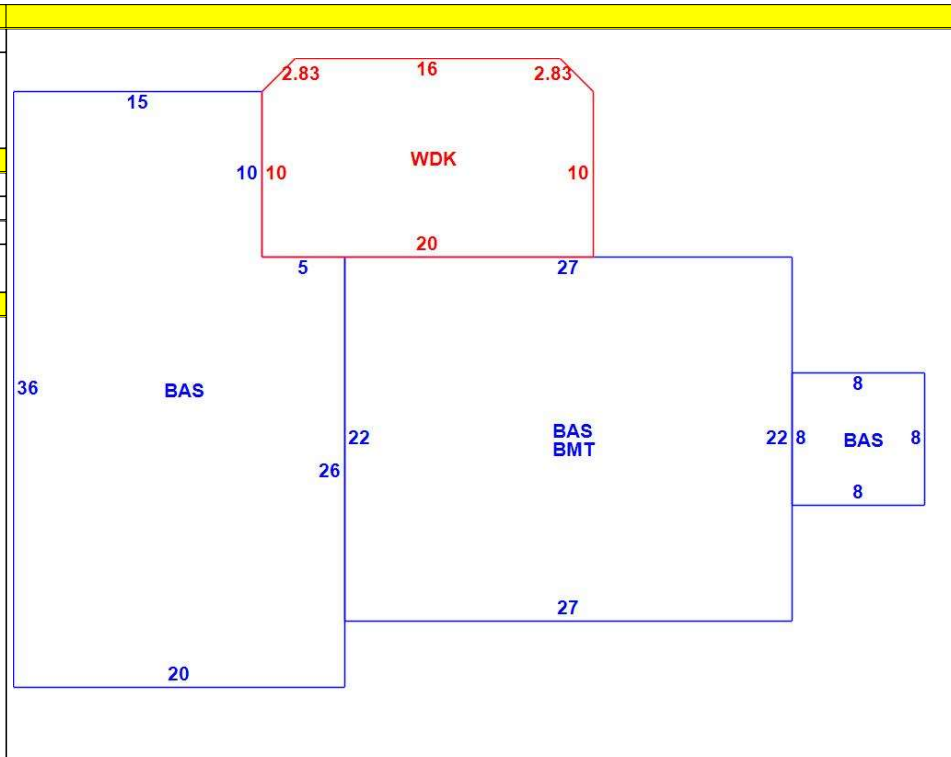

OB - OUTBUILDING & YARD ITEMS(L) / XF - BUILDING EXTRA FEATURES(B)										
Code	Description	L/B	Units	Unit Price	Yr Blt	Cond. Cd	% Gd	Grade	Grade Adj.	Appr. Value
FPL1	Fireplace 1 sto	B	1	5000.00	1984		79		0.00	4,000
SHD2	Shed w/Elec	L	192	26.00	1990		42		0.00	2,100
WDC	Wood Decking	L	236	20.00	1991		44		0.00	2,300
BMT	Basement-Unfi	B	594	26.01	1984		79		0.00	15,000

BUILDING SUB-AREA SUMMARY SECTION						
Code	Description	Living Area	Floor Area	Eff Area	Unit Cost	Undeprec Value
BAS	First Floor	1,328	1,328	1,328	323.90	430,133
BMT	Basement Area	0	594	0	0.00	0
WDK	Wood Deck	0	236	0	0.00	0
Ttl Gross Liv / Lease Area		1,328	2,158	1,328		430,133

