

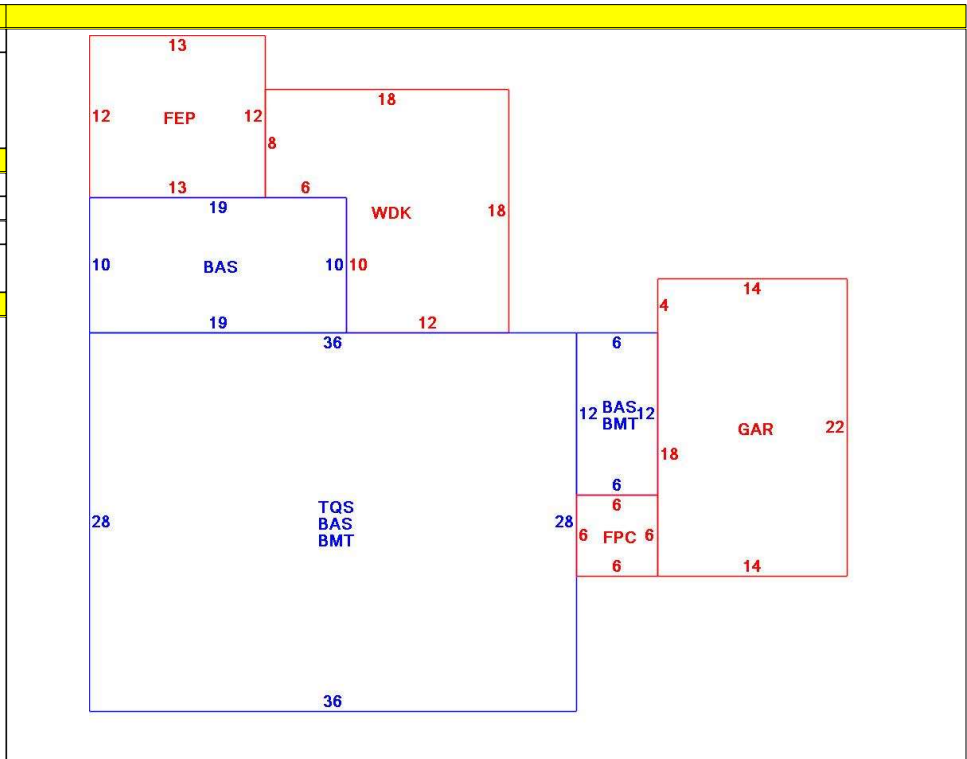

CONSTRUCTION DETAIL			CONSTRUCTION DETAIL (CONTINUED)		
Element	Cd	Description	Element	Cd	Description
Style	04	Cape Cod			
Model	01	Residential			
Grade:	C	Average			
Stories	1.75	1 3/4 Stories			
Exterior Wall 1	11	Clapboard			
Exterior Wall 2	14	Wood Shingle			
Roof Structure	03	Gable/Hip			
Roof Cover	03	Asph/F Gls/Cmp			
Interior Wall 1	05	Drywall			
Interior Wall 2					
Interior Floor 1	12	Hardwood			
Interior Floor 2	14	Carpet			
Heat Fuel	03	Gas			
Heat Type	05	Hot Water			
AC Type	01	None			
Bedrooms	03	3 Bedrooms			
Full Baths	2				
Half Baths	1				
Extra Fixtures					
Total Rooms	6	6 Rooms			
Bath Style					
Kitchen Style					
Occupancy					
Usrflid 105					
Accessory Apt					
Foundation Alt	01	Poured Conc.			
Rms Prts					
Bath Split	21	2 Full-1 Half			
			<b>CONDO DATA</b>		
			Parcel Id	C	Owne 0.0
			Adjust Type	Code	Description Factor%
			Condo Flr		
			Condo Unit		
			<b>COST / MARKET VALUATION</b>		
			Building Value New		459,921
			Year Built		1966
			Effective Year Built		1989
			Depreciation Code		A
			Remodel Rating		
			Year Remodeled		
			Depreciation %		23
			Functional Obsol		0
			External Obsol		0
			Trend Factor		1
			Condition		
			Condition %		
			Percent Good		77
			RCNLD		354,100
			Dep % Ovr		
			Dep Ovr Comment		
			Misc Imp Ovr		
			Misc Imp Ovr Comment		
			Cost to Cure Ovr		
			Cost to Cure Ovr Comment		



OB - OUTBUILDING & YARD ITEMS(L) / XF - BUILDING EXTRA FEATURES(B)										
Code	Description	L/B	Units	Unit Price	Yr Blt	Cond. Cd	% Gd	Grade	Grade Adj.	Appr. Value
FPL2	Fireplace 1.5 s	B	1	6000.00	1991		77		0.00	4,600
FPO	Ext FP Openin	B	1	2000.00	1991		77		0.00	1,500
WDC	Wood Decking	L	264	20.00	1994		50		0.00	2,800
FOPC	Open Prch-roo	B	36	55.00	1991		77		0.00	1,800
FEP	Enclosed porc	B	156	70.00	1991		77		0.00	8,300
GAR	Attached Gara	B	308	40.00	1991		77		0.00	10,500
BMT	Basement-Unfi	B	1,080	26.01	1991		77		0.00	21,500

BUILDING SUB-AREA SUMMARY SECTION						
Code	Description	Living Area	Floor Area	Eff Area	Unit Cost	Undeprec Value
BAS	First Floor	1,270	1,270	1,270	238.92	303,428
BMT	Basement Area	0	1,080	0	0.00	0
FEP	Enclosed Porch	0	156	0	0.00	0
FPC	Open Porch Conc. Floor	0	36	0	0.00	0
GAR	Attached Garage	0	308	0	0.00	0
TQS	Three Quarter Story	655	1,008	655	155.25	156,493
WDK	Wood Deck	0	264	0	0.00	0
Ttl Gross Liv / Lease Area		1,925	4,122	1,925		459,921

