

CURRENT OWNER		TOPO		UTILITIES		STRT / ROAD		LOCATION		CURRENT ASSESSMENT			
WOOD, KAREN L 19 ARNOLD STREET GREENWICH CT 06870		1	Level	4	Gas	1	Paved	1	Excel View	Description	Code	Assessed	Assessed
				5	Well					RESIDNTL	1010	513,300	513,300
				6	Septic					RES LAND	1010	209,400	209,400
SUPPLEMENTAL DATA													
Alt Prcl ID Split Zonin BID Parcel ResExpt Q NO APP: #DL 1 LOT 15 #DL 2 GIS ID F_970330_2718018						Plan Ref. 232/59 Land Ct# #SR Life Estate PP STATU Assoc Pid#				Total 722,700 722,700			

801
 FY2024
 BARNSTABLE, MA
VISION

RECORD OF OWNERSHIP		BK-VOL/PAGE		SALE DATE		Q/U		V/I		SALE PRIC		VC		PREVIOUS ASSESSMENTS (HISTORY)			
WOOD, KAREN L		32188	0179	07-30-2019		U	I			0	1	Year	Code	Assessed	Year	Code	Assessed
WOOD, JEANNE ESTATE OF		BA19P09	0	01-08-2018		U	I			0	1F	2023	1010	441,000	2022	1010	380,000
WOOD, JEANNE		10017	0240	01-17-1996		U	I			1	A		1010	207,500		1010	149,300
WOOD, KEITH S & JEANNE		6568	0185	12-23-1988		U	I			1	A					1010	5,400
WOOD, CHRISTOPHER J TR		4615	0039	07-08-1985		Q	V			44,500	U	Total		648,500	Total		529,300
		Total										Total		461,200			

EXEMPTIONS				OTHER ASSESSMENTS			
Year	Code	Description	Amount	Code	Description	Number	Amount
2021	N5C	NO RESIDENTIAL EXEMPTION	0.00				
Total			0.00				

This signature acknowledges a visit by a Data Collector or Assessor

ASSESSING NEIGHBORHOOD			
Nbhd	Nbhd Name	B	Tracing
0106			WBARNS

APPRAISED VALUE SUMMARY			
Appraised Bldg. Value (Card)			454,600
Appraised Xf (B) Value (Bldg)			53,300
Appraised Ob (B) Value (Bldg)			5,400
Appraised Land Value (Bldg)			209,400
Special Land Value			0
Total Appraised Parcel Value			722,700
Valuation Method			C
Total Appraised Parcel Value			722,700

NOTES							

BUILDING PERMIT RECORD										VISIT / CHANGE HISTORY					
Permit Id	Issue Date	Type	Description	Amount	Insp Date	% Comp	Date Comp	Comments		Date	Id	Type	Is	Cd	Purpost/Result
B28694	11-02-1985	DW	Dwelling	90,000	10-15-1986	100		WB 1 STOR		07-29-2021	SR	02		03	Cycl Insp Comp
B28694A	11-01-1985	DW	Dwelling	90,000		100		WB 1 STOR		05-13-2020	DM			FR	Field Review
										11-18-2009	PT	02		14	Cyclical Inspection
										05-03-2000	PT	01		00	Meas/Listed-Interior Acces
										10-15-1986	DH				

LAND LINE VALUATION SECTION																		
B	Use Code	Description	Zone	LA	Land Units	Unit Price	Size Adj	AC Disc	Site Index	Cond.	Nbhd.	Nbhd. Adj	Notes	Location Adjustmen	Adj Unit P	Land Value		
1	1010	Single Fam M-0	RF	5	1.000	AC	176,344.00	1.00000	1.0000	5	1.00	0106	1.150		1.0000	202,795.6	202,800	
1	1010	Single Fam M-0	RF	5	0.400	AC	14,250.00	1.00000	1.0000	0	1.00	0106	1.150		1.0000	16,387.5	6,600	
Total Card Land Units					1.40	AC	Parcel Total Land Area					1.40	Total Land Value					209,400

CONSTRUCTION DETAIL			CONSTRUCTION DETAIL (CONTINUED)		
Element	Cd	Description	Element	Cd	Description
Style	01	Ranch			
Model	01	Residential			
Grade:	C+	Average Plus			
Stories	1	1 Story			
Exterior Wall 1	14	Wood Shingle			
Exterior Wall 2	11	Clapboard			
Roof Structure	03	Gable/Hip			
Roof Cover	03	Asph/F Gls/Cmp			
Interior Wall 1	05	Drywall			
Interior Wall 2					
Interior Floor 1	14	Carpet			
Interior Floor 2	12	Hardwood			
Heat Fuel	02	Oil			
Heat Type	05	Hot Water			
AC Type	03	Central			
Bedrooms	03	3 Bedrooms			
Full Baths	2				
Half Baths	0				
Extra Fixtures					
Total Rooms	6	6 Rooms			
Bath Style					
Kitchen Style					
Occupancy					
Usrflid 105					
Accessory Apt					
Foundation Alt	01	Poured Conc.			
Rms Prts					
Bath Split	20	2 Full-0 Half			

CONDO DATA			
Parcel Id	C	Ownr	0.0
Adjust Type	Code	Description	Factor%
Condo Flr			
Condo Unit			

COST / MARKET VALUATION	
Building Value New	541,178
Year Built	1985
Effective Year Built	1998
Depreciation Code	A
Remodel Rating	
Year Remodeled	
Depreciation %	16
Functional Obsol	0
External Obsol	0
Trend Factor	1
Condition	
Condition %	
Percent Good	84
RCNLD	454,600
Dep % Ovr	
Dep Ovr Comment	
Misc Imp Ovr	
Misc Imp Ovr Comment	
Cost to Cure Ovr	
Cost to Cure Ovr Comment	

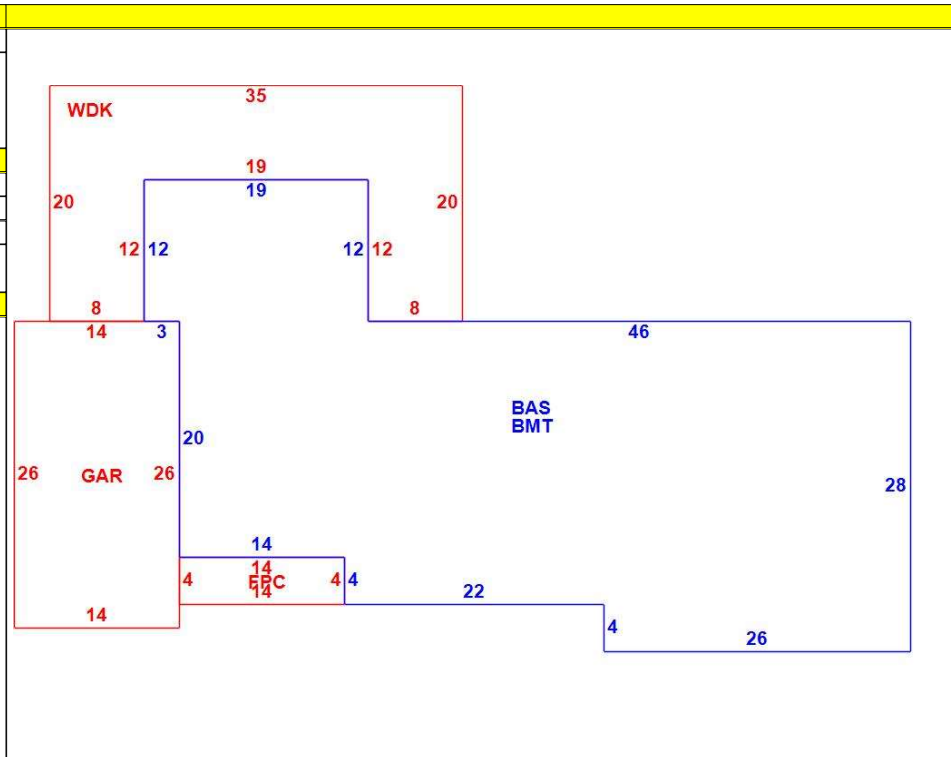

OB - OUTBUILDING & YARD ITEMS(L) / XF - BUILDING EXTRA FEATURES(B)										
Code	Description	L/B	Units	Unit Price	Yr Blt	Cond. Cd	% Gd	Grade	Grade Adj.	Appr. Value
FPL1	Fireplace 1 sto	B	1	5000.00	2000		84		0.00	4,200
WDC	Wood Decking	L	472	20.00	1999		60		0.00	5,400
FOPC	Open Prch-roo	B	56	55.00	2000		84		0.00	2,600
GAR	Attached Gara	B	364	40.00	2000		84		0.00	12,700
BMT	Basement-Unfi	B	1,764	26.01	2000		84		0.00	33,800

BUILDING SUB-AREA SUMMARY SECTION						
Code	Description	Living Area	Floor Area	Eff Area	Unit Cost	Undeprec Value
BAS	First Floor	1,764	1,764	1,764	306.79	541,178
BMT	Basement Area	0	1,764	0	0.00	0
FPC	Open Porch Conc. Floor	0	56	0	0.00	0
GAR	Attached Garage	0	364	0	0.00	0
WDK	Wood Deck	0	472	0	0.00	0
Ttl Gross Liv / Lease Area		1,764	4,420	1,764		541,178

