

CURRENT OWNER		TOPO	UTILITIES	STRT / ROAD	LOCATION	CURRENT ASSESSMENT				801 FY2024 BARNSTABLE, MA  <b>VISION</b>								
FINK, RICHARD J JR & LESLIE B  8 DONNELLY DRIVE  MEDFIELD MA 02052						Description	Code	Assessed	Assessed									
		<b>SUPPLEMENTAL DATA</b>				RESIDNTL	1020	732,200	732,200									
		Alt Prcl ID	Split Zonin	BID Parcel	ResExpt Q	#DL 1	UNIT 5	#DL 2	BLDG D			GIS ID	F_973402_2695169	Plan Ref.	Land Ct# 18162-J LOT 6	#SR	Life Estate	PP STATU
						Total		732,200	732,200									
RECORD OF OWNERSHIP		BK-VOL/PAGE	SALE DATE	Q/U	V/I	SALE PRICE	VC	PREVIOUS ASSESSMENTS (HISTORY)										
FINK, RICHARD J JR & LESLIE B		C278-0	06-02-2021	Q	I	690,000	00	Year	Code	Assessed	Year	Code	Assessed					
SPELLMAN, LAWRENCE J III TR		C278-0	07-29-2005	U	I	100	1A	2023	1020	603,800	2022	1020	333,500					
SPELLMAN, LAWRENCE J III & KERRI ANN		C278-0	12-23-2002	U	I	1	1A				2021	1020	369,800					
SPELLMAN, LAWRENCE J III		C278-0	06-03-2002	Q	I	305,000	00					1020	5,300					
GRADY, KENNETH A TR		C27-0	03-18-2002	U	I	950,000	1	Total		603,800	Total		333,500					
						Total		Total		333,500	Total		375,100					
EXEMPTIONS			OTHER ASSESSMENTS				This signature acknowledges a visit by a Data Collector or Assessor											
Year	Code	Description	Amount	Code	Description	Number	Amount	Comm Int										
		Total	0.00															
ASSESSING NEIGHBORHOOD																		
Nbhd	Nbhd Name	B	Tracing	Batch														
0001				CENVIL														
NOTES																		
BUILDING PERMIT RECORD								VISIT / CHANGE HISTORY										
Permit Id	Issue Date	Type	Description	Amount	Insp Date	% Comp	Date Comp	Comments	Date	Id	Type	Is	Cd	Purpost/Result				
EXPR-22-3 69399	01-11-2022 06-10-2003	835 WD	Sid/Wind/Roof/ Wood Deck	15,000 2,500	06-03-2004	100 100	01-01-2004	Replace doors, windows, and	08-19-2021 07-08-2021 05-18-2020 03-07-2018 09-08-2014 04-26-2013 05-15-2007	BM BM WD KM TP TP JK	03 22 FR 02 03 03 03		16 22 FR 03 16 16 16	In Office Review Change of Address Field Review Cycl Insp Comp In Office Review In Office Review In Office Review				
LAND LINE VALUATION SECTION																		
B	Use Code	Description	Zone	Dist	Land Type	Land Units	Unit Price	Size Adj	Site Index	Cond.	Nbhd.	Nbhd. Adj	Notes	Location Adjustmen	Adj Unit P	Land Value		
1	102U	Condominium M	CBD	3		0 SF	0.00	1.00000	5	1.00	0001	1.000			0.0000	0		
Total Card Land Units						0 SF	Parcel Total Land Area						0.00	Total Land Value				0

CONSTRUCTION DETAIL			CONSTRUCTION DETAIL (CONTINUED)		
Element	Cd	Description	Element	Cd	Description
Style	55	Condominium			
Model	05	Res Condo			
Bedrm Func	C	Average			
Stories	1	1 Story			
Occupancy	0				
Interior Wall 1	05	Drywall			
Interior Wall 2	07	Knotty Pine			
Interior Floor 1	12	Hardwood			
Interior Floor 2					
Heat Fuel	02	Oil			
Heat Type	04	Hot Air			
AC Type	03	Central			
Bedrooms	03	3 Bedrooms			
Full Baths	2	2 Full			
Half Baths	0				
Extra Fixtures					
Total Rooms	5	5 Rooms			
Bath Style					
Kitchen Style					
Master Deed L	1022				
Bath Split	20	2 Full-0 Half			
Foundation	03	Conc. Slab			
AC Type Alt					
Sewer Occupan					
<b>CONDO DATA</b>					
Parcel Id	104206	C 0042	Ownr	16.	
	CORAL VILLAGE		B 1	S 1	
Adjust Type	Code	Description	Factor%		
Condo Flr			100		
Condo Unit	MKT0	MKT0	100		
<b>COST / MARKET VALUATION</b>					
Building Value New		938,945			
Year Built		1950			
Effective Year Built		1989			
Depreciation Code		A			
Remodel Rating					
Year Remodeled		23			
Depreciation %		0			
Functional Obsol		0			
External Obsol		0			
Trend Factor		1			
Condition					
Condition %		77			
Percent Good		77			
Cns Sect Rcnd		723,000			
Dep % Ovr					
Dep Ovr Comment					
Misc Imp Ovr					
Misc Imp Ovr Comment					
Cost to Cure Ovr					
Cost to Cure Ovr Comment					

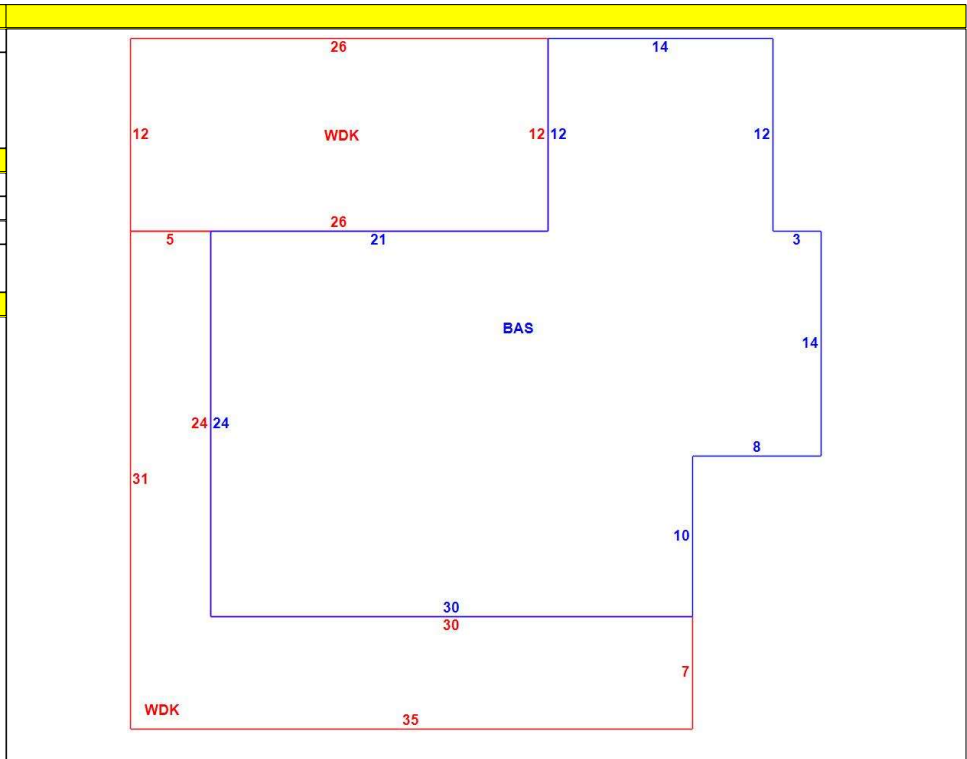

**OB - OUTBUILDING & YARD ITEMS(L) / XF - BUILDING EXTRA FEATURES(B)**

Code	Description	L/B	Units	Unit Price	Yr Blt	Cond. Cd	% Gd	Grade	Grade Adj.	Appr. Value
FPL1	Fireplace 1 sto	B	1	5000.00	1990		77		0.00	3,900
WDC	Wood Decking	L	312	20.00	1990		42		0.00	2,600
WDC	Wood Deck w/	L	365	18.00	1990		42		0.00	2,700

<b>BUILDING SUB-AREA SUMMARY SECTION</b>										
Code	Description	Living Area	Floor Area	Eff Area	Unit Cost	Undeprec Value				
BAS	First Floor	1,000	1,000	1,000	938.94	938,945				
WDK	Wood Deck	0	677	0	0.00	0				
Ttl Gross Liv / Lease Area		1,000	1,677	1,000		938,945				

