

CONSTRUCTION DETAIL			CONSTRUCTION DETAIL (CONTINUED)		
Element	Cd	Description	Element	Cd	Description
Style	55	Condominium			
Model	05	Res Condo			
Bedrm Func	C	Average			
Stories	1	1 Story			
Occupancy	0				
Interior Wall 1	05	Drywall			
Interior Wall 2					
Interior Floor 1	20	Typical			
Interior Floor 2					
Heat Fuel	03	Gas			
Heat Type	04	Hot Air			
AC Type	03	Central			
Bedrooms	01	1 Bedroom			
Full Baths	2	2 Full			
Half Baths	0				
Extra Fixtures					
Total Rooms	2				
Bath Style					
Kitchen Style					
Master Deed L	392				
Bath Split	20	2 Full-0 Half			
Foundation	09	Blk/Pour Ftgs			
AC Type Alt					
Sewer Occupan					
CONDO DATA					
Parcel Id	104239	C 0242	Ownr	9.4	
	SUNI SANDS	B 1	S 1		
Adjust Type	Code	Description	Factor%		
Condo Flr			100		
Condo Unit	MKT0	MKT0	100		
COST / MARKET VALUATION					
Building Value New		321,585			
Year Built		1950			
Effective Year Built		1994			
Depreciation Code		G			
Remodel Rating					
Year Remodeled		19			
Depreciation %		0			
Functional Obsol		0			
External Obsol		0			
Trend Factor		1			
Condition					
Condition %		81			
Percent Good		260,500			
Cns Sect Rcnld					
Dep % Ovr					
Dep Ovr Comment					
Misc Imp Ovr					
Misc Imp Ovr Comment					
Cost to Cure Ovr					
Cost to Cure Ovr Comment					

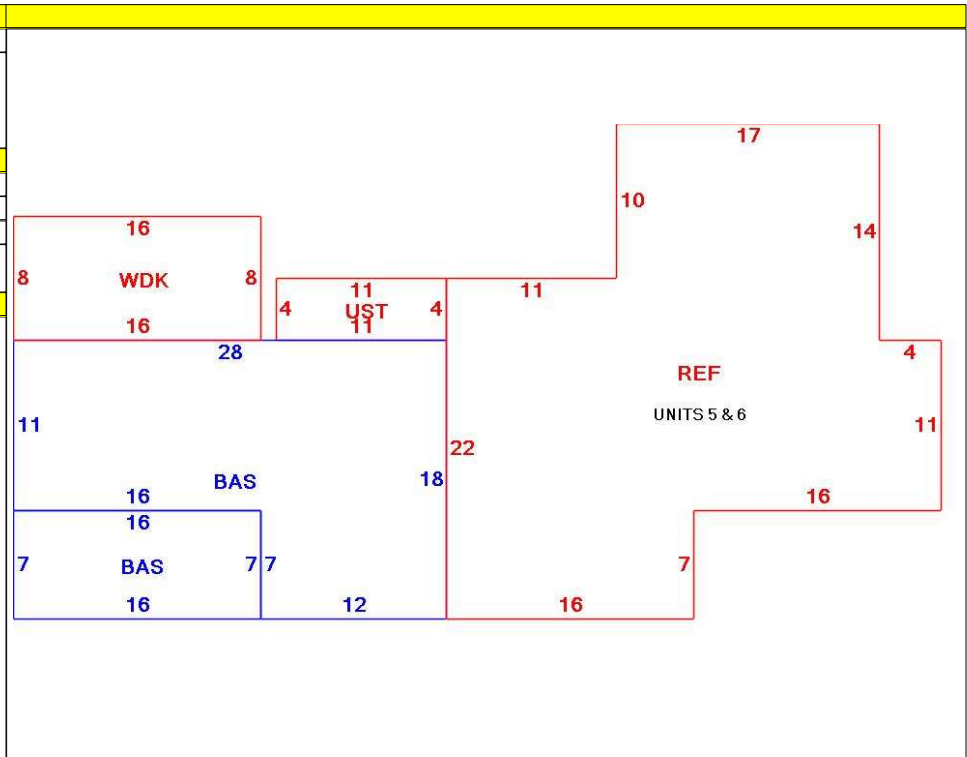

OB - OUTBUILDING & YARD ITEMS(L) / XF - BUILDING EXTRA FEATURES(B)										
Code	Description	L/B	Units	Unit Price	Yr Blt	Cond. Cd	% Gd	Grade	Grade Adj.	Appr. Value
WDC	Wood Decking	L	128	20.00	1990		42		0.00	1,600
UST	Utility Storage	B	44	17.11	1995		81		0.00	600

BUILDING SUB-AREA SUMMARY SECTION							
Code	Description	Living Area	Floor Area	Eff Area	Unit Cost	Undeprec Value	
BAS	First Floor	504	504	504	638.07	321,585	
REF	Reference Only	0	746	0	0.00	0	
UST	Utility Enclosure	0	44	0	0.00	0	
WDK	Wood Deck	0	128	0	0.00	0	
Ttl Gross Liv / Lease Area		504	1,422	504		321,585	

