

CURRENT OWNER				TOPO	UTILITIES	STRT / ROAD	LOCATION	CURRENT ASSESSMENT				
HEIM, SCOTT J & JENNIFER WEAVE								Description	Code	Assessed	Assessed	801 FY2024 BARNSTABLE, MA
79 GLENVIEW STREET								RESIDNTL	1020	355,400	355,400	
UPTON MA 01568												
SUPPLEMENTAL DATA												
Alt Prcl ID						Plan Ref. 353/81-82						
Split Zonin						Land Ct#						
BID Parcel						#SR						
ResExpt Q						Life Estate						
#DL 1						PP STATU						
#DL 2						BLDG E						
GIS ID F_973712_2695450						Assoc Pid#						
									Total	355,400	355,400	

RECORD OF OWNERSHIP							BK-VOL/PAGE	SALE DATE	Q/U	V/I	SALE PRICE	VC	PREVIOUS ASSESSMENTS (HISTORY)									
HEIM, SCOTT J & JENNIFER WEAVER							25107	0124	12-20-2010	Q	I	290,000	00	Year	Code	Assessed	Year	Code	Assessed	Year	Code	Assessed
DARIGAN, JOHN T & ALLISON M							19738	0304	04-20-2005	Q	I	350,000	00	2023	1020	294,400	2022	1020	245,300	2021	1020	238,100
AUCOIN, PETER & ELIZABETH							3511	0292	07-15-1982	Q	I	36,000	U								1020	7,200
													Total	294,400	Total	245,300	Total	245,300				

EXEMPTIONS				OTHER ASSESSMENTS				This signature acknowledges a visit by a Data Collector or Assessor													
Year	Code	Description	Amount	Code	Description	Number	Amount	Comm Int													
			Total	0.00																	
ASSESSING NEIGHBORHOOD								APPRAISED VALUE SUMMARY													
Nbhd		Nbhd Name		B		Tracing		Batch		Appraised Bldg. Value (Card)					343,600						
0001								CENVIL		Appraised Xf (B) Value (Bldg)					4,600						
										Appraised Ob (B) Value (Bldg)					7,200						
										Appraised Land Value (Bldg)					0						
										Special Land Value					0						
										Total Appraised Parcel Value					355,400						
										Valuation Method					C						
										Total Appraised Parcel Value					355,400						

BUILDING PERMIT RECORD								VISIT / CHANGE HISTORY							
Permit Id	Issue Date	Type	Description	Amount	Insp Date	% Comp	Date Comp	Comments	Date	Id	Type	Is	Cd	Purpost/Result	
71130	08-29-2003	RW	Repair Work	2,000	06-03-2004	100	01-01-2004		05-18-2020	WD			FR	Field Review	
B35196	07-01-1992	AD	Addition	6,000	01-15-1993	100		CE SUN RM	03-07-2018	KM	02		03	Cycl Insp Comp	
									12-28-2010	DR	22		22	Change of Address	
									03-19-2008	JR	03		16	In Office Review	
									11-08-2007	MA	22		22	Change of Address	
									01-09-2006	PT	02		01	Meas/Est	
									06-03-2004	MF	02		02	Bldg Permit Completed	

LAND LINE VALUATION SECTION																			
B	Use Code	Description	Zone	Dist	Land Type	Land Units	Unit Price	Size Adj	Site Index	Cond.	Nbhd.	Nbhd. Adj	Notes	Location Adjustmen	Adj Unit P	Land Value			
1	102U	Condominium M	CBD	3		0 SF	0.00	1.00000	5	1.00	0001	1.000		0.0000	0	0			
Total Card Land Units						0	SF	Parcel Total Land Area						0.00	Total Land Value				0

**VISION**

CONSTRUCTION DETAIL			CONSTRUCTION DETAIL (CONTINUED)		
Element	Cd	Description	Element	Cd	Description
Style	55	Condominium			
Model	05	Res Condo			
Bedrm Func	C	Average			
Stories	1	1 Story			
Occupancy	0				
Interior Wall 1	07	Knotty Pine			
Interior Wall 2					
Interior Floor 1	14	Carpet			
Interior Floor 2					
Heat Fuel	04	Electric			
Heat Type	07	Elec Baseboard			
AC Type	01	None			
Bedrooms	02	2 Bedrooms			
Full Baths	1	1 Full			
Half Baths	0				
Extra Fixtures					
Total Rooms	5	5 Rooms			
Bath Style					
Kitchen Style					
Master Deed L	768				
Bath Split	10	1 Full-0 Half			
Foundation	09	Blk/Pour Ftgs			
AC Type Alt					
Sewer Occupan					
CONDO DATA					
Parcel Id	104239	C 0242	Ownr	10.	
	SUNI SANDS		B 1	S 1	
Adjust Type	Code	Description	Factor%		
Condo Flr			100		
Condo Unit	MKT0	MKT0	100		
COST / MARKET VALUATION					
Building Value New			424,244		
Year Built			1950		
Effective Year Built			1994		
Depreciation Code			G		
Remodel Rating					
Year Remodeled			19		
Depreciation %			0		
Functional Obsol			0		
External Obsol			0		
Trend Factor			1		
Condition					
Condition %			81		
Percent Good					
Cns Sect Rcnld			343,600		
Dep % Ovr					
Dep Ovr Comment					
Misc Imp Ovr					
Misc Imp Ovr Comment					
Cost to Cure Ovr					
Cost to Cure Ovr Comment					

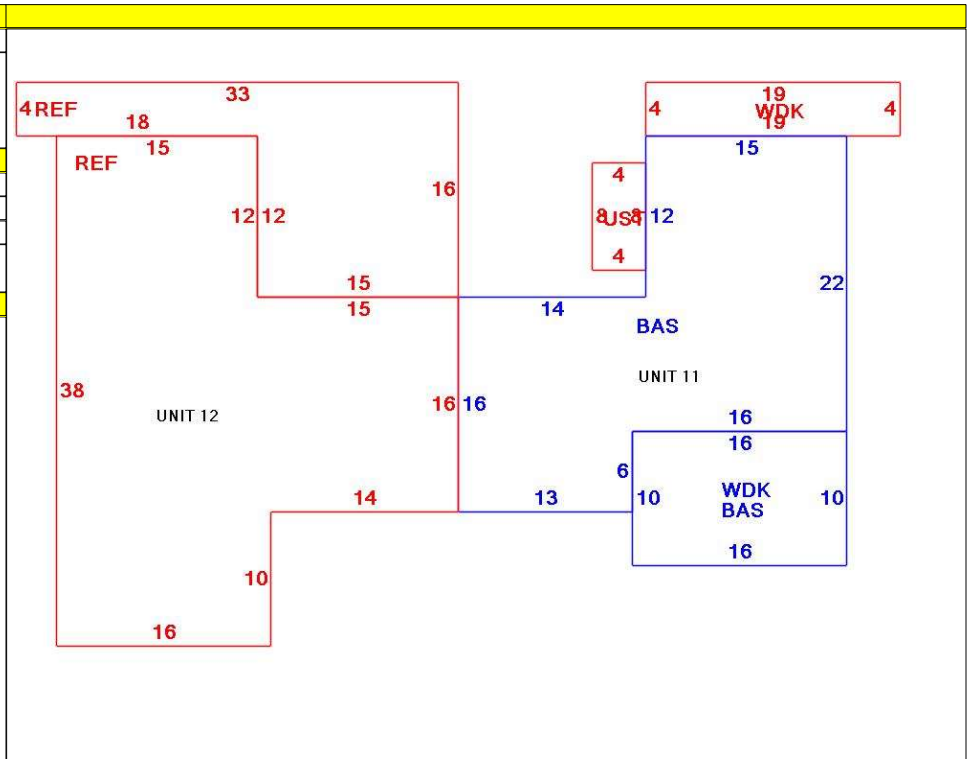

OB - OUTBUILDING & YARD ITEMS(L) / XF - BUILDING EXTRA FEATURES(B)										
Code	Description	L/B	Units	Unit Price	Yr Blt	Cond. Cd	% Gd	Grade	Grade Adj.	Appr. Value
FPL1	Fireplace 1 sto	B	1	5000.00	1995		81		0.00	4,100
WDC	Deck comp w	L	236	28.00	2018		99		0.00	7,200
UST	Utility Storage-	B	32	17.11	1995		81		0.00	500

BUILDING SUB-AREA SUMMARY SECTION						
Code	Description	Living Area	Floor Area	Eff Area	Unit Cost	Undeprec Value
BAS	First Floor	708	708	708	599.21	424,244
REF	Reference Only	0	1,132	0	0.00	0
UST	Utility Enclosure	0	32	0	0.00	0
WDK	Wood Deck	0	236	0	0.00	0
Ttl Gross Liv / Lease Area		708	2,108	708		424,244

